



Hand in hand for tomorrow



Product data sheet

Manual change system CMS

CMS

Manual change system

Flexible. Compact. Intuitive. Manual change system CMS

User-friendly manual change system with extensive complementary portfolio

Field of application

Ideally suited for use in the flexible production and assembly of products with a comprehensive range of variants in which reliable manual changes are required. The system is suitable for use on robots as well as for stationary applications.

Advantages – Your benefits

Series with six unit sizes for optimal size selection and a broad application range

ISO mounting pattern for easy assembly to most types of robots without needing additional adapter plates

Wide range of signal, pneumatic, fluid and communication modules can be screwed on directly for universal energy transmission options

Optional locking and presence monitoring integrated in the housing for all sizes

Integrated air feed-throughs for a reliable power supply of the handling modules and tools with pneumatic and vacuum, can be used radially and axially

Basic version without integrated air feed-through and sensor option available for simple and cost-sensitive applications



Sizes
Quantity: 6



Handling weight
9 .. 58 kg



Moment load Mx
22.5 .. 478 Nm



Moment load Mz
15 .. 465 Nm

Functional description

The manual change system (CMS) consists of a change head (CMS-K) and a change adapter (CMS-A). Closing the hand lever provides a form-fit lock that is free from play between the change head and the change adapter using a pin and without the need for any additional tools. Opening the hand lever unlocks the system, allowing the change adapter to be removed. End effectors can be

supplied with compressed air or vacuum via integrated pneumatic feed-throughs. In addition, there is an identically constructed variant without pneumatic feed-throughs and without a monitoring option (CMS-B). In both product variants, the tool can be supplied with other media such as electrical signals or fluids through optional modules.

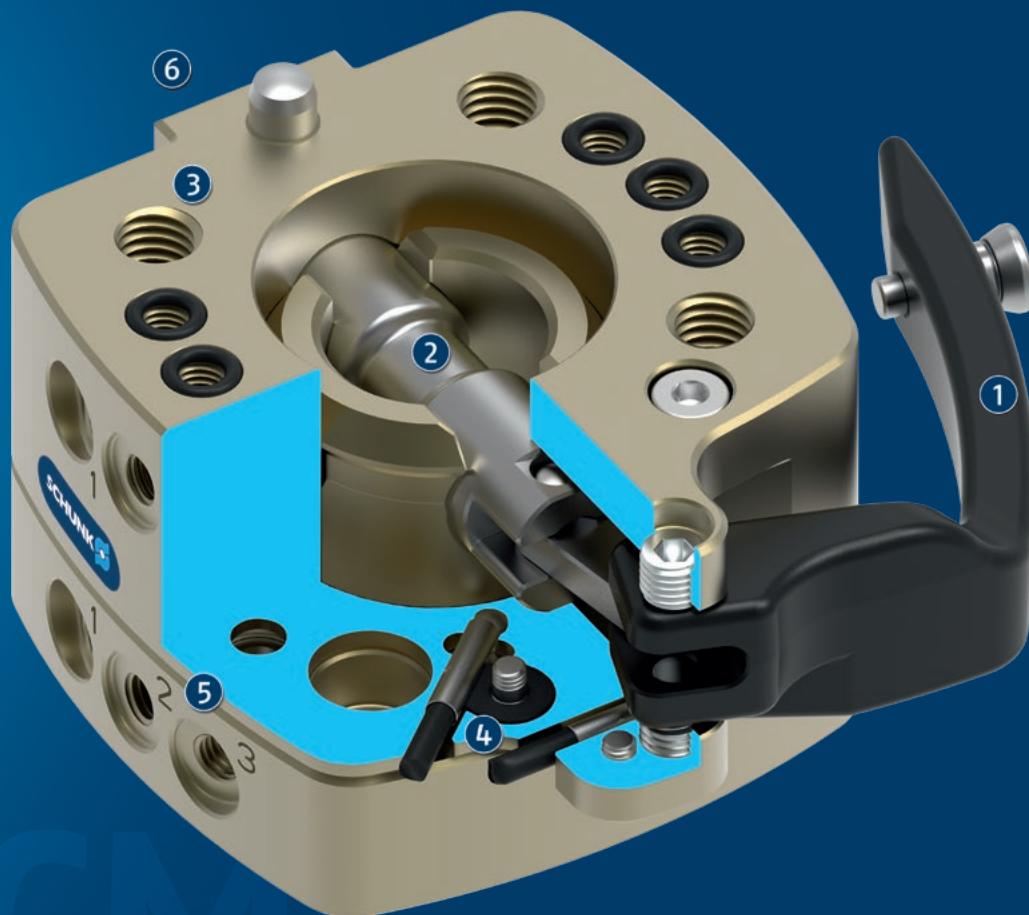

- ① **Locking lever**
Proven technology for manual actuation without additional tools
- ② **Locking pin**
made of corrosion-free steel for easy and secure locking
- ③ **ISO mounting pattern**
Master and adapter side, for easy assembly to most types of robots without needing additional adapter plates
- ④ **Integrated locking and tool presence monitoring**
optional, for process-reliable monitoring of the locking condition and tool presence
- ⑤ **Integrated air feed-through**
all can be used radially and axially for pneumatics and vacuum.
- ⑥ **Standardized screw-on surface for direct attachment of electrical, pneumatic and fluid modules**
Enables versatile energy transmission for controlling a wide range of tools

General notes about the series

Actuation: Manual via locking lever

Operating principle: The head and adapter are locked and unlocked with a pin by operating the manual lever.

Housing: The housing consists of high-strength, hard-coated aluminum alloy. The functional components are made of hardened steel.

Warranty: 24 months

Harsh environmental conditions: Please note that use under harsh environmental conditions (e.g. in the coolant area, cast and grinding dust) can considerably reduce the service life of the units, and we will not take over any warranty. However, in many cases we can find a solution. Please contact us for assistance.

Handling weight: is the weight of the total load attached to the flange. When designing, the permissible forces and moments have to be paid attention to. Please note that exceeding the recommended handling weight will shorten the lifespan.

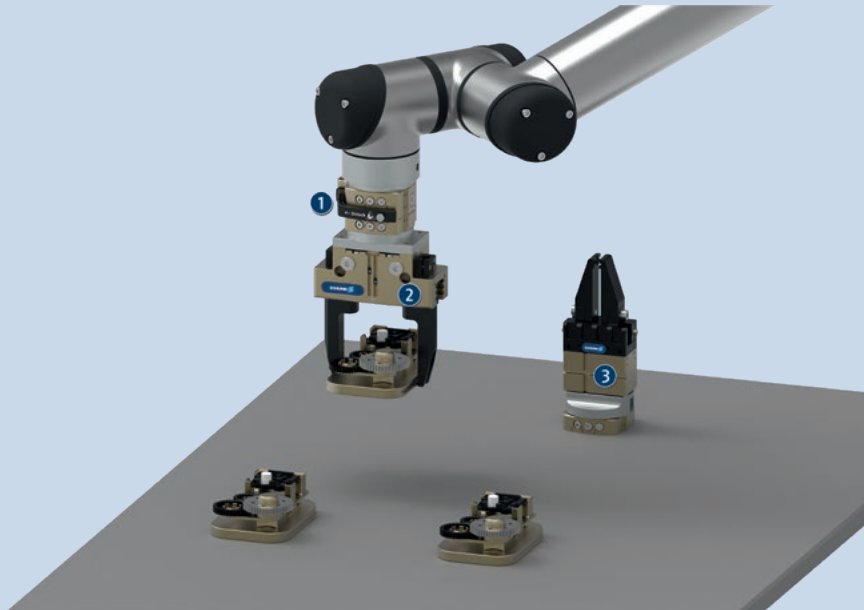

Application example

Tool for handling and assembling small to medium-sized workpieces, consisting of manual change system and gripper.

- 1 Manual change system CMS
- 2 2-finger parallel gripper PGN-plus-P with customized gripper fingers
- 3 2-finger parallel gripper MPG-plus with customized gripper fingers

SCHUNK offers more ...

The following components make the product even more productive – the suitable addition for the highest functionality, flexibility, reliability, and controlled production.



Rotary feed-through



Compensation unit



Anti-collision and overload protection sensor

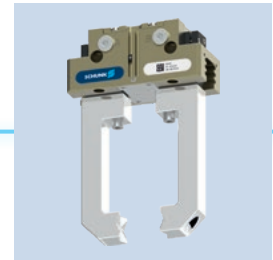

Universal gripper



Inductive proximity switch



Optional modules COS

① For more information on these products can be found on the following product pages or at [schunk.com](https://www.schunk.com).

Options and special information

Basic version: simplified version without integrated air ducts and without monitoring options for maximum economy.

SHA version (-N): with the same tool-sided screw connection diagram as the predecessor product SHA. Allows simple replacement of existing SHS systems with the CMS without changing the customer-specific tools. The SHA version differs from the basic design only on the adapter side (CMS-A).

Food-grade lubrication: The product contains food-compliant lubricants as standard. The requirements of EN 1672-2:2020 are not fully met. The relevant NSF certificates are available at <https://info.nsf.org/USDA/Listings.asp> using the lubricant information in the operating manual.

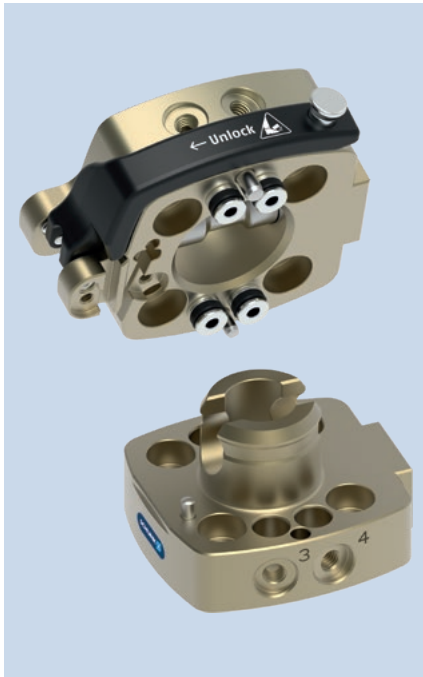

Load diagram

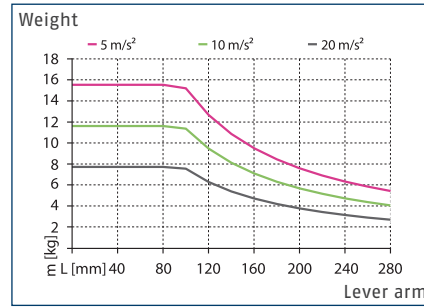

Maximum handling weight as a function of acceleration and lever arm (by M_x/M_y). The diagram does not replace the technical design.

Dimensions and maximum loads

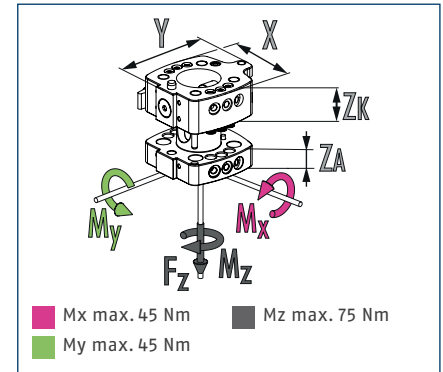

ⓘ This is the sum of all static loads that are permitted to act on the change system to ensure error-free functioning.

Technical data

Description		CMS 040-K	CMS 040-A
		Manual change head	Manual change adapter
ID		1545243	1545265
Recommended handling weight	[kg]	9	9
Lock sensing		optional	
Tool presence monitoring		optional	
Repeat accuracy	[mm]	0.02	0.02
Weight	[kg]	0.16	0.09
Number of pneumatic feed-throughs		4	4
Feed-throughs for radial use		4	4
Air connection thread pneumatic feed-through (radial)		M5	M5
Robot-side coupling flange		ISO 9409-1-40-4-M6	
Coupling flange, tool side			ISO 9409-1-40-4-M6
Dimensions X x Y x Z*	[mm]	50/67.5/24	50/55/15
Min./max. ambient temperature	[°C]	5/60	5/60
Dimensions \varnothing D x Z*	[mm]		- x 15
Screw connection diagram		S7	S7
max. static tensile force F_z	[N]	700	700
Max. dynamic moment M_x/M_y	[Nm]	22.5	22.5
Max. dynamic moment M_z	[Nm]	15	15
Options and their characteristics			
Basic version		CMS 040-K-B	CMS 040-A-B
ID		1545285	1545287
Lock sensing		not possible	
Weight	[kg]	0.16	0.09
SHA version (-N)			CMS 040-A-N
ID			1545281
Weight	[kg]		0.09
Tool-side connection			\varnothing 40, 4xM8

* *Please note that the heights of the change master (ZK) and change adapter (ZA) differ. The sum represents the total height of a coupled change system.

Main view

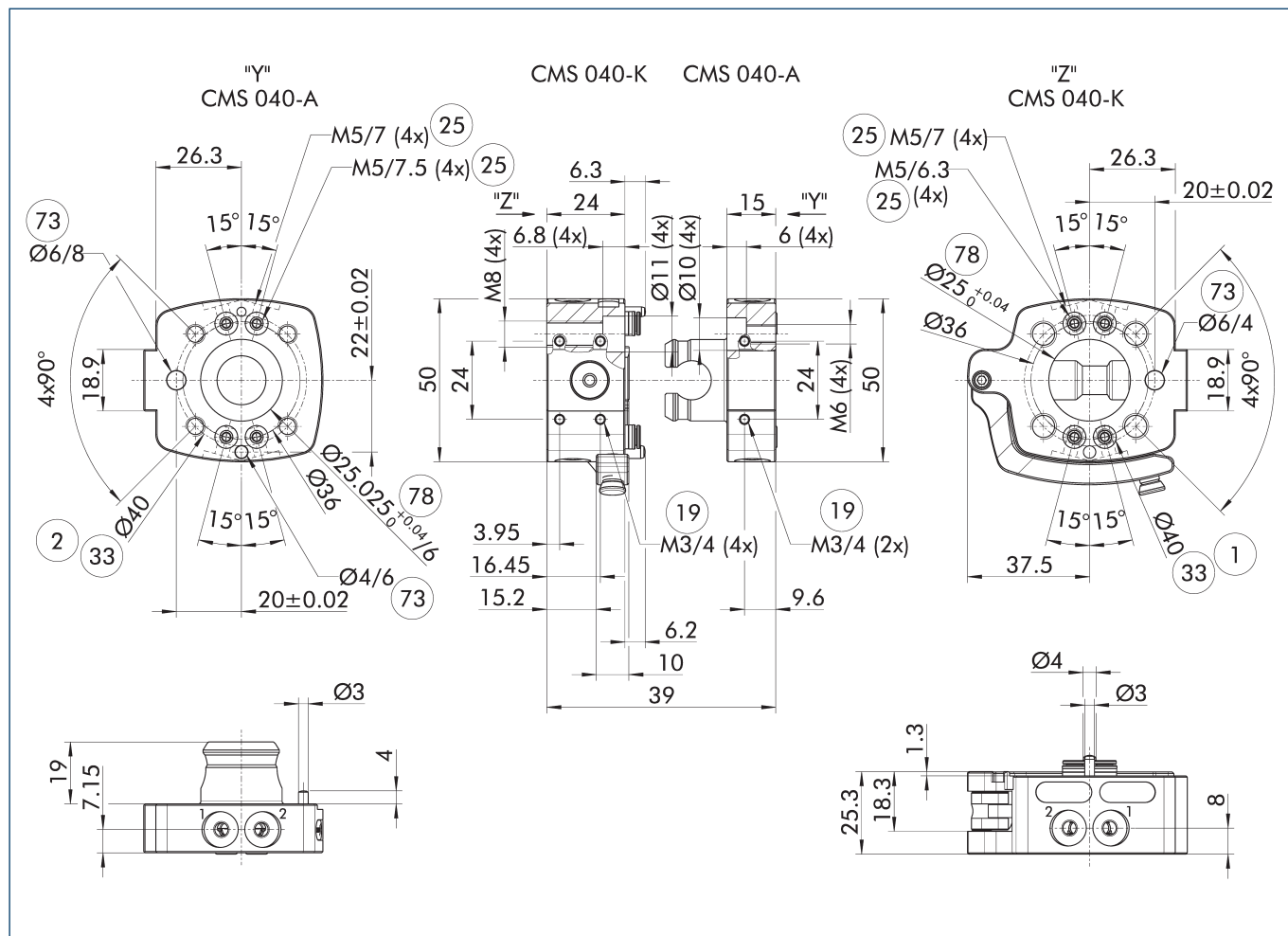

The main view shows the unit in its basic version.

- ① Robot-side connection
- ② Tool-side connection
- ③ DIN ISO-9409 bolt circle
- ④ Fit for centering pins
- ⑤ Mounting surface for options
- ⑥ Fit for centering
- ⑦ Pneumatic feed-throughs

Interference Contour when locking/unlocking

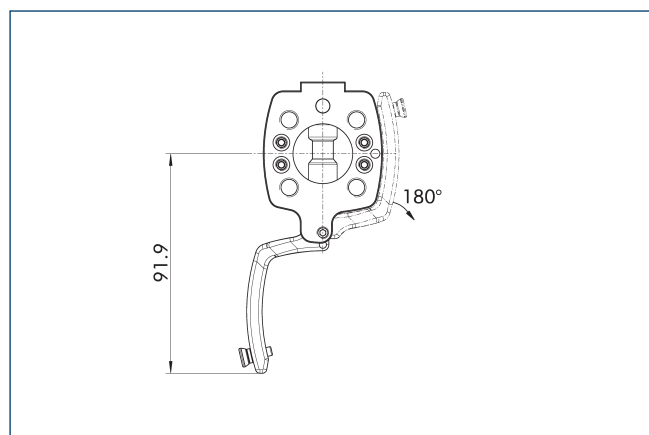

The drawing shows the interfering contour when locking and unlocking. The specified values may vary depending on the opening angle of the locking lever.

Basic version (-B)

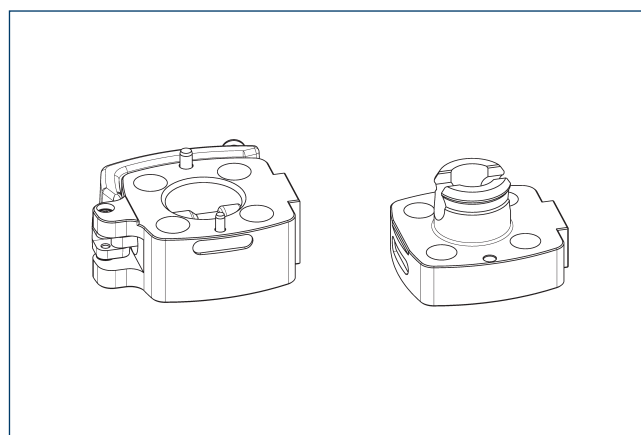

The basic version is a simplified basic design variant without integrated air feed-throughs and without monitoring options.

SHA version (-N)

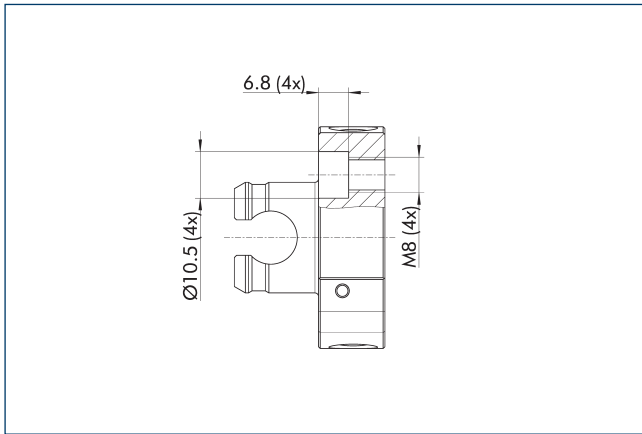

The SHA version has the same screw-on pattern on the tool side as the predecessor product SHS. Thus, existing SHS systems can be replaced by the CMS without changing the tools.

Pneumatic feed-through

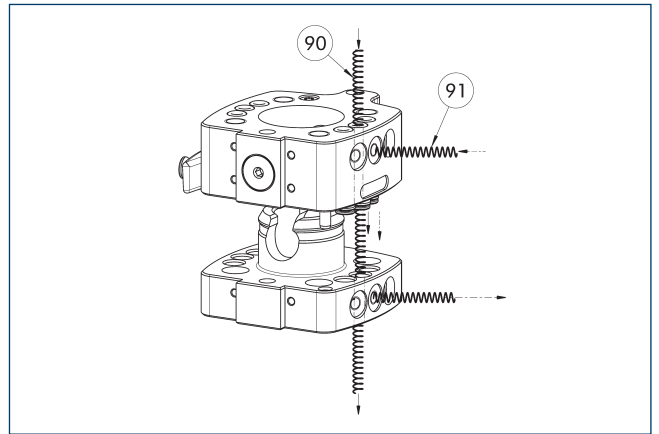

- 90 Feed-through axial
- 91 Feed-through radial

The change system features feed-throughs for pneumatics or vacuum integrated in the housing. They can be used hose-free via an adapter plate (axial) or with a hose (radial).

Electric feed-through module

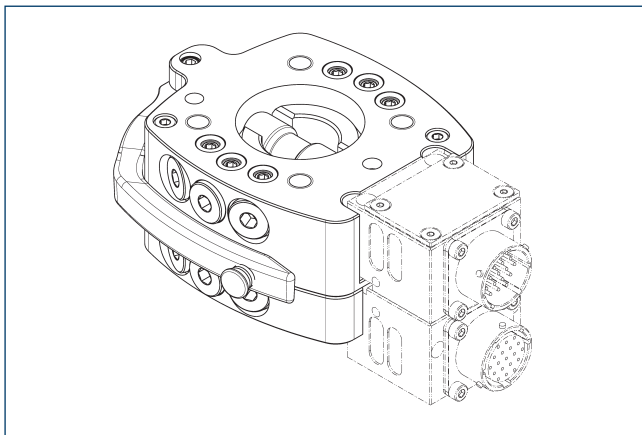

For detailed information, see the "COS" chapter in the catalog, or visit schunk.com.

Adapter plate ISO-31,5

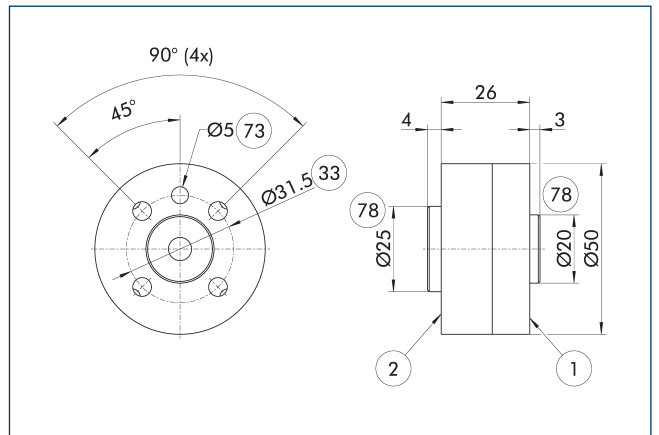

- 1 Robot-side connection
- 2 Tool-side connection
- 33 DIN ISO-9409 bolt circle
- 73 Fit for centering pins
- 78 Fit for centering

Robot side adapter plate

Description	ID
Adapter plate	
AKO ISO31,5/CMS040K	1644713

Centering collar on CMS-K

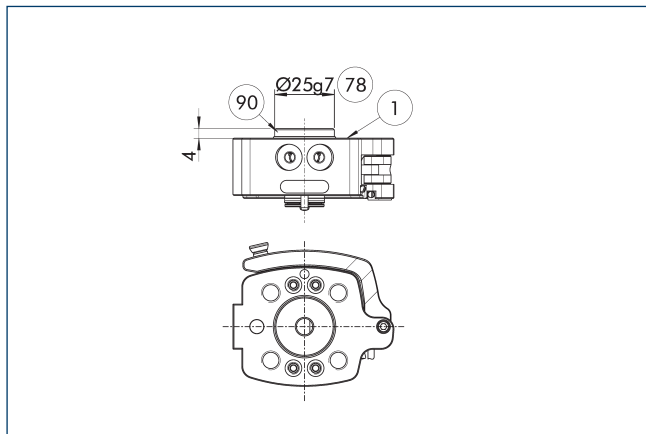

- ① Robot-side connection
- ⑨0 Centring disc
- ⑦8 Fit for centering

Description	ID
Centering disc	
ZB-CMS-040-K CENTERING COLLAR	1574471

① Serves as a fitting collar for centering on mechanical interfaces, e. g. on the robot.

Cable connector

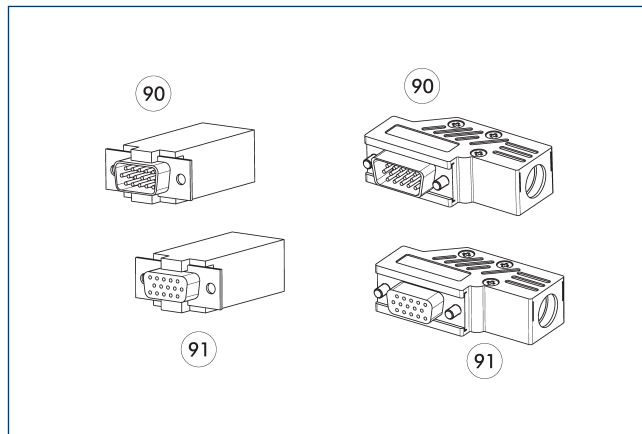

- ⑨0 D-sub connecting plug
- ⑨1 D-sub connector

Description	ID	Note
Angled cable connector, robot-side		
KBU-DA-W 15P	0301301	D-Sub, 15 pins, socket, angled
Angled cable connector, tool-side		
KST-DA-W 15P	0301302	D-Sub, 15 pins, plug, angled
Straight cable connector, robot-side		
KBU-DA-G 15P	0301264	D-Sub, 15 pins, socket, straight
Straight cable connector, tool-side		
KST-DA-G 15P	0301265	D-Sub, 15 pins, plug, straight
Cable extension		
KA BG08-L 8AP-0500	0302180	
KA BW08-L 8AP-0500	0302182	
KA SG08-L 8AP-0200	0302181	
KA SW08-L 8AP-0200	0302183	

④ Detailed information and further cable connectors can be found at schunk.com

Monitoring via inductive proximity switches

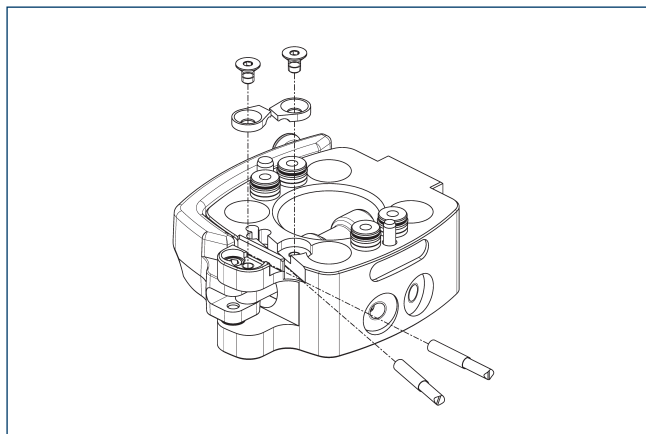

The CMS-K is prepared for locking monitoring as well as tool presence. One attachment kit each is required for this. Each attachment kit includes one sensor and one bracket incl. a screw.

Description	ID
Robot side	
AS-CMS-K-IN30K	1548743

④ This attachment kit is optional and must be ordered separately as an accessory.



Load diagram

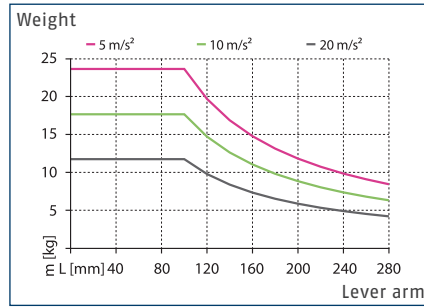

Maximum handling weight as a function of acceleration and lever arm (by M_x/M_y). The diagram does not replace the technical design.

Dimensions and maximum loads

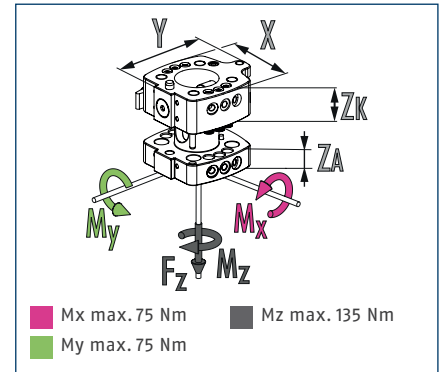

ⓘ This is the sum of all static loads that are permitted to act on the change system to ensure error-free functioning.

Technical data

Description		CMS 050-K	CMS 050-A
		Manual change head	Manual change adapter
ID		1545289	1545310
Recommended handling weight	[kg]	11	11
Lock sensing		optional	
Tool presence monitoring		optional	
Repeat accuracy	[mm]	0.02	0.02
Weight	[kg]	0.27	0.14
Number of pneumatic feed-throughs		6	6
Feed-throughs for radial use		6	6
Air connection thread pneumatic feed-through (radial)		M5	M5
Robot-side coupling flange		ISO 9409-1-50-4-M6	
Coupling flange, tool side			ISO 9409-1-50-4-M6
Dimensions X x Y x Z*	[mm]	63/75.5/26.5	63/63/16
Min./max. ambient temperature	[°C]	5/60	5/60
Dimensions \varnothing D x Z*	[mm]		- x 16
Screw connection diagram		S7	S7
max. static tensile force F_z	[N]	900	900
Max. dynamic moment M_x/M_y	[Nm]	35	35
Max. dynamic moment M_z	[Nm]	27	27
Options and their characteristics			
Basic version		CMS 050-K-B	CMS 050-A-B
ID		1545314	1545315
Lock sensing		not possible	
Weight	[kg]	0.27	0.15
SHA version (-N)			CMS 050-A-N
ID			1545313
Weight	[kg]		0.14
Tool-side connection			\varnothing 50, 4xM8

* *Please note that the heights of the change master (ZK) and change adapter (ZA) differ. The sum represents the total height of a coupled change system.

Main view

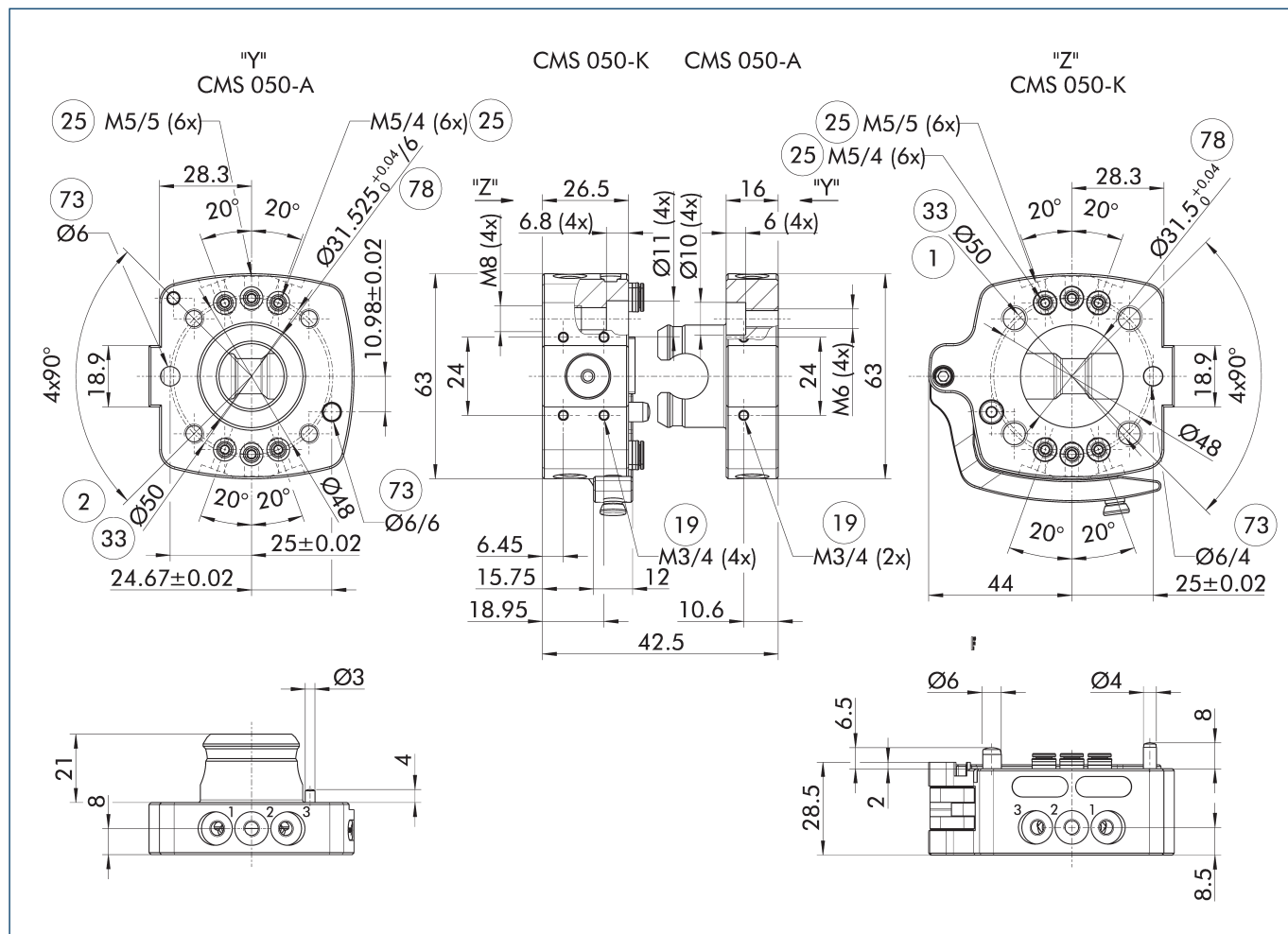

The main view shows the unit in its basic version.

- ① Robot-side connection
- ② Tool-side connection
- ⑱ Mounting surface for options
- ⑳ Pneumatic feed-throughs
- ③③ DIN ISO-9409 bolt circle
- ⑦③ Fit for centering pins
- ⑦⑧ Fit for centering

Interference Contour when locking/unlocking

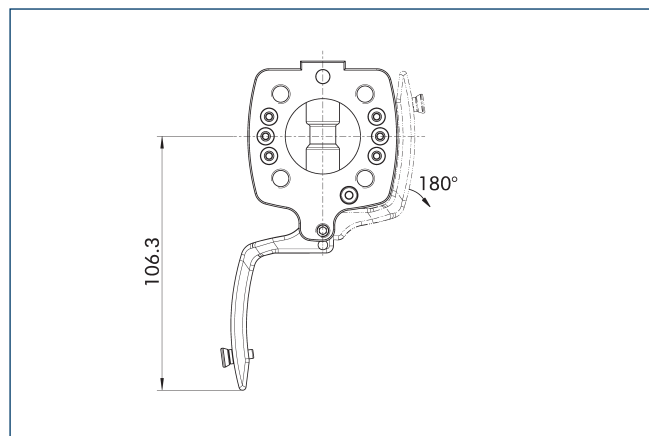

The drawing shows the interfering contour when locking and unlocking. The specified values may vary depending on the opening angle of the locking lever.

Basic version (-B)

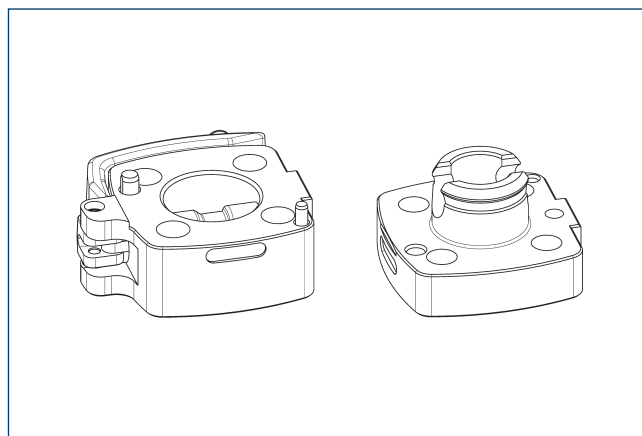

The basic version is a simplified basic design variant without integrated air feed-throughs and without monitoring options.

CMS 050

Manual change system

SHA version (-N)

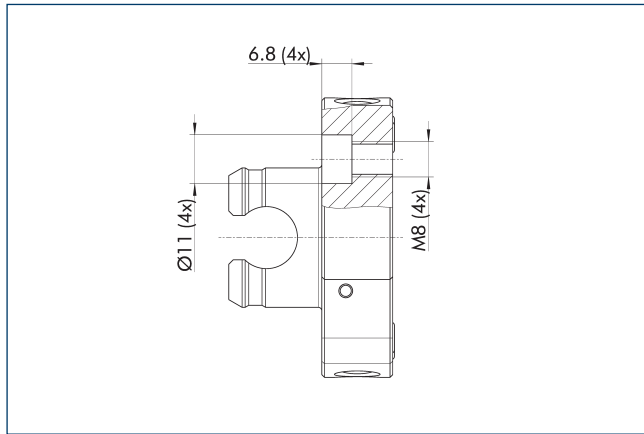

The SHA version has the same screw-on pattern on the tool side as the predecessor product SHS. Thus, existing SHS systems can be replaced by the CMS without changing the tools.

Pneumatic feed-through

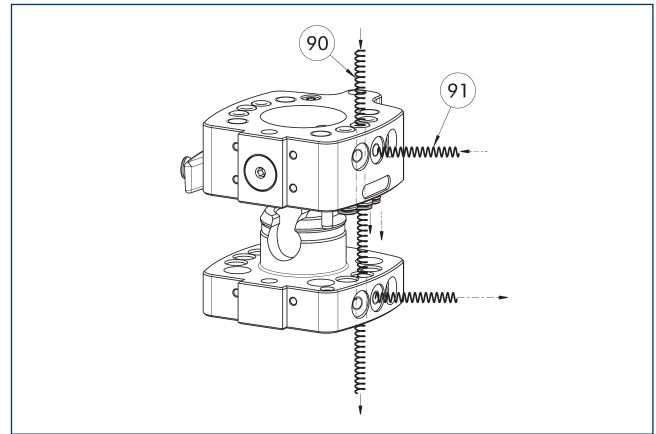

- 90 Feed-through axial
- 91 Feed-through radial

The change system features feed-throughs for pneumatics or vacuum integrated in the housing. They can be used hose-free via an adapter plate (axial) or with a hose (radial).

Electric feed-through module

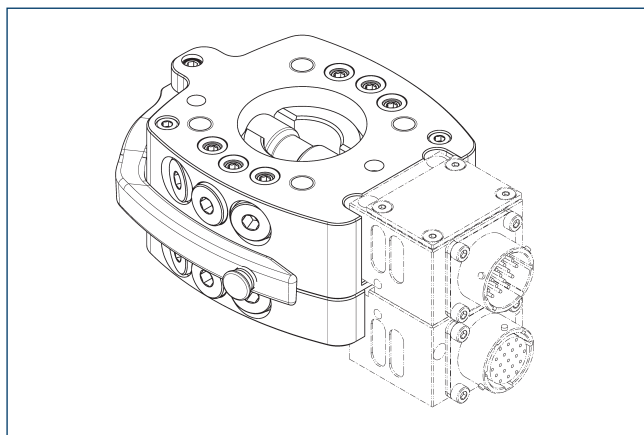

For detailed information, see the "COS" chapter in the catalog, or visit schunk.com.

Centering collar on CMS-K

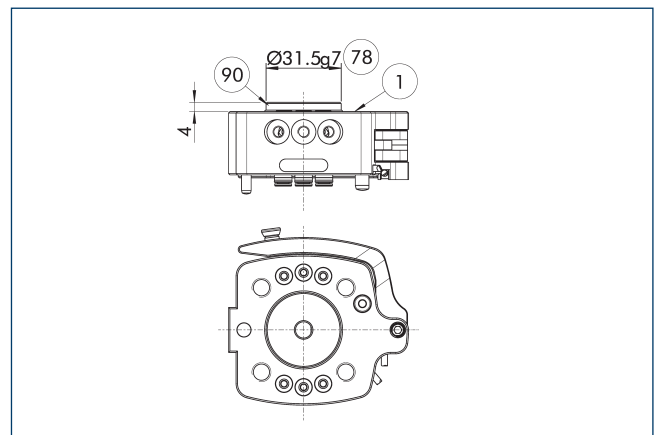

- 1 Robot-side connection
- 78 Fit for centering
- 90 Centring disc

Description	ID
Centering disc	
ZB-CMS-050-K CENTERING COLLAR	1574472

Serves as a fitting collar for centering on mechanical interfaces, e. g. on the robot.

Cable connector

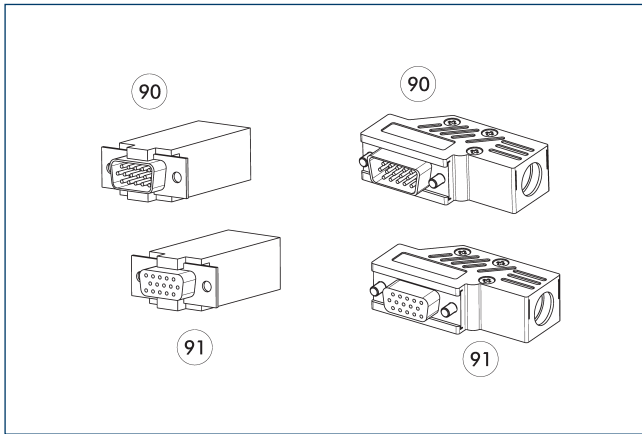

90 D-sub connecting plug

91 D-sub connector

Description	ID	Note
Angled cable connector, robot-side		
KBU-DA-W 15P	0301301	D-Sub, 15 pins, socket, angled
Angled cable connector, tool-side		
KST-DA-W 15P	0301302	D-Sub, 15 pins, plug, angled
Straight cable connector, robot-side		
KBU-DA-G 15P	0301264	D-Sub, 15 pins, socket, straight
Straight cable connector, tool-side		
KST-DA-G 15P	0301265	D-Sub, 15 pins, plug, straight
Cable extension		
KA BG08-L 8AP-0500	0302180	
KA BW08-L 8AP-0500	0302182	
KA SG08-L 8AP-0200	0302181	
KA SW08-L 8AP-0200	0302183	

① Detailed information and further cable connectors can be found at schunk.com

Monitoring via inductive proximity switches

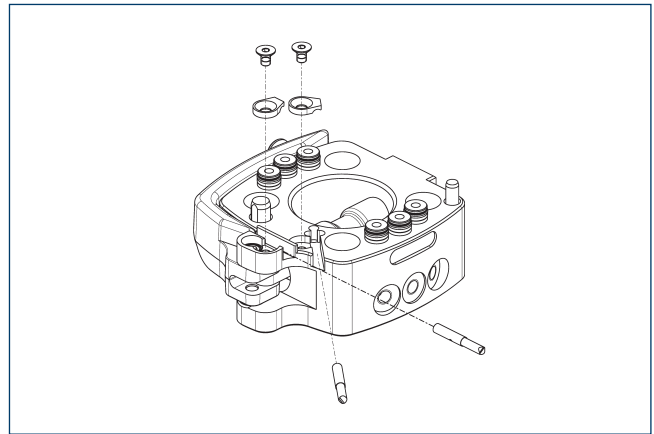

The CMS-K is prepared for locking monitoring as well as tool presence. One attachment kit each is required for this. Each attachment kit includes one sensor and one bracket incl. a screw.

Description	ID	
Robot side		
AS-CMS-K-IN30K	1548743	

① This attachment kit is optional and must be ordered separately as an accessory.



Load diagram

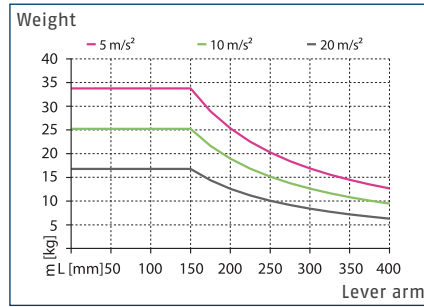

Maximum handling weight as a function of acceleration and lever arm (by M_x/M_y). The diagram does not replace the technical design.

Dimensions and maximum loads

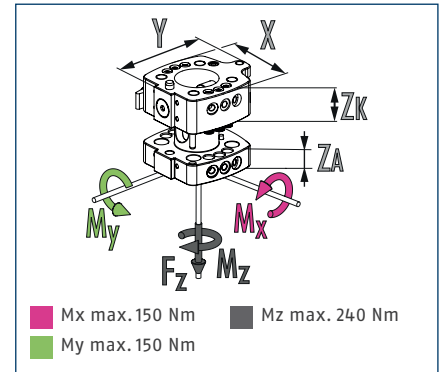

ⓘ This is the sum of all static loads that are permitted to act on the change system to ensure error-free functioning.

Technical data

Description		CMS 063-K	CMS 063-A
		Manual change head	Manual change adapter
ID		1545316	1545318
Recommended handling weight	[kg]	18	18
Lock sensing		optional	
Tool presence monitoring		optional	
Repeat accuracy	[mm]	0.02	0.02
Weight	[kg]	0.49	0.27
Number of pneumatic feed-throughs		6	6
Feed-throughs for radial use		6	6
Air connection thread pneumatic feed-through (radial)		G1/8"	G1/8"
Robot-side coupling flange		ISO 9409-1-63-4-M6	
Coupling flange, tool side			ISO 9409-1-63-4-M6
Dimensions X x Y x Z*	[mm]	80/101/28.5	80/88/18
Min./max. ambient temperature	[°C]	5/60	5/60
Dimensions Ø D x Z*	[mm]		- x 18
Screw connection diagram		K	K
max. static tensile force Fz	[N]	1000	1000
Max. dynamic moment Mx/My	[Nm]	75	75
Max. dynamic moment Mz	[Nm]	48	48
Options and their characteristics			
Basic version		CMS 063-K-B	CMS 063-A-B
ID		1545321	1545322
Lock sensing		not possible	
Weight	[kg]	0.5	0.3
SHA version (-N)			CMS 063-A-N
ID			1545319
Weight	[kg]		0.27
Tool-side connection			Ø63, 4xM8

* *Please note that the heights of the change master (ZK) and change adapter (ZA) differ. The sum represents the total height of a coupled change system.

CMS 063

Manual change system

SHA version (-N)

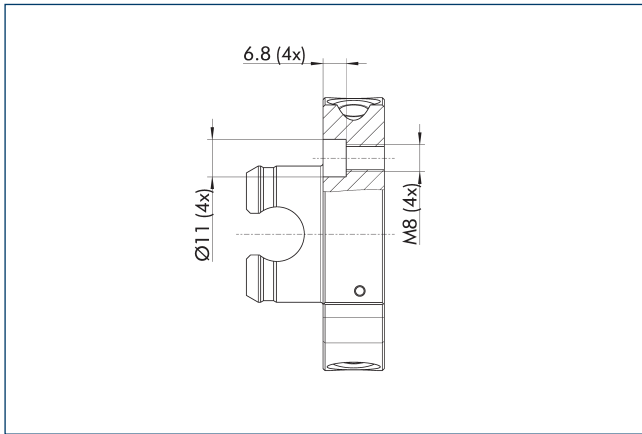

The SHA version has the same screw-on pattern on the tool side as the predecessor product SHS. Thus, existing SHS systems can be replaced by the CMS without changing the tools.

Pneumatic feed-through

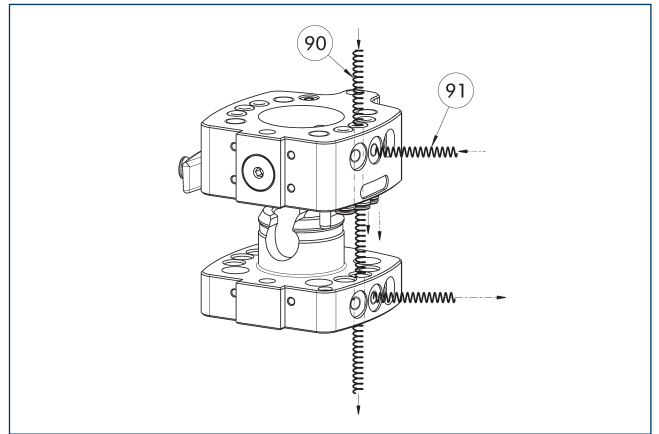

90 Feed-through axial 91 Feed-through radial

The change system features feed-throughs for pneumatics or vacuum integrated in the housing. They can be used hose-free via an adapter plate (axial) or with a hose (radial).

Electric feed-through module

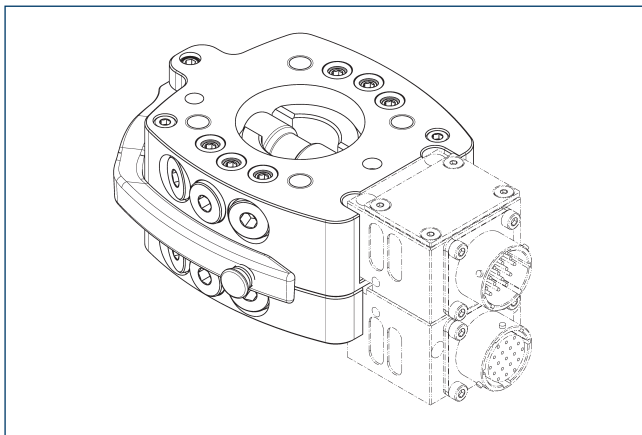

For detailed information, see the "COS" chapter in the catalog, or visit schunk.com.

Centering collar on CMS-K

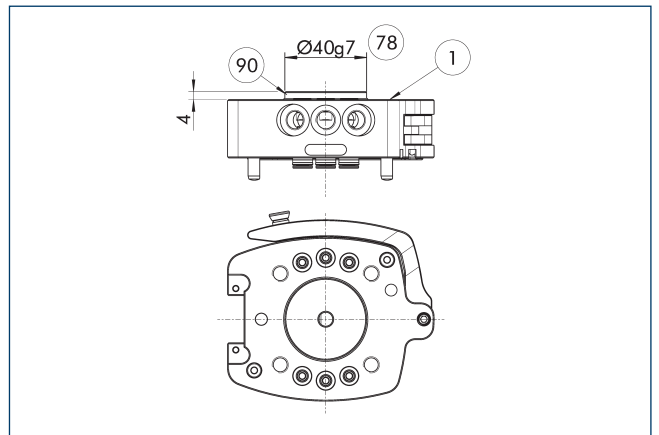

1 Robot-side connection 90 Centring disc
78 Fit for centering

Description	ID
Centering disc	
ZB-CMS-063-K CENTERING COLLAR	1574473

Serves as a fitting collar for centering on mechanical interfaces, e. g. on the robot.

Cable plug/cable extension

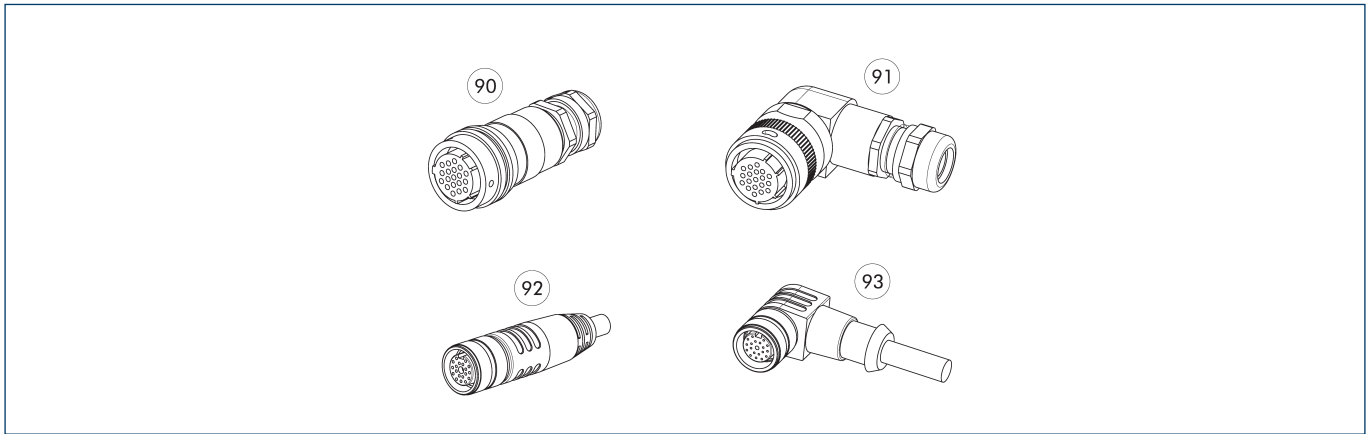

Other cable lengths on request.

- 90 Plug/socket straight
- 91 Connector/angled socket
- 92 Connector/straight socket with extension cable
- 93 Connector/angled socket with extension cable

Description	ID	Length [m]	Note
Angled cable connector, robot-side			
KBU-B-W 19P	0301294		Bayonet, 19 pins, socket, angled
Angled cable connector, tool-side			
KST-B-W 19P	0301295		Bayonet, 19 pins, plug, angled
Angled cable connector with cable, robot-side			
KA BW19B-L 19P-0300	0302179	3	Bayonet, 19 pins, socket, angled, 3 m cable, open wire strands
KA BW19B-L 19P-0500	0302190	5	Bayonet, 19 pins, socket, angled, 5 m cable, open wire strands
KA BW19F-L 19P-0500	0302172	5	M16, 19 pins, socket, angled, 5 m cable, open wire strands
KA BW19F-L 19P-1000	0302173	10	M16, 19 pins, socket, angled, 10 m cable, open wire strands
KA BW26B-L 26P-0300	0302185	3	Bayonet, 26 pins, socket, angled, 3 m cable, open wire strands
KA BW26B-L 26P-0500	0302186	5	Bayonet, 26 pins, socket, angled, 5 m cable, open wire strands
Angled cable connector with cable, tool-side			
KA SW19B-L 19P-0300	0302191	3	Bayonet, 19 pins, plug, angled, 3 m cable, open wire strands
KA SW19F-L 19P-0300	0302175	3	M16, 19 pins, plug, angled, 3 m cable, open wire strands
KA SW26B-L 26P-0300	0302187	3	Bayonet, 26 pins, plug, angled, 3 m cable, open wire strands
Straight cable connector, robot-side			
KST-B-G 19P	0301283		Bayonet, 19 pins, socket, straight
Straight cable connector, tool-side			
KAS-19B-A-0-C	0301284		Bayonet, 19 pins, plug, straight
Straight cable connector with cable, robot-side			
KA BG19B-L 19P-0300	0302176	3	Bayonet, 19 pins, socket, straight, 3 m cable, open wire strands
KA BG19B-L 19P-0500	0302177	5	Bayonet, 19 pins, socket, straight, 5 m cable, open wire strands
KA BG19F-L 19P-0500	0302170	5	M16, 19 pins, socket, straight, 5 m cable, open wire strands
KA BG19F-L 19P-1000	0302171	10	M16, 19 pins, socket, straight, 10 m cable, open wire strands
KA BG26B-L 26P-0300	0302192	3	Bayonet, 26 pins, socket, straight, 3 m cable, open wire strands
KA BG26B-L 26P-0500	0302193	5	Bayonet, 26 pins, socket, straight, 5 m cable, open wire strands
Straight cable connector with cable, tool-side			
KA SG19B-L 19P-0300	0302178	3	
KA SG19F-L 19P-0300	0302174	3	M16, 19 pins, plug, straight, 3 m cable, open wire strands
KA SG26B-L 26P-0300	0302184	3	Bayonet, 26 pins, plug, straight, 3 m cable, open wire strands
Cable extension			
KA BG08-L 8AP-0500	0302180		
KA BW08-L 8AP-0500	0302182		
KA SG08-L 8AP-0200	0302181		
KA SW08-L 8AP-0200	0302183		

① Detailed information and further cable connectors can be found at schunk.com

Monitoring via inductive proximity switches

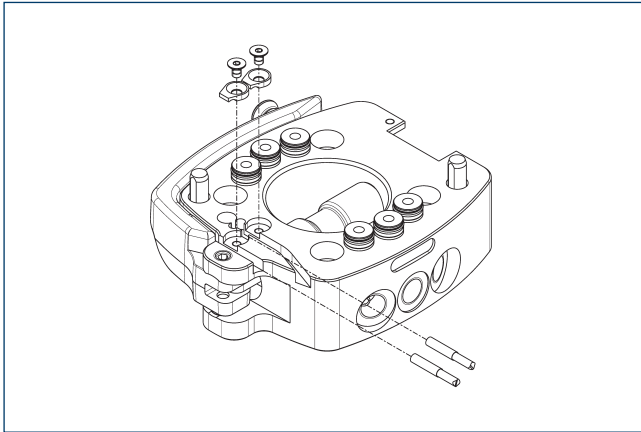

The CMS-K is prepared for locking monitoring as well as tool presence. One attachment kit each is required for this. Each attachment kit includes one sensor and one bracket incl. a screw.

Description	ID	
Robot side		
AS-CMS-K-IN30K	1548743	

ⓘ This attachment kit is optional and must be ordered separately as an accessory.

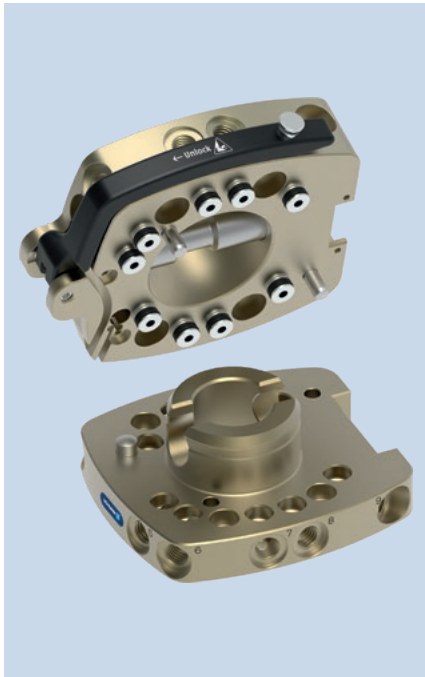

Load diagram

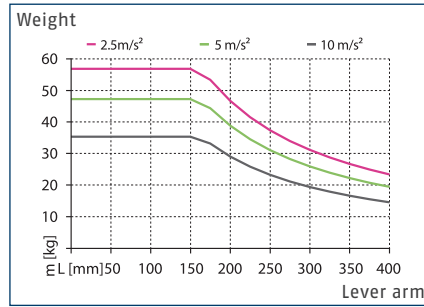

Maximum handling weight as a function of acceleration and lever arm (by M_x/M_y). The diagram does not replace the technical design.

Dimensions and maximum loads

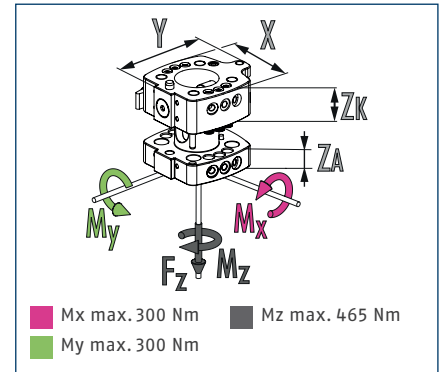

ⓘ This is the sum of all static loads that are permitted to act on the change system to ensure error-free functioning.

Technical data

Description		CMS 080-K	CMS 080-A
		Manual change head	Manual change adapter
ID		1545324	1545325
Recommended handling weight	[kg]	36	36
Lock sensing		optional	
Tool presence monitoring		optional	
Repeat accuracy	[mm]	0.02	0.02
Weight	[kg]	0.81	0.43
Number of pneumatic feed-throughs		9	9
Feed-throughs for radial use		9	9
Air connection thread pneumatic feed-through (radial)		G1/8"	G1/8"
Robot-side coupling flange		ISO 9409-1-80-6-M8	
Coupling flange, tool side			ISO 9409-1-80-6-M8
Dimensions X x Y x Z*	[mm]	100/123/30	100/108/18
Min./max. ambient temperature	[°C]	5/60	5/60
Dimensions \varnothing D x Z*	[mm]		- x 18
Screw connection diagram		K	K
max. static tensile force F_z	[N]	1600	1600
Max. dynamic moment M_x/M_y	[Nm]	115	115
Max. dynamic moment M_z	[Nm]	75	75
Options and their characteristics			
Basic version		CMS 080-K-B	CMS 080-A-B
ID		1545360	1545362
Lock sensing		not possible	
Weight	[kg]	0.83	0.47
SHA version (-N)			CMS 080-A-N
ID			1545327
Weight	[kg]		0.42
Tool-side connection			\varnothing 80, 4xM10

* *Please note that the heights of the change master (ZK) and change adapter (ZA) differ. The sum represents the total height of a coupled change system.

SHA version (-N)

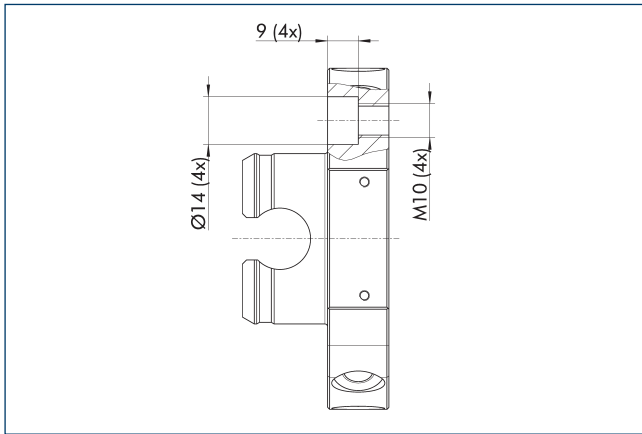

The SHA version has the same screw-on pattern on the tool side as the predecessor product SHS. Thus, existing SHS systems can be replaced by the CMS without changing the tools.

Pneumatic feed-through

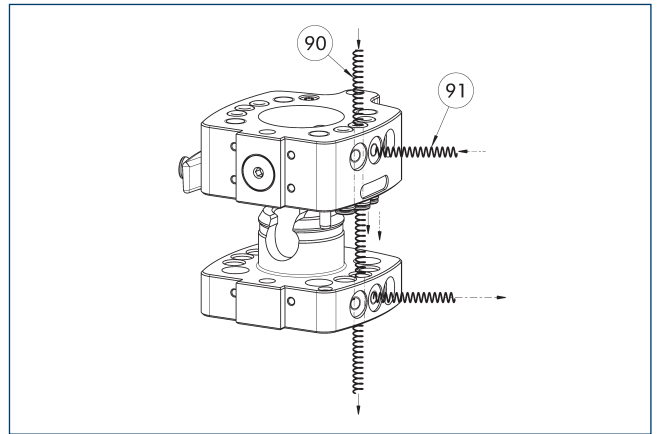

90 Feed-through axial

91 Feed-through radial

The change system features feed-throughs for pneumatics or vacuum integrated in the housing. They can be used hose-free via an adapter plate (axial) or with a hose (radial).

Electric feed-through module

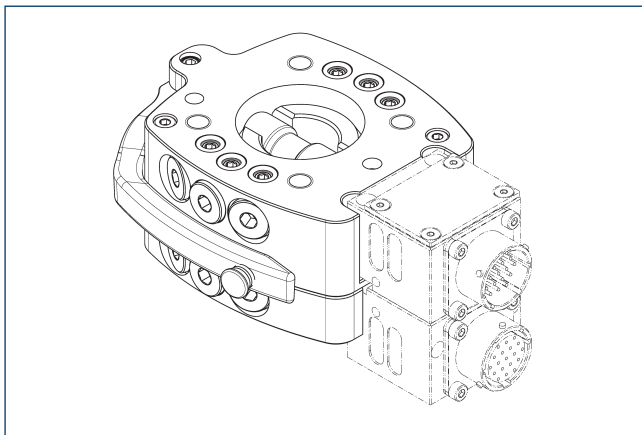

For detailed information, see the "COS" chapter in the catalog, or visit schunk.com.

Centering collar on CMS-K

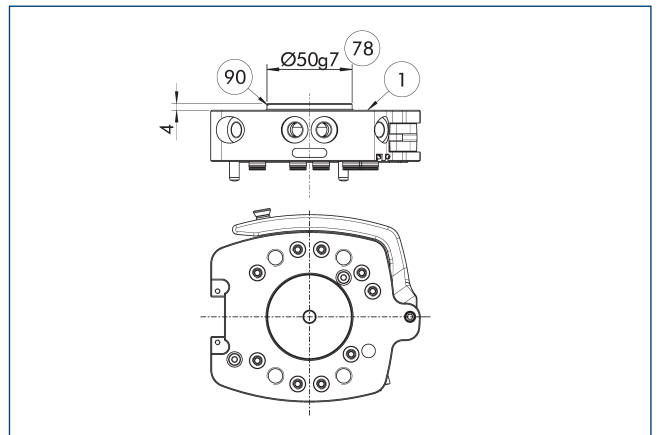

1 Robot-side connection

90 Centring disc

78 Fit for centering

Description	ID
Centering disc	
ZB-CMS-080-K CENTERING COLLAR	1574474

Serves as a fitting collar for centering on mechanical interfaces, e. g. on the robot.

Cable plug/cable extension

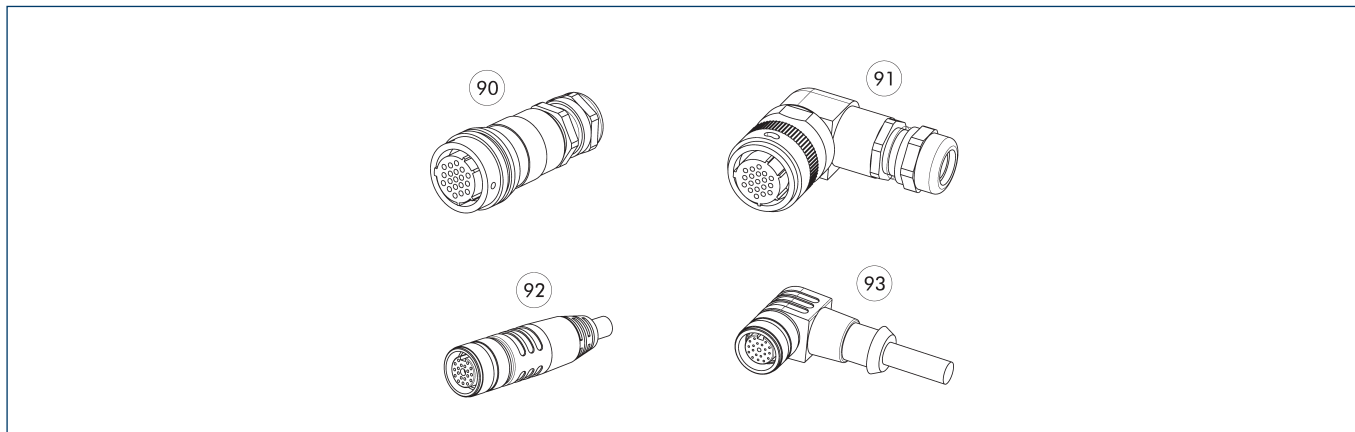

Other cable lengths on request.

- 90 Plug/socket straight
- 91 Connector/angled socket
- 92 Connector/straight socket with extension cable
- 93 Connector/angled socket with extension cable

Description	ID	Length [m]	Note
Angled cable connector, robot-side			
KBU-B-W 19P	0301294		Bayonet, 19 pins, socket, angled
Angled cable connector, tool-side			
KST-B-W 19P	0301295		Bayonet, 19 pins, plug, angled
Angled cable connector with cable, robot-side			
KA BW19B-L 19P-0300	0302179	3	Bayonet, 19 pins, socket, angled, 3 m cable, open wire strands
KA BW19B-L 19P-0500	0302190	5	Bayonet, 19 pins, socket, angled, 5 m cable, open wire strands
KA BW19F-L 19P-0500	0302172	5	M16, 19 pins, socket, angled, 5 m cable, open wire strands
KA BW19F-L 19P-1000	0302173	10	M16, 19 pins, socket, angled, 10 m cable, open wire strands
KA BW26B-L 26P-0300	0302185	3	Bayonet, 26 pins, socket, angled, 3 m cable, open wire strands
KA BW26B-L 26P-0500	0302186	5	Bayonet, 26 pins, socket, angled, 5 m cable, open wire strands
Angled cable connector with cable, tool-side			
KA SW19B-L 19P-0300	0302191	3	Bayonet, 19 pins, plug, angled, 3 m cable, open wire strands
KA SW19F-L 19P-0300	0302175	3	M16, 19 pins, plug, angled, 3 m cable, open wire strands
KA SW26B-L 26P-0300	0302187	3	Bayonet, 26 pins, plug, angled, 3 m cable, open wire strands
Straight cable connector, robot-side			
KST-B-G 19P	0301283		Bayonet, 19 pins, socket, straight
Straight cable connector, tool-side			
KAS-19B-A-0-C	0301284		Bayonet, 19 pins, plug, straight
Straight cable connector with cable, robot-side			
KA BG19B-L 19P-0300	0302176	3	Bayonet, 19 pins, socket, straight, 3 m cable, open wire strands
KA BG19B-L 19P-0500	0302177	5	Bayonet, 19 pins, socket, straight, 5 m cable, open wire strands
KA BG19F-L 19P-0500	0302170	5	M16, 19 pins, socket, straight, 5 m cable, open wire strands
KA BG19F-L 19P-1000	0302171	10	M16, 19 pins, socket, straight, 10 m cable, open wire strands
KA BG26B-L 26P-0300	0302192	3	Bayonet, 26 pins, socket, straight, 3 m cable, open wire strands
KA BG26B-L 26P-0500	0302193	5	Bayonet, 26 pins, socket, straight, 5 m cable, open wire strands
Straight cable connector with cable, tool-side			
KA SG19B-L 19P-0300	0302178	3	
KA SG19F-L 19P-0300	0302174	3	M16, 19 pins, plug, straight, 3 m cable, open wire strands
KA SG26B-L 26P-0300	0302184	3	Bayonet, 26 pins, plug, straight, 3 m cable, open wire strands
Cable extension			
KA BG08-L 8AP-0500	0302180		
KA BW08-L 8AP-0500	0302182		
KA SG08-L 8AP-0200	0302181		
KA SW08-L 8AP-0200	0302183		

① Detailed information and further cable connectors can be found at schunk.com

Monitoring via inductive proximity switches

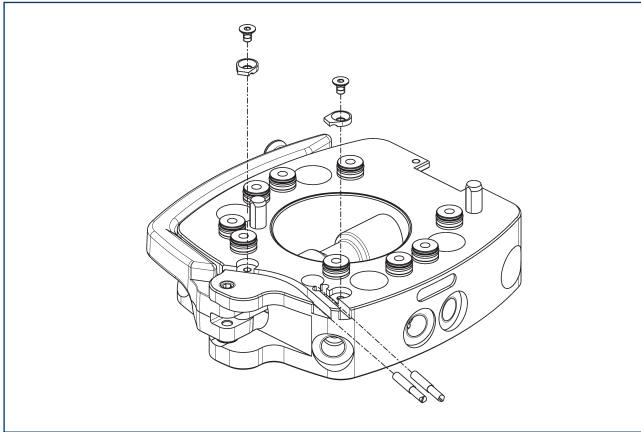

The CMS-K is prepared for locking monitoring as well as tool presence. One attachment kit each is required for this. Each attachment kit includes one sensor and one bracket incl. a screw.

Description	ID	
Robot side		
AS-CMS-K-IN30K	1548743	

ⓘ This attachment kit is optional and must be ordered separately as an accessory.

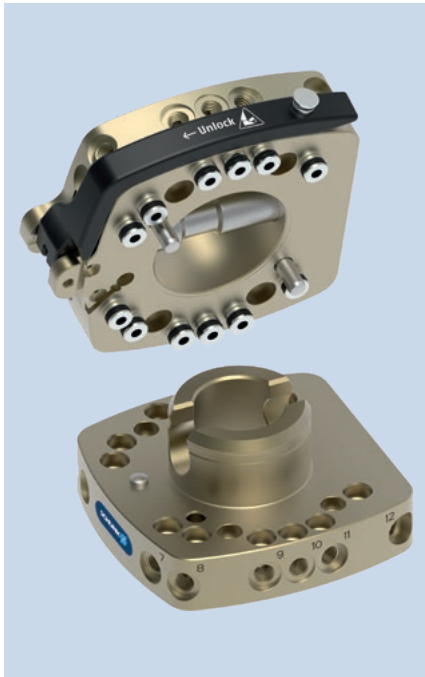

Load diagram

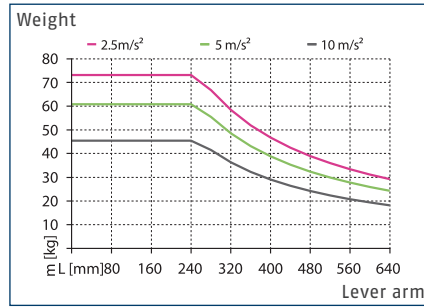

Maximum handling weight as a function of acceleration and lever arm (by M_x/M_y). The diagram does not replace the technical design.

Dimensions and maximum loads

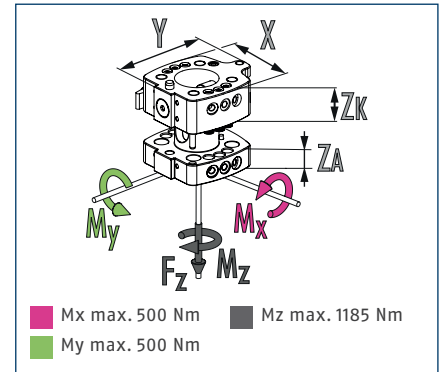

ⓘ This is the sum of all static loads that are permitted to act on the change system to ensure error-free functioning.

Technical data

Description		CMS 100-K	CMS 100-A
		Manual change head	Manual change adapter
ID		1545364	1545366
Recommended handling weight	[kg]	43	43
Lock sensing		optional	
Tool presence monitoring		optional	
Repeat accuracy	[mm]	0.02	0.02
Weight	[kg]	1.65	1.04
Number of pneumatic feed-throughs		12	12
Feed-throughs for radial use		12	12
Air connection thread pneumatic feed-through (radial)		G1/8"	G1/8"
Robot-side coupling flange		ISO 9409-1-100-6-M8	
Coupling flange, tool side			ISO 9409-1-100-6-M8
Dimensions X x Y x Z*	[mm]	125/142.5/38	125/125/28
Min./max. ambient temperature	[°C]	5/60	5/60
Dimensions \varnothing D x Z*	[mm]		- x 28
Screw connection diagram		J	J
max. static tensile force F_z	[N]	1800	1800
Max. dynamic moment M_x/M_y	[Nm]	230	230
Max. dynamic moment M_z	[Nm]	230	230
Options and their characteristics			
Basic version		CMS 100-K-B	CMS 100-A-B
ID		1545370	1545387
Lock sensing		not possible	
Weight	[kg]	1.65	1.11
SHA version (-N)			CMS 100-A-N
ID			1545368
Weight	[kg]		1.03
Tool-side connection			\varnothing 100, 4xM10

* *Please note that the heights of the change master (ZK) and change adapter (ZA) differ. The sum represents the total height of a coupled change system.

Main view

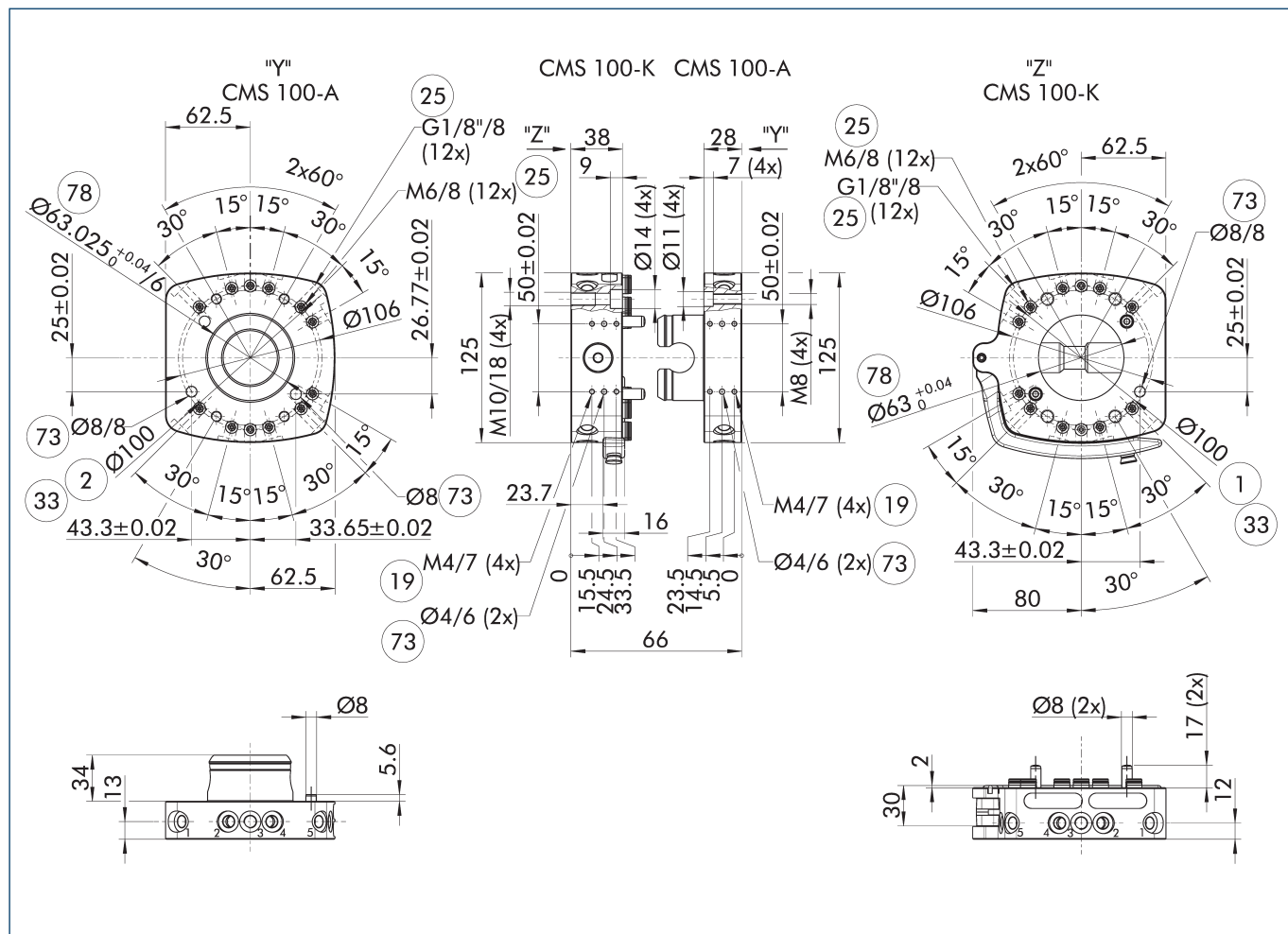

The main view shows the unit in its basic version.

- ① Robot-side connection
- ② Tool-side connection
- ③ DIN ISO-9409 bolt circle
- ④ Fit for centering pins
- ⑤ Mounting surface for options
- ⑥ Fit for centering
- ⑦ Pneumatic feed-throughs

Interference Contour when locking/unlocking

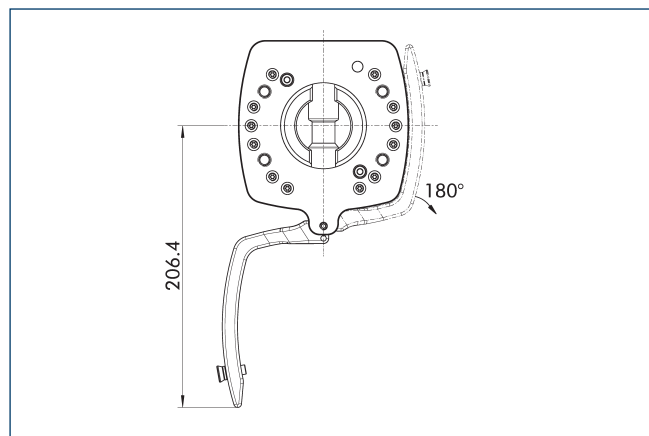

The drawing shows the interfering contour when locking and unlocking. The specified values may vary depending on the opening angle of the locking lever.

Basic version (-B)

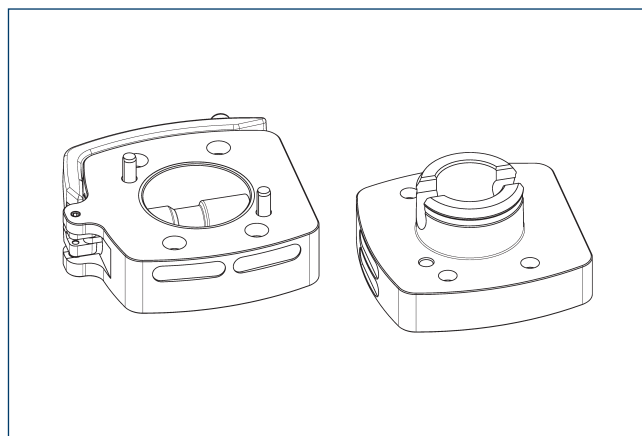

The basic version is a simplified basic design variant without integrated air feed-throughs and without monitoring options.

SHA version (-N)

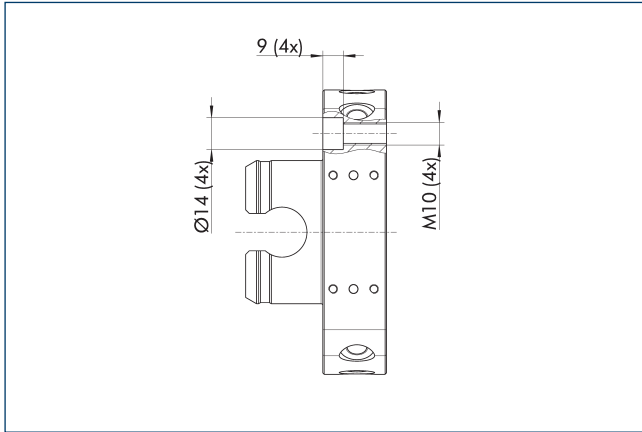

The SHA version has the same screw-on pattern on the tool side as the predecessor product SHS. Thus, existing SHS systems can be replaced by the CMS without changing the tools.

Pneumatic feed-through

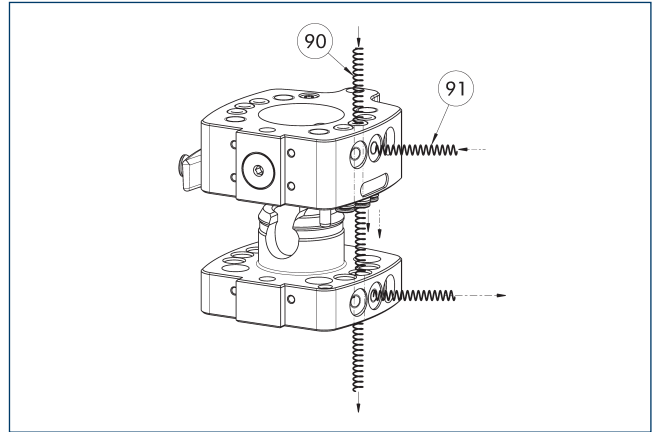

90 Feed-through axial

91 Feed-through radial

The change system features feed-throughs for pneumatics or vacuum integrated in the housing. They can be used hose-free via an adapter plate (axial) or with a hose (radial).

Electric feed-through module

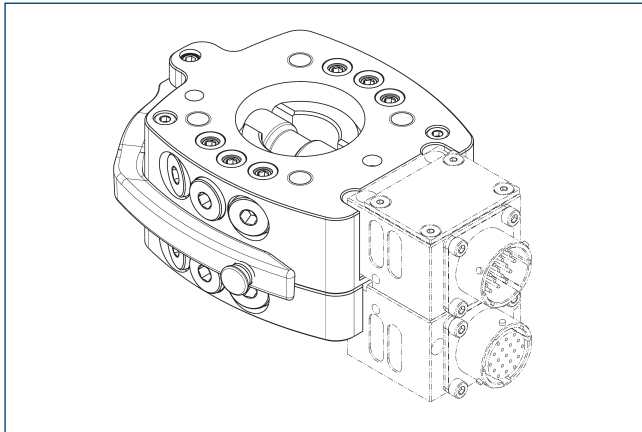

For detailed information, see the "COS" chapter in the catalog, or visit schunk.com.

Centering collar on CMS-K

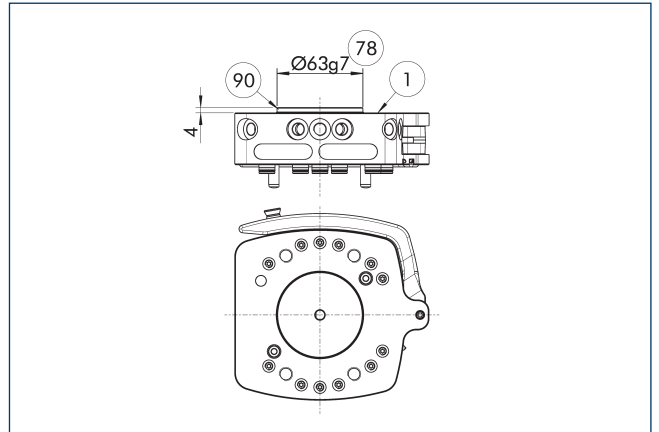

1 Robot-side connection

90 Centring disc

78 Fit for centering

Description	ID
Centering disc	
ZB-CMS-100-K CENTERING COLLAR	1574475

Serves as a fitting collar for centering on mechanical interfaces, e. g. on the robot.

Cable plug/cable extension

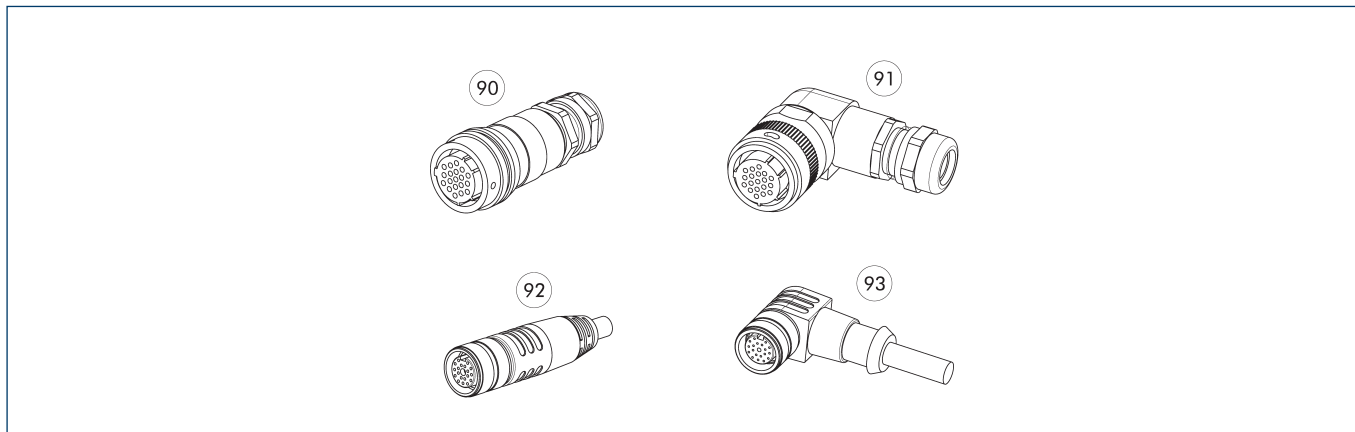

Other cable lengths on request.

- 90 Plug/socket straight
- 91 Connector/angled socket
- 92 Connector/straight socket with extension cable
- 93 Connector/angled socket with extension cable

Description	ID	Length [m]	Note
Angled cable connector, robot-side			
KBU-B-W 19P	0301294		Bayonet, 19 pins, socket, angled
Angled cable connector, tool-side			
KST-B-W 19P	0301295		Bayonet, 19 pins, plug, angled
Angled cable connector with cable, robot-side			
KA BW19B-L 19P-0300	0302179	3	Bayonet, 19 pins, socket, angled, 3 m cable, open wire strands
KA BW19B-L 19P-0500	0302190	5	Bayonet, 19 pins, socket, angled, 5 m cable, open wire strands
KA BW19F-L 19P-0500	0302172	5	M16, 19 pins, socket, angled, 5 m cable, open wire strands
KA BW19F-L 19P-1000	0302173	10	M16, 19 pins, socket, angled, 10 m cable, open wire strands
KA BW26B-L 26P-0300	0302185	3	Bayonet, 26 pins, socket, angled, 3 m cable, open wire strands
KA BW26B-L 26P-0500	0302186	5	Bayonet, 26 pins, socket, angled, 5 m cable, open wire strands
Angled cable connector with cable, tool-side			
KA SW19B-L 19P-0300	0302191	3	Bayonet, 19 pins, plug, angled, 3 m cable, open wire strands
KA SW19F-L 19P-0300	0302175	3	M16, 19 pins, plug, angled, 3 m cable, open wire strands
KA SW26B-L 26P-0300	0302187	3	Bayonet, 26 pins, plug, angled, 3 m cable, open wire strands
Straight cable connector, robot-side			
KST-B-G 19P	0301283		Bayonet, 19 pins, socket, straight
Straight cable connector, tool-side			
KAS-19B-A-0-C	0301284		Bayonet, 19 pins, plug, straight
Straight cable connector with cable, robot-side			
KA BG19B-L 19P-0300	0302176	3	Bayonet, 19 pins, socket, straight, 3 m cable, open wire strands
KA BG19B-L 19P-0500	0302177	5	Bayonet, 19 pins, socket, straight, 5 m cable, open wire strands
KA BG19F-L 19P-0500	0302170	5	M16, 19 pins, socket, straight, 5 m cable, open wire strands
KA BG19F-L 19P-1000	0302171	10	M16, 19 pins, socket, straight, 10 m cable, open wire strands
KA BG26B-L 26P-0300	0302192	3	Bayonet, 26 pins, socket, straight, 3 m cable, open wire strands
KA BG26B-L 26P-0500	0302193	5	Bayonet, 26 pins, socket, straight, 5 m cable, open wire strands
Straight cable connector with cable, tool-side			
KA SG19B-L 19P-0300	0302178	3	
KA SG19F-L 19P-0300	0302174	3	M16, 19 pins, plug, straight, 3 m cable, open wire strands
KA SG26B-L 26P-0300	0302184	3	Bayonet, 26 pins, plug, straight, 3 m cable, open wire strands
Cable extension			
KA BG08-L 8AP-0500	0302180		
KA BW08-L 8AP-0500	0302182		
KA SG08-L 8AP-0200	0302181		
KA SW08-L 8AP-0200	0302183		

① Detailed information and further cable connectors can be found at schunk.com

Monitoring via inductive proximity switches

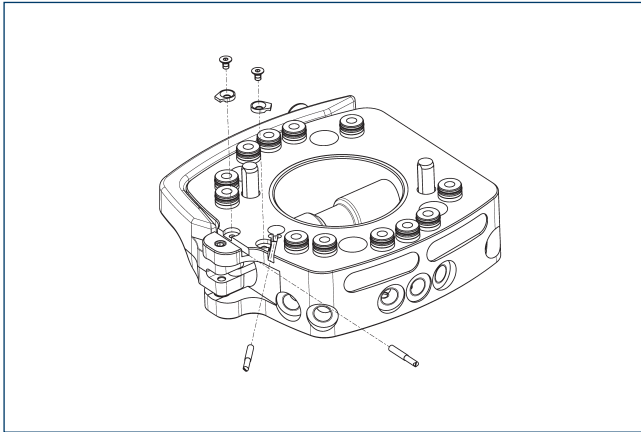

The CMS-K is prepared for locking monitoring as well as tool presence. One attachment kit each is required for this. Each attachment kit includes one sensor and one bracket incl. a screw.

Description	ID	
Robot side		
AS-CMS-K-IN30K	1548743	

ⓘ This attachment kit is optional and must be ordered separately as an accessory.



Load diagram

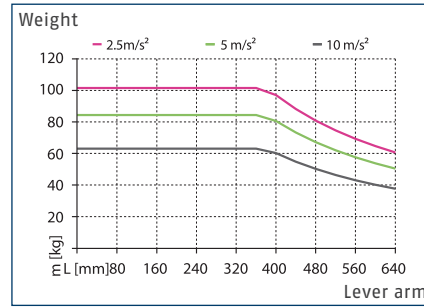

Maximum handling weight as a function of acceleration and lever arm (by M_x/M_y). The diagram does not replace the technical design.

Dimensions and maximum loads

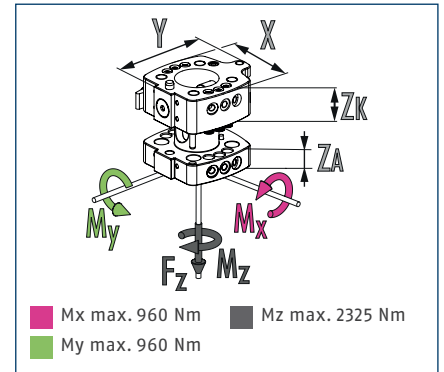

ⓘ This is the sum of all static loads that are permitted to act on the change system to ensure error-free functioning.

Technical data

Description		CMS 125-K	CMS 125-A
		Manual change head	Manual change adapter
ID		1545393	1545397
Recommended handling weight	[kg]	58	58
Lock sensing		optional	
Tool presence monitoring		optional	
Repeat accuracy	[mm]	0.02	0.02
Weight	[kg]	3.37	1.7
Number of pneumatic feed-throughs		12	12
Feed-throughs for radial use		12	12
Air connection thread pneumatic feed-through (radial)		G1/4"	G1/4"
Robot-side coupling flange		ISO 9409-1-125-6-M10	
Coupling flange, tool side			ISO 9409-1-125-6-M10
Dimensions X x Y x Z*	[mm]	160/183/38	160/160/28
Min./max. ambient temperature	[°C]	5/60	5/60
Dimensions Ø D x Z*	[mm]		- x 28
Screw connection diagram		J	J
max. static tensile force Fz	[N]	3000	3000
Max. dynamic moment Mx/My	[Nm]	478	478
Max. dynamic moment Mz	[Nm]	465	465
Options and their characteristics			
Basic version		CMS 125-K-B	CMS 125-A-B
ID		1545403	1545404
Lock sensing		not possible	
Weight	[kg]	3.46	1.85
SHA version (-N)			CMS 125-A-N
ID			1545401
Weight	[kg]		1.7
Tool-side connection			Ø125, 4xM12

* *Please note that the heights of the change master (ZK) and change adapter (ZA) differ. The sum represents the total height of a coupled change system.

Main view

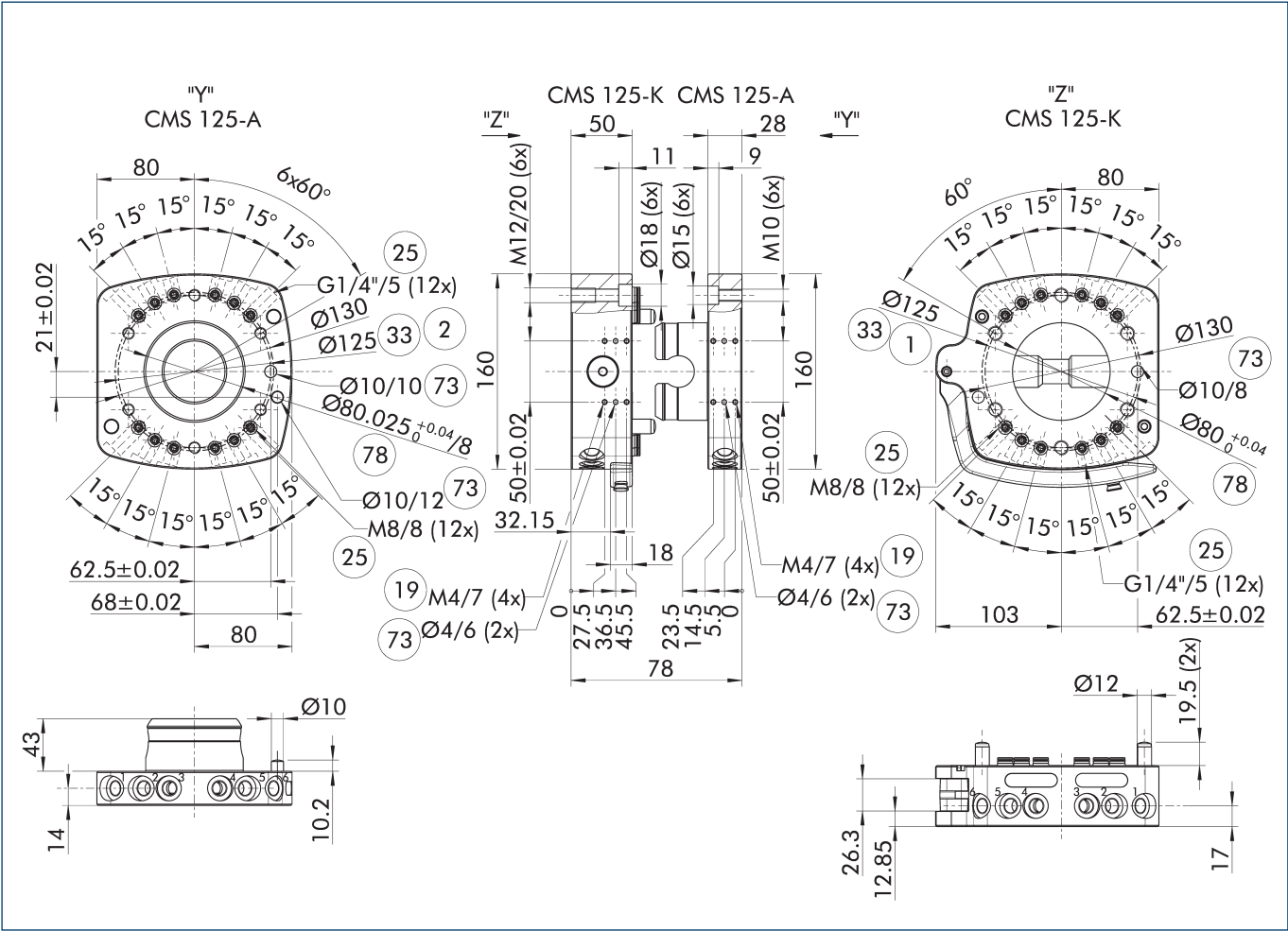

The main view shows the unit in its basic version.

- ① Robot-side connection
- ② Tool-side connection
- ⑱ Mounting surface for options
- ⑳ Pneumatic feed-throughs
- ⑳ DIN ISO-9409 bolt circle
- ⑳ Fit for centering pins
- ⑳ Fit for centering

Interference Contour when locking/unlocking

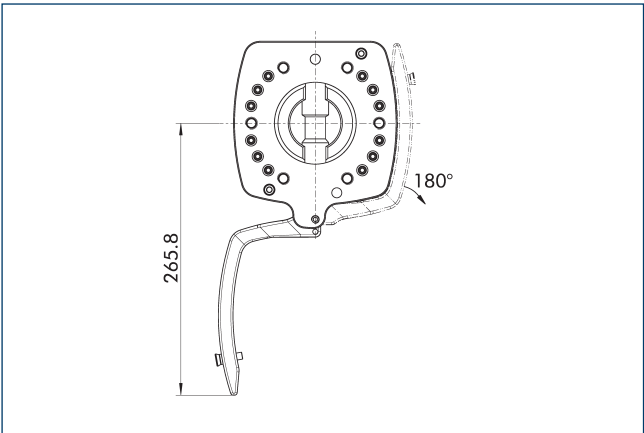

The drawing shows the interfering contour when locking and unlocking. The specified values may vary depending on the opening angle of the locking lever.

Basic version (-B)

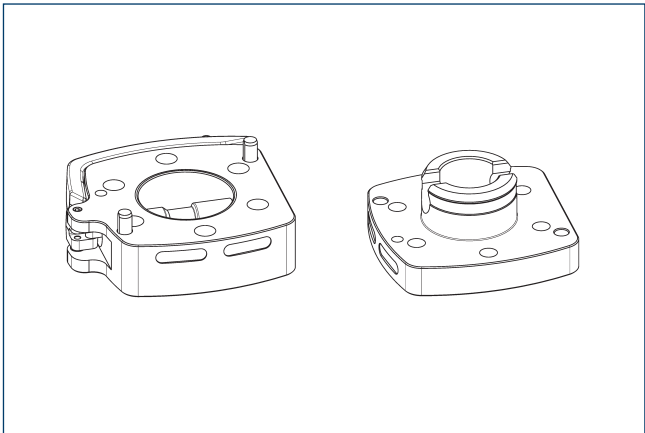

The basic version is a simplified basic design variant without integrated air feed-throughs and without monitoring options.

SHA version (-N)

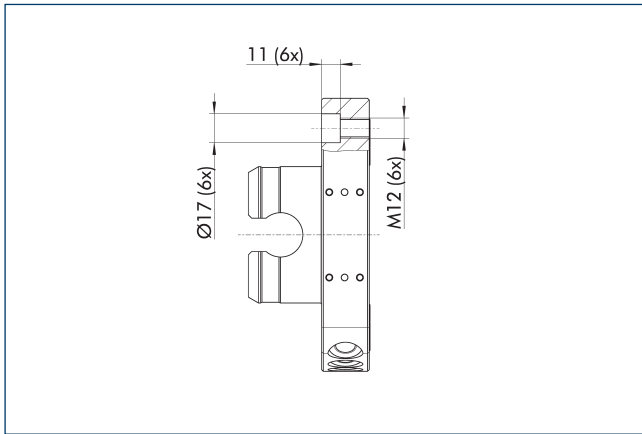

The SHA version has the same screw-on pattern on the tool side as the predecessor product SHS. Thus, existing SHS systems can be replaced by the CMS without changing the tools.

Pneumatic feed-through

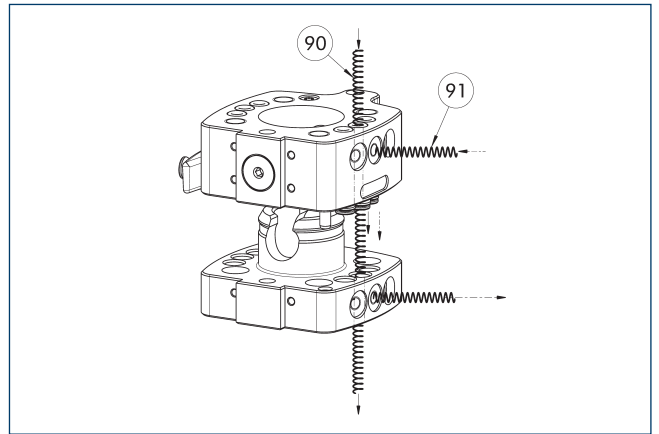

90 Feed-through axial

91 Feed-through radial

The change system features feed-throughs for pneumatics or vacuum integrated in the housing. They can be used hose-free via an adapter plate (axial) or with a hose (radial).

Electric feed-through module

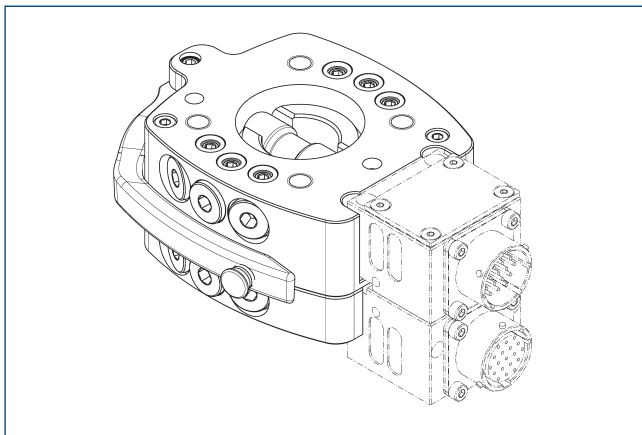

For detailed information, see the "COS" chapter in the catalog, or visit schunk.com.

Centering collar on CMS-K

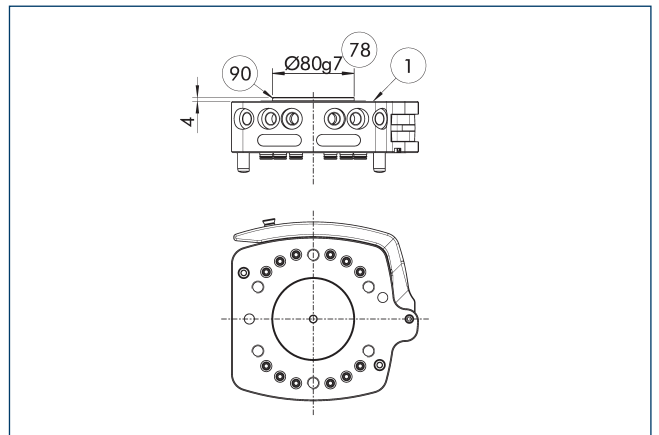

1 Robot-side connection

90 Centring disc

78 Fit for centering

Description	ID
Centering disc	
ZB-CMS-125-K CENTERING COLLAR	1574477

Serves as a fitting collar for centering on mechanical interfaces, e. g. on the robot.

Cable plug/cable extension

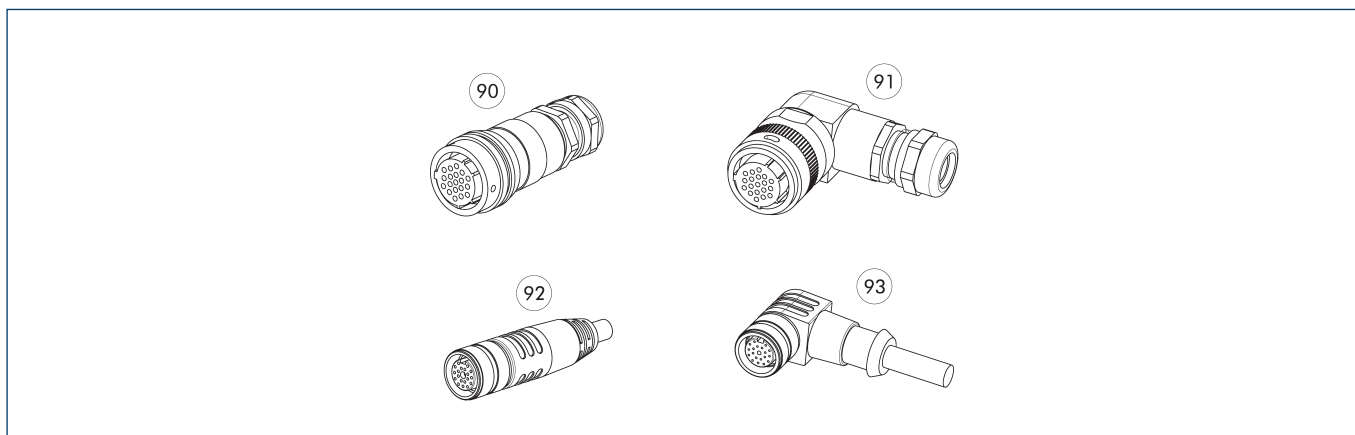

Other cable lengths on request.

- 90 Plug/socket straight
- 91 Connector/angled socket
- 92 Connector/straight socket with extension cable
- 93 Connector/angled socket with extension cable

Description	ID	Length [m]	Note
Angled cable connector, robot-side			
KBU-B-W 19P	0301294		Bayonet, 19 pins, socket, angled
Angled cable connector, tool-side			
KST-B-W 19P	0301295		Bayonet, 19 pins, plug, angled
Angled cable connector with cable, robot-side			
KA BW19B-L 19P-0300	0302179	3	Bayonet, 19 pins, socket, angled, 3 m cable, open wire strands
KA BW19B-L 19P-0500	0302190	5	Bayonet, 19 pins, socket, angled, 5 m cable, open wire strands
KA BW19F-L 19P-0500	0302172	5	M16, 19 pins, socket, angled, 5 m cable, open wire strands
KA BW19F-L 19P-1000	0302173	10	M16, 19 pins, socket, angled, 10 m cable, open wire strands
KA BW26B-L 26P-0300	0302185	3	Bayonet, 26 pins, socket, angled, 3 m cable, open wire strands
KA BW26B-L 26P-0500	0302186	5	Bayonet, 26 pins, socket, angled, 5 m cable, open wire strands
Angled cable connector with cable, tool-side			
KA SW19B-L 19P-0300	0302191	3	Bayonet, 19 pins, plug, angled, 3 m cable, open wire strands
KA SW19F-L 19P-0300	0302175	3	M16, 19 pins, plug, angled, 3 m cable, open wire strands
KA SW26B-L 26P-0300	0302187	3	Bayonet, 26 pins, plug, angled, 3 m cable, open wire strands
Straight cable connector, robot-side			
KST-B-G 19P	0301283		Bayonet, 19 pins, socket, straight
Straight cable connector, tool-side			
KAS-19B-A-0-C	0301284		Bayonet, 19 pins, plug, straight
Straight cable connector with cable, robot-side			
KA BG19B-L 19P-0300	0302176	3	Bayonet, 19 pins, socket, straight, 3 m cable, open wire strands
KA BG19B-L 19P-0500	0302177	5	Bayonet, 19 pins, socket, straight, 5 m cable, open wire strands
KA BG19F-L 19P-0500	0302170	5	M16, 19 pins, socket, straight, 5 m cable, open wire strands
KA BG19F-L 19P-1000	0302171	10	M16, 19 pins, socket, straight, 10 m cable, open wire strands
KA BG26B-L 26P-0300	0302192	3	Bayonet, 26 pins, socket, straight, 3 m cable, open wire strands
KA BG26B-L 26P-0500	0302193	5	Bayonet, 26 pins, socket, straight, 5 m cable, open wire strands
Straight cable connector with cable, tool-side			
KA SG19B-L 19P-0300	0302178	3	
KA SG19F-L 19P-0300	0302174	3	M16, 19 pins, plug, straight, 3 m cable, open wire strands
KA SG26B-L 26P-0300	0302184	3	Bayonet, 26 pins, plug, straight, 3 m cable, open wire strands
Cable extension			
KA BG08-L 8AP-0500	0302180		
KA BW08-L 8AP-0500	0302182		
KA SG08-L 8AP-0200	0302181		
KA SW08-L 8AP-0200	0302183		

① Detailed information and further cable connectors can be found at schunk.com

Monitoring via inductive proximity switches

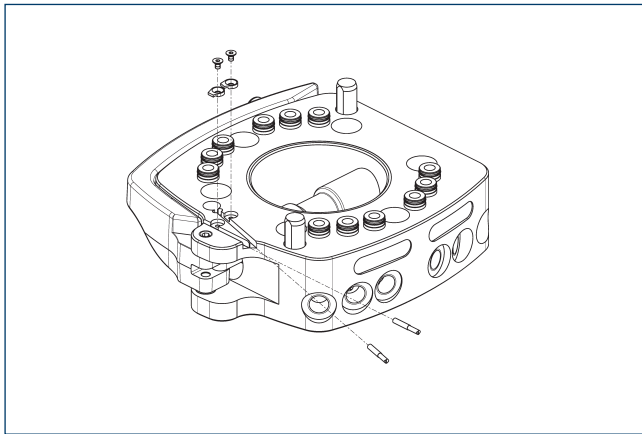

The CMS-K is prepared for locking monitoring as well as tool presence. One attachment kit each is required for this. Each attachment kit includes one sensor and one bracket incl. a screw.

Description	ID	
Robot side		
AS-CMS-K-IN30K	1548743	

ⓘ This attachment kit is optional and must be ordered separately as an accessory.



SCHUNK SE & Co. KG

Spanntechnik

Greiftechnik

Automatisierungstechnik

Bahnhofstr. 106 - 134

D-74348 Lauffen/Neckar

Tel. +49-7133-103-0

Fax +49-7133-103-2399

info@de.schunk.com

schunk.com

Folgen Sie uns | *Follow us*

