



Assembly- and Operating Manual

PZB-plus

3-Finger-Centric Gripper

Translation of the original manual

Hand in hand for tomorrow

Imprint

Copyright:

This manual is protected by copyright. The author is SCHUNK SE & Co. KG.
All rights reserved.

Technical changes:

We reserve the right to make alterations for the purpose of technical improvement.

Document number: 389366

Version: 14.00 | 08/07/2024 | en

Dear Customer,

Thank you for trusting our products and our family-owned company, the leading technology supplier of robots and production machines.

Our team is always available to answer any questions on this product and other solutions. Ask us questions and challenge us. We will find a solution!

Best regards,

Your SCHUNK team

Customer Management

Tel. +49-7133-103-2503

Fax +49-7133-103-2189

cmg@de.schunk.com



Please read the operating manual in full and keep it close to the product.

Table of Contents

1	General	5
1.1	About this manual.....	5
1.1.1	Presentation of Warning Labels	5
1.1.2	Symbol definition.....	6
1.1.3	Applicable documents	6
1.1.4	Sizes.....	6
1.1.5	Variants	6
1.2	Warranty	6
1.3	Scope of delivery.....	7
1.3.1	Accessories kit	7
1.4	Accessories	7
1.4.1	Sealing kit	7
2	Basic safety notes	8
2.1	Intended use.....	8
2.2	Constructional changes.....	8
2.3	Spare parts	8
2.4	Gripper fingers	8
2.5	Ambient conditions and operating conditions	9
2.6	Personnel qualification	9
2.7	Personal protective equipment	10
2.8	Notes on safe operation.....	10
2.9	Transport.....	11
2.10	Malfunctions	11
2.11	Disposal	11
2.12	Fundamental dangers	11
2.12.1	Protection during handling and assembly	12
2.12.2	Protection during commissioning and operation	12
2.12.3	Protection against dangerous movements	12
2.12.4	Protection against electric shock.....	13
2.13	Notes on particular risks	14
3	Technical data	16
4	Design and description	17
4.1	Design	17
4.2	Description	17
5	Assembly.....	18
5.1	Installing and connecting	18
5.2	Connections	20
5.2.1	Mechanical connection.....	20

5.2.2	Pneumatic connection.....	23
5.3	Mounting the sensor.....	25
5.3.1	Overview of sensors	25
5.3.2	Switch-off hysteresis for magnetic switches	25
5.3.3	Turn control cam	26
5.3.4	Setting dimensions	27
5.3.5	Mounting MMS 22 magnetic switch	28
5.3.6	Mounting MMS 22-PI1 programmable magnetic switch	29
5.3.7	Mounting programmable MMS 22-PI2 magnetic switch	30
5.3.8	Mounting programmable MMS-P 22 magnetic switch.....	31
5.3.9	Mounting programmable magnetic switch MMS-IOL.....	32
5.3.10	Mounting the reed switch RMS 80	34
5.3.11	Mounting inductive proximity switch IN 80	36
5.3.12	Mounting flexible position sensor FPS	38
5.3.13	Mounting the analog position sensor APS-M1	39
5.3.14	Mounting the analog position sensor APS-Z80	41
5.3.15	Mounting the radio system RSS-R1/T2.....	43
6	Troubleshooting.....	44
6.1	Product does not move.....	44
6.2	Product is not executing the complete stroke	44
6.3	Product is opening or closing abruptly	44
6.4	Gripping force is dropping.....	44
6.5	Product does not achieve the opening and closing times	45
6.6	Programmable magnetic switches not switching as desired	45
7	Maintenance	46
7.1	Notes.....	46
7.2	Maintenance intervals.....	46
7.3	Lubricants/Lubrication points.....	47
7.4	Disassembly and assembly	48
7.4.1	Dismantling (variant without gripping force maintenance).....	48
7.4.2	Disassembly (variant with gripping force maintenance "O.D. gripping") ..	48
7.4.3	Dismantling (variant with gripping force maintenance "I.D. gripping") ..	49
7.5	Notes for assembly	50
7.6	Screw tightening torques	50
7.7	Assembly drawing	50
8	Translation of the original declaration of incorporation	52
9	UKCA declaration of incorporation	53
10	Information on the RoHS Directive, REACH Regulation and Substances of Very High Concern (SVHC)	54

1 General

1.1 About this manual

This manual contains important information for a safe and appropriate use of the product.

This manual is an integral part of the product and must be kept accessible for the personnel at all times.

Before starting work, the personnel must have read and understood this operating manual. Prerequisite for safe working is the observance of all safety instructions in this manual.

In addition to these instructions, the documents listed under ► 1.1.3 [D 6] are applicable.

NOTE: The illustrations in this manual are intended to provide a basic understanding and may deviate from the actual version.

1.1.1 Presentation of Warning Labels

To make risks clear, the following signal words and symbols are used for safety notes.



⚠ DANGER

Dangers for persons!

Non-observance will inevitably cause irreversible injury or death.



⚠ WARNING

Dangers for persons!

Non-observance can lead to irreversible injury and even death.



⚠ CAUTION

Dangers for persons!

Non-observance can cause minor injuries.

CAUTION

Material damage!

Information about avoiding material damage.

1.1.2 Symbol definition

The following symbols are used in this manual:

■ Prerequisite for an action

1. Action 1

2. Action 2

⇒ Intermediate results

⇒ Final results

▶ 1.1.2 [📄 6]: chapter number and [page number] in hyperlinks

1.1.3 Applicable documents

- General terms of business *
- Catalog data sheet of the purchased product *
- Assembly and operating manuals of the accessories *

The documents labeled with an asterisk (*) can be downloaded from schunk.com/downloads.

1.1.4 Sizes

This operating manual applies to the following sizes:

- PZB-plus 50
- PZB-plus 64
- PZB-plus 80
- PZB-plus 100
- PZB-plus 125
- PZB-plus 160
- PZB-plus 200
- PZB-plus 240
- PZB-plus 300

1.1.5 Variants

This operating manual applies to the following variations:

- PZB-plus
- PZB-plus with gripping force maintenance O.D. gripping
- PZB-plus with gripping force maintenance I.D. gripping

1.2 Warranty

If the product is used as intended, the warranty is valid for 36 months from the ex-works delivery date under the following conditions:

- Observe the specified maintenance and lubrication intervals
- Observe the ambient conditions and operating conditions

Parts touching the workpiece and wear parts are not included in the warranty.

1.3 Scope of delivery

The scope of delivery includes

- 3-Finger-Centric Gripper PZB-plus in the version ordered
- Assembly and Operating Manual
- Accessory pack

1.3.1 Accessories kit

Content of the accessory pack:

- 6 x Centering sleeves for mounting
- 2 x O-ring for hose-free direct connection
- 2 x screw plug for hose connection
- 2x Cylinder pins for mounting

1.4 Accessories

A wide range of accessories are available for this product

For information regarding which accessory articles can be used with the corresponding product variants, see catalog data sheet.

1.4.1 Sealing kit

contents of the sealing kit, ► 7.7 [51].

Size	ID number
50	5518602
64	5518603
80	5518604
100	5518605
125	5518606
160	5518607
200	5523391
240	5523392
300	5522623

Tab.: ID. No. spare part kit "Seal kit"

2 Basic safety notes

2.1 Intended use

The product is designed exclusively for gripping and temporarily holding workpieces or objects.

- The product may only be used within the scope of its technical data, ▶ 3 [16].
- The product is intended for installation in a machine/ automated system. The applicable guidelines for the machine/ automated system must be observed and complied with.
- The product is intended for industrial and industry-oriented use. Its use outside enclosed spaces is only permitted if suitable protective measures are taken against outdoor exposure. The product is not suitable for use in salty air.
- The product can be used within the permissible load limits and technical data for holding workpieces during simple machining operations, but is not a clamping device according to EN 1550:1997+A1:2008.
- Appropriate use of the product includes compliance with all instructions in this manual.
- Any utilization that exceeds or differs from the appropriate use is regarded as misuse.

2.2 Constructional changes

Implementation of structural changes

Modifications, changes or reworking, e.g. additional threads, holes, or safety devices, can damage the product or impair its functionality or safety.

- Structural changes should only be made with the written approval of SCHUNK.

2.3 Spare parts

Use of unauthorized spare parts

Using unauthorized spare parts can endanger personnel and damage the product or cause it to malfunction.

- Use only original spare parts or spares authorized by SCHUNK.

2.4 Gripper fingers

Requirements of gripper fingers

Accumulated energy can make the product unsafe and risk the danger of serious injuries and considerable material damage.

- Execute the gripper fingers in such a way that the product reaches either the "open" or "closed" position in a de-energized state.
- Only change gripper fingers if no residual energy can be released.
- Make sure that the product and the top jaws are a sufficient size for the application.

2.5 Ambient conditions and operating conditions

Required ambient conditions and operating conditions

Incorrect ambient and operating conditions can make the product unsafe, leading to the risk of serious injuries, considerable material damage and/or a significant reduction to the product's life span.

- Make sure that the product is used only in the context of its defined application parameters, ▶ 3 [16].

2.6 Personnel qualification

Inadequate qualifications of the personnel

If the personnel working with the product is not sufficiently qualified, the result may be serious injuries and significant property damage.

- All work may only be performed by qualified personnel.
- Before working with the product, the personnel must have read and understood the complete assembly and operating manual.
- Observe the national safety regulations and rules and general safety instructions.

The following personal qualifications are necessary for the various activities related to the product:

Trained electrician

Due to their technical training, knowledge and experience, trained electricians are able to work on electrical systems, recognize and avoid possible dangers and know the relevant standards and regulations.

Qualified personnel

Due to its technical training, knowledge and experience, qualified personnel is able to perform the delegated tasks, recognize and avoid possible dangers and knows the relevant standards and regulations.

Instructed person

Instructed persons were instructed by the operator about the delegated tasks and possible dangers due to improper behaviour.

Service personnel of the manufacturer

Due to its technical training, knowledge and experience, service personnel of the manufacturer is able to perform the delegated tasks and to recognize and avoid possible dangers.

2.7 Personal protective equipment

Use of personal protective equipment

Personal protective equipment serves to protect staff against danger which may interfere with their health or safety at work.

- When working on and with the product, observe the occupational health and safety regulations and wear the required personal protective equipment.
- Observe the valid safety and accident prevention regulations.
- Wear protective gloves to guard against sharp edges and corners or rough surfaces.
- Wear heat-resistant protective gloves when handling hot surfaces.
- Wear protective gloves and safety goggles when handling hazardous substances.
- Wear close-fitting protective clothing and also wear long hair in a hairnet when dealing with moving components.

2.8 Notes on safe operation

Incorrect handling of the personnel

Incorrect handling and assembly may impair the product's safety and cause serious injuries and considerable material damage.

- Avoid any manner of working that may interfere with the function and operational safety of the product.
- Use the product as intended.
- Observe the safety notes and assembly instructions.
- Do not expose the product to any corrosive media. This does not apply to products that are designed for special environments.
- Eliminate any malfunction immediately.
- Observe the care and maintenance instructions.
- Observe the current safety, accident prevention and environmental protection regulations regarding the product's application field.

2.9 Transport

Handling during transport

Incorrect handling during transport may impair the product's safety and cause serious injuries and considerable material damage.

- When handling heavy weights, use lifting equipment to lift the product and transport it by appropriate means.
- Secure the product against falling during transportation and handling.
- Stand clear of suspended loads.

2.10 Malfunctions

Behavior in case of malfunctions

- Immediately remove the product from operation and report the malfunction to the responsible departments/persons.
- Order appropriately trained personnel to rectify the malfunction.
- Do not recommission the product until the malfunction has been rectified.
- Test the product after a malfunction to establish whether it still functions properly and no increased risks have arisen.

2.11 Disposal

Handling of disposal

The incorrect handling of disposal may impair the product's safety and cause serious injuries as well as considerable material and environmental harm.

- Follow local regulations on dispatching product components for recycling or proper disposal.

2.12 Fundamental dangers

General

- Observe safety distances.
- Never deactivate safety devices.
- Before commissioning the product, take appropriate protective measures to secure the danger zone.
- Disconnect power sources before installation, modification, maintenance, or calibration. Ensure that no residual energy remains in the system.
- If the energy supply is connected, do not move any parts by hand.
- Do not reach into the open mechanism or movement area of the product during operation.

2.12.1 Protection during handling and assembly

Incorrect handling and assembly

Incorrect handling and assembly may impair the product's safety and cause serious injuries and considerable material damage.

- Have all work carried out by appropriately qualified personnel.
- For all work, secure the product against accidental operation.
- Observe the relevant accident prevention rules.
- Use suitable assembly and transport equipment and take precautions to prevent jamming and crushing.

Incorrect lifting of loads

Falling loads may cause serious injuries and even death.

- Stand clear of suspended loads and do not step into their swiveling range.
- Never move loads without supervision.
- Do not leave suspended loads unattended.

2.12.2 Protection during commissioning and operation

Falling or violently ejected components

Falling and violently ejected components can cause serious injuries and even death.

- Take appropriate protective measures to secure the danger zone.
- Never step into the danger zone during operation.

2.12.3 Protection against dangerous movements

Unexpected movements

Residual energy in the system may cause serious injuries while working with the product.

- Switch off the energy supply, ensure that no residual energy remains and secure against inadvertent reactivation.
- Never rely solely on the response of the monitoring function to avert danger. Until the installed monitors become effective, it must be assumed that the drive movement is faulty, with its action being dependent on the control unit and the current operating condition of the drive. Perform maintenance work, modifications, and attachments outside the danger zone defined by the movement range.
- To avoid accidents and/or material damage, human access to the movement range of the machine must be restricted. Limit/prevent accidental access for people in this area due through technical safety measures. The protective cover and protective

fence must be rigid enough to withstand the maximum possible movement energy. EMERGENCY STOP switches must be easily and quickly accessible. Before starting up the machine or automated system, check that the EMERGENCY STOP system is working. Prevent operation of the machine if this protective equipment does not function correctly.

2.12.4 Protection against electric shock

Possible electrostatic energy

Components or assembly groups may become electrostatically charged. When the electrostatic charge is touched, the discharge may trigger a shock reaction leading to injuries.

- The operator must ensure that all components and assembly groups are included in the local potential equalisation in accordance with the applicable regulations.
- While paying attention to the actual conditions of the working environment, the potential equalisation must be implemented by a specialist electrician according to the applicable regulations.
- The effectiveness of the potential equalisation must be verified by executing regular safety measurements.

2.13 Notes on particular risks



⚠ DANGER

Risk of fatal injury from suspended loads!

Falling loads can cause serious injuries and even death.

- Stand clear of suspended loads and do not step within their swiveling range.
- Never move loads without supervision.
- Do not leave suspended loads unattended.
- Wear suitable protective equipment.



⚠ WARNING

Risk of injury from objects falling and being ejected!

Falling and ejected objects during operation can lead to serious injury or death.

- Take appropriate protective measures to secure the danger zone.



⚠ WARNING

Risk of injury from sharp edges and corners!

Sharp edges and corners can cause cuts.

- Use suitable protective equipment.



⚠ WARNING

Risk of injury due to unexpected movements!

If the power supply is switched on or residual energy remains in the system, components can move unexpectedly and cause serious injuries.

- Before starting any work on the product: Switch off the power supply and secure against restarting.
- Make sure, that no residual energy remains in the system.



⚠ WARNING

Risk of injury from crushing and impacts!

Serious injury could occur during movement of the base jaw, due to breakage or loosening of the gripper fingers or if the workpiece is lost.

- Wear suitable protective equipment.
- Do not reach into the open mechanism or the movement area of the product.



⚠ WARNING

Risk of injury due to spring forces!

Parts are under spring tension on products which clamp using spring force or which have gripping force maintenance. While disassembling components can move unexpectedly and cause serious injuries.

- Disassemble the product cautiously.
- Make sure that no residual energy remains in the system.



⚠ WARNING

Risk of injury from objects falling during energy supply failure

Products with a mechanical gripping force maintenance can, during energy supply failure, still move independently in the direction specified by the mechanical gripping force maintenance.

- Secure the end positions of the product with SCHUNK SDV-P pressure maintenance valves.

3 Technical data

Designation	Value
Pressure medium	Compressed air, compressed air quality according to ISO 8573-1:2010 [7:4:4]
Nominal operating pressure [bar]	6
Minimum pressure [bar] without maintenance of gripping force	2
Minimum pressure [bar] with maintenance of gripping force	4
Max. pressure [bar] without maintenance of gripping force	8
Max. pressure [bar] with maintenance of gripping force	6.5
Pressure range for air purge [bar]	0.5 – 1

Ambient conditions and operating conditions

Designation	Value
Ambient temperature [°C]	
min.	+5
max.	+90
Protection class IP *	40
Noise emission [dB(A)]	≤70

* For use in dirty ambient conditions (e.g. sprayed water, vapors, abrasion or processing dust) SCHUNK offers corresponding product options as standard. SCHUNK also offers customized solutions for special applications in dirty ambient conditions.

More technical data is included in the catalog data sheet. Whichever is the latest version.

4 Design and description

4.1 Design

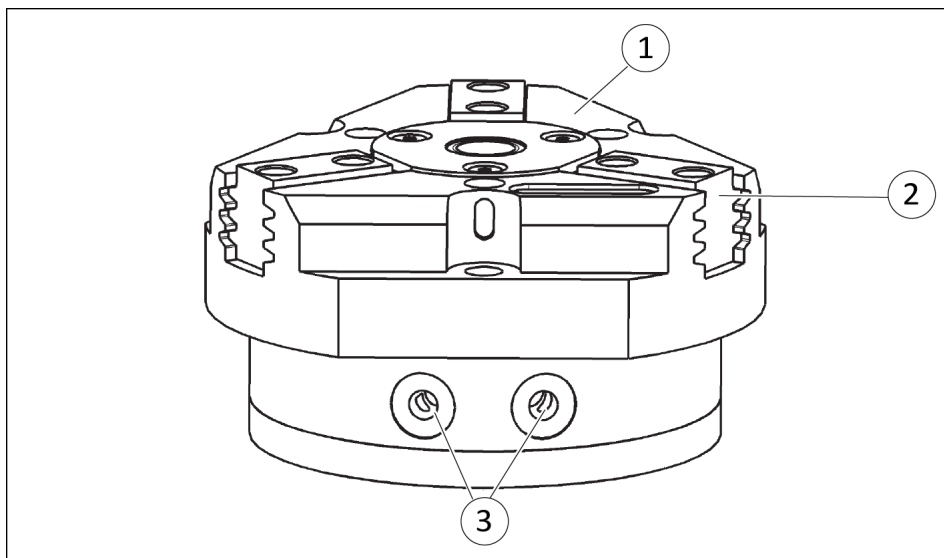

- | | |
|---|--------------------------------|
| 1 | Case |
| 2 | Base jaw |
| 3 | Main compressed air connection |

4.2 Description

Universal 3-finger centric gripper with high gripping force and high maximum moments per finger, plus center bore.

5 Assembly

5.1 Installing and connecting



⚠ WARNING

Risk of injury due to unexpected movements!

If the power supply is switched on or residual energy remains in the system, components can move unexpectedly and cause serious injuries.

- Before starting any work on the product: Switch off the power supply and secure against restarting.
- Make sure, that no residual energy remains in the system.

CAUTION

Damage to the gripper is possible!

If the maximum permissible finger weight or the permissible mass moment of inertia of the fingers is exceeded, the gripper can be damaged.

- A jaw movement always has to be without jerks and bounce.
- You must therefore implement sufficient reduction and/or damping.
- Observe the information in the catalog data sheet.

1. Check the evenness of the mounting surface, ▶ 5.2.1 [☐ 20].
2. Only open the required air connections (main connection or direct connection), ▶ 5.2.2 [☐ 23].
3. Connect the product via the hose-free direct connection.
 - ⇒ Use O-rings from the accessory pack.
 - ⇒ Seal main air connections which are not required with locking screws.
4. OR: Connect compressed air lines to the main air connections "A" and "B".
 - ⇒ Screw in air connections (plug connections).
OR: Screw on throttle valve in order to be able to perform sufficient throttling and/or damping.
5. Screw the product to the machine/system, ▶ 5.2.1 [☐ 20].
 - ⇒ When mounting from the rear: use cylindrical pins for fixing the product in place.
 - ⇒ If necessary, use appropriate connection elements (adapter plates).
 - ⇒ Observe requirements for adapter plate, ▶ 5.2.1 [☐ 20].

- ⇒ Observe the maximal tightening torque, admissible screw-in depth and, if necessary, strength class.
- 6.** Secure the gripper fingers to the base jaws, ▶ [5.2.1 \[20\]](#).
 - ⇒ Use centering sleeves from the enclosed accessory pack.
- 7.** If necessary, mount the pressure piece for spring-supported positioning of the work piece against a stop, ▶ [5.2.1.1 \[22\]](#).
- 8.** Connect the sensor, see assembly and operating manual of the sensor.
- 9.** Mount the sensor, ▶ [5.3 \[25\]](#).

5.2 Connections

5.2.1 Mechanical connection

Evenness of the mounting surface

The values apply to the whole mounting surface to which the product is mounted.

Edge length	Permissible unevenness
< 100	< 0.02
> 100	< 0.05

Tab.: Requirements for evenness of the mounting surface (Dimensions in mm)

Requirements for customer adapter plates

If the adapter plate has bores or recesses and therefore the product is not fully flush, the minimum support surface must be adhered to. The recess/bore in the adapter plate may not exceed the dimension "A"; for dimensions, see the following table.

The product can be assembled from two sides.

Connections at the housing and on the base jaws

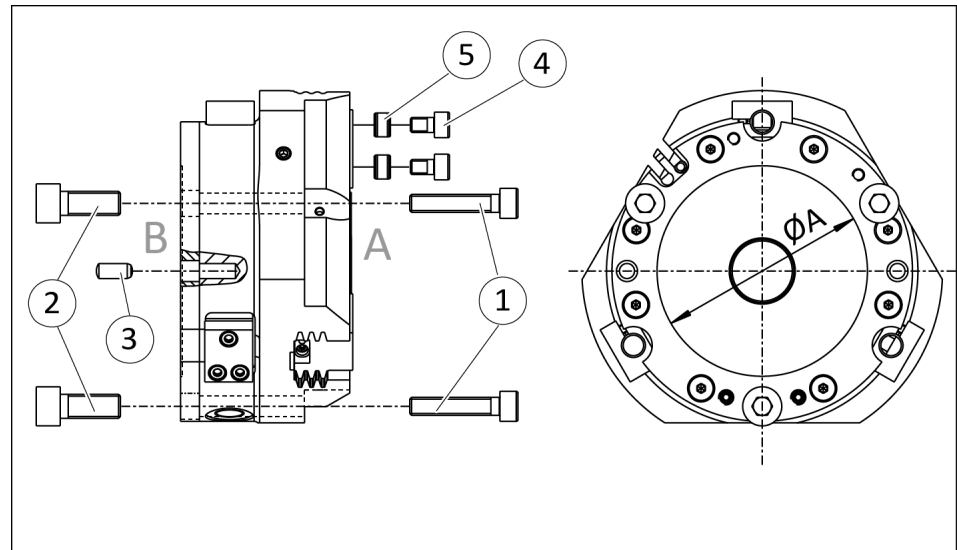

Assembly options

Connection on side A

Size	① Screw (3x)	③ Centering pin** Ø [mm]
50	M3	3
64	M5	4
80	M6	5
100	M6	5
125	M8	6
160	M8	6
200	M10	8
240	M12	8
300	M16	10

Connection on side B

Size	② Screw* (3x)	③ Centering pin** ∅ [mm]	Recess (A) ∅ [mm]
50	M4/10	3	32
50 AS	M4/20	3	32
50 IS	M4/20	3	32
64	M6/14	4	40
64 AS	M6/26	4	40
64 IS	M6/26	4	40
80	M8/16	5	55
80 AS	M8/32	5	55
80 IS	M8/32	5	55
100	M8/18	5	70
100 AS	M8/38	5	70
100 IS	M8/38	5	70
125	M8/18	6	85
125 AS	M8/45	6	85
125 IS	M8/45	6	85
160	M10/18	6	115
160 AS	M10/46	6	115
160 IS	M10/46	6	115
200	M12/25	8	150
200 AS	M12/60	8	150
200 IS	M12/60	8	150
240	-	8	196
240 AS	-	8	196
240 IS	-	8	196
300	-	10	236
300 O.D.	-	10	236
300 I.D.	-	10	236

* Max. depth of engagement from locating surface [mm]

** Contained in accessory pack.

Connections on the base jaws

Size	④ Screw* (2x)	⑤ Centering sleeve** diameter [mm]
50	2.5/6	4
64	M3/8	5
80	M4/10	6
100	M5/10	8
125	M6/13	10
160	M6/13	10
200	M12/16	16
240	M12/20	16
300	M16/28	22

* Max. depth of engagement from locating surface [mm]

** Contained in accessory pack.

5.2.1.1 Mounting of the gripper by using a spring loaded pressure-piece



⚠ CAUTION

The spring-loaded pressure piece is under spring tension.

The pressure piece can fly out in an uncontrolled fashion and cause contusions.

- During assembly or disassembly, be especially careful with the springs.

When mounting the gripper from the side of the gripper fingers, the assembly of the pressure piece must be done **after** the mounting of the gripper.

Mounting the pressure piece is described in the insert "Installation instructions - pressure piece", which is included in the pressure piece's scope of delivery.

5.2.2 Pneumatic connection

NOTE

- Observe the requirements for the compressed air supply, ▶ 3 [16].
- In case of compressed air loss (cutting off the energy line), the components lose their dynamic effects and do not remain in a secure position. However, the use of a SDV-P pressure maintenance valve is recommended in this case in order to maintain the dynamic effect for some time. Product variants are also offered with mechanical gripping force via springs, which also ensure a minimum clamping force in the event of a pressure drop.

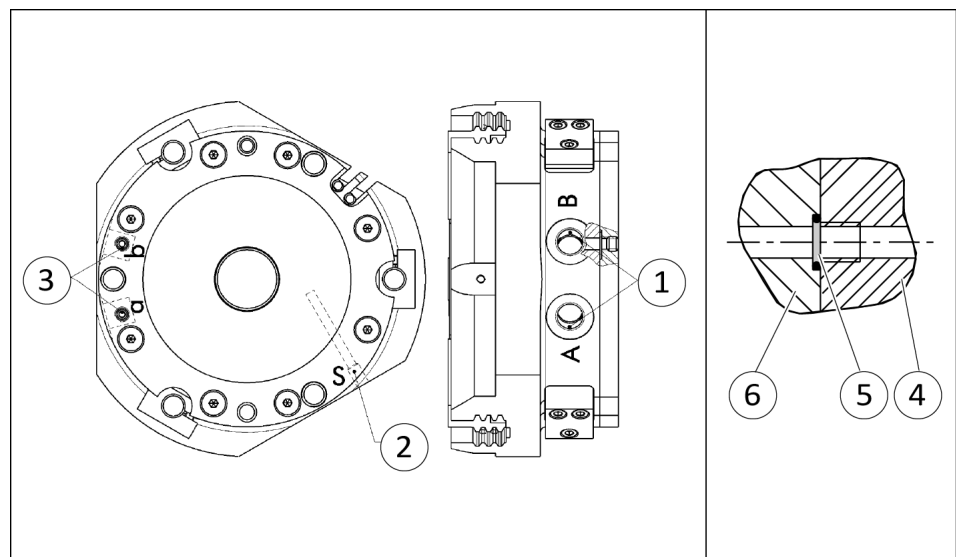

Air connections

1	Main connections (Hose connection) (A = open, B = close)
2	Air purge connection
3	Hose-free direct connection (a = open, b = close)

Hose-free direct connection					
4	Product	5	O-ring	6	Attachment

Size	Main air connections	Hose-free direct connection	Air purge connection
50	2x M5	2x M3	M5
64	2x M5	2 x M4	M5
80	2x M5	2 x M4	M5

Size	Main air connections	Hose-free direct connection	Air purge connection
100	2x G1/8"	2 x M5	M5
125	2x G1/8"	2 x M5	M5
160	2x G1/8"	2 x M4	M5
200	2x G1/8"	2 x M5	M5
240	2x G1/4"	2 x M5	M5
300	2x G1/4"	2 x M8	M5

Tab.: Thread diameter of the air connections

5.3 Mounting the sensor

NOTE

Observe the assembly and operating manual of the sensor for mounting and connecting.

The product is prepared for the use of sensors.

- For the exact type designations of suitable sensors, please see catalog datasheet and ▶ 5.3.1 [25].
- For technical data for the suitable sensors, see assembly and operating manual and catalog datasheet.
 - The assembly and operating manual and catalog datasheet are included in the scope of delivery for the sensors and are available at schunk.com.
- Information on handling sensors is available at schunk.com or from SCHUNK contact persons.

5.3.1 Overview of sensors

Size	MMS 22	MMS 22-PI1	MMS 22-PI2	MMS-P 22	MMS 22-IOL	RMS 80	IN 80	FPS-S M8	APS-M1	APS-Z80	RSS R1/T2 / RMS 80
50	✓	✓	✓	✓	⊘	⊘	⊘	⊘	⊘	⊘	⊘
64	✓	✓	✓	✓	✓*	⊘	⊘	⊘	⊘	⊘	⊘
64	✓	✓	✓	✓	✓	⊘	⊘	⊘	⊘	⊘	⊘
64	✓	✓	✓	✓	⊘	⊘	⊘	⊘	⊘	⊘	⊘
80	✓	✓	✓	✓	✓*	✓	✓	✓	✓	✓	⊘
80	✓	✓	✓	✓	✓	✓	✓	✓	✓	✓	⊘
GKS80	✓	✓	✓	✓	⊘	✓	✓	✓	✓	✓	⊘
100	✓	✓	✓	✓	✓	✓	✓	✓	✓	✓	✓
125	✓	✓	✓	✓	✓	✓	✓	✓	✓	✓	✓
160	✓	✓	✓	✓	✓	✓	✓	✓	✓	✓	✓
200	✓	✓	✓	✓	⊘	✓	✓	✓	✓	✓	✓
240	✓	✓	⊘	⊘	⊘	✓	✓	✓	✓	✓	⊘
300	✓	✓	⊘	⊘	⊘	✓	✓	✓	✓	✓	✓

* only available with the following variants:

PZB-plus 64-1 / PZB-plus 64-2

PZB-plus 80-1-AS / PZB-plus 80-2-AS / PZB-plus 80-1-IS / PZB-plus 80-2-IS

5.3.2 Switch-off hysteresis for magnetic switches

Sensors MMS 22, MMS 22-PI1, MMS 22-PI2 and MMS-P 22

The smallest detectable difference in stroke is defined in the following table:

For products with X mm nominal stroke per jaw	Min. query range per jaw/ min. queried stroke difference per jaw
$X \leq 5 \text{ mm}$	30 % of the nominal stroke per jaw
$X > 5 \text{ mm to } X \leq 10 \text{ mm}$	20 % of the nominal stroke per jaw
$X > 10 \text{ mm}$	10 % of the nominal stroke per jaw

Tab.: The smallest detectable difference in stroke based on the nominal stroke

Example: Product with 7 mm nominal stroke per jaw

$$7 \text{ mm} * 20\% = 1.4 \text{ mm}$$

5.3.3 Turn control cam

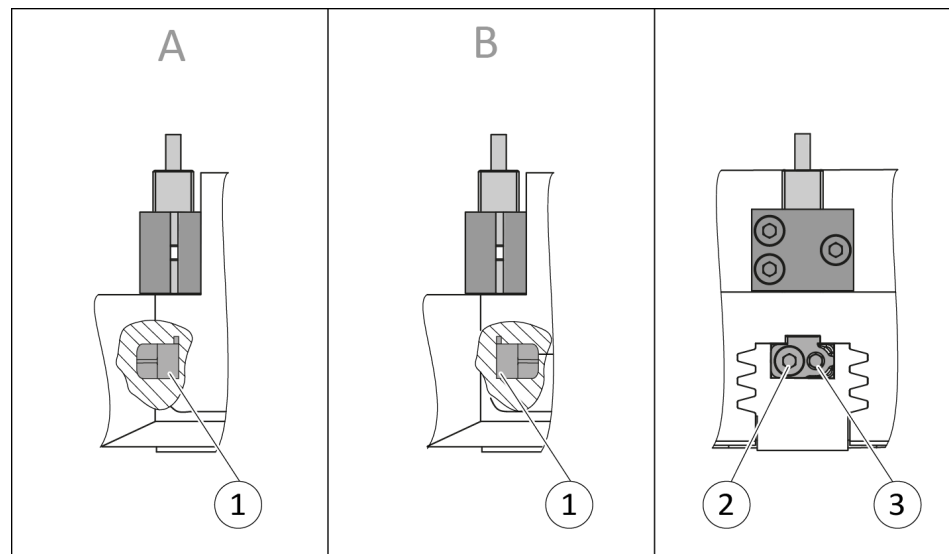

Turn control cam, example control cam for inductive monitoring

Depending on the jaw stroke, it may be necessary to change the alignment of the control cam for the sensors IN 80 and RMS 80.

In the image, the installation situation (A) shows the control cam in the delivery state of the product and the installation situation (B) shows the turned control cam.

In order to change the alignment of the control cam, proceed as follows:

1. Undo the screw (2).
2. Remove control cam (1) from the product, turn and re-insert it into the product.
3. Turn the screw (3) to push the position of the control cam (1).

5.3.4 Setting dimensions

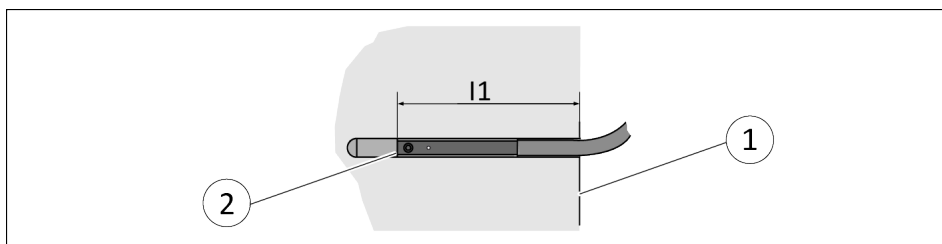

* Setting dimension l_1 , from product bottom edge (1) to front sensor (2)

The setting dimension applies for the following sensors:

- Programmable magnetic switch MMS 22-PI1
- Programmable magnetic switch MMS 22-PI2
- Programmable magnetic switch MMS-P 22

Size	l_1^* [mm]
50	24.3
50 AS	34.3
50 IS	34.0
64	26.3
64 AS	39.8
64 IS	39.1
80	29.5
80 AS	44.7
80 IS	44.2
100	32.6
100 AS	53.6
100 IS	52.6
125	34.5
125 AS	60.9
125 IS	60.9
160	40.1
160 AS	67.4
160 IS	67.6
200	42.6
200 AS	79.9
200 IS	78.6

Tab.: Setting dimensions

5.3.5 Mounting MMS 22 magnetic switch

CAUTION

Risk of damage to the sensor during assembly!

- Observe the maximal tightening torque.

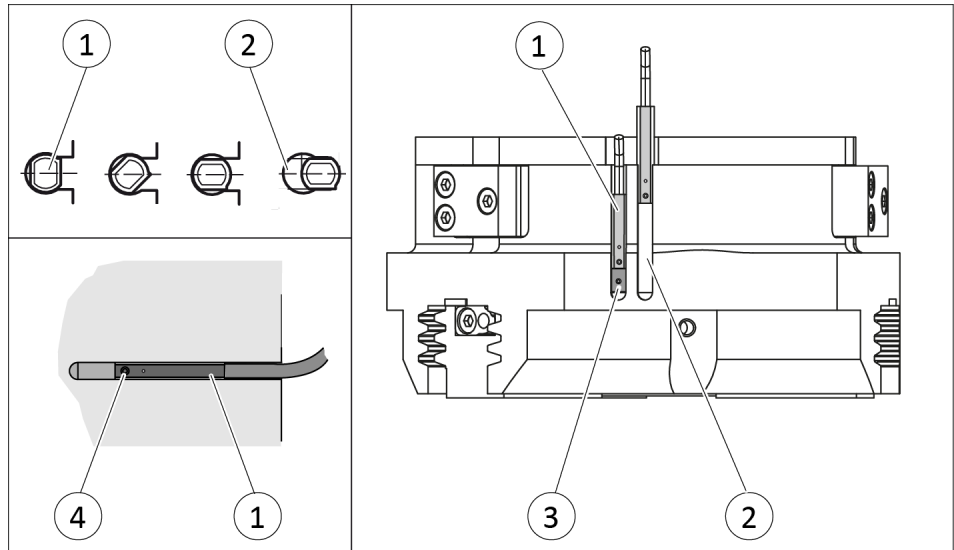

Positioning the magnetic switches

Position "Gripper open" or "Part gripped (I.D. gripping)"

1. Bring product in the position to be set.
2. If necessary remove T-nut (3).
3. Turn the sensor 1 (1) into the groove (2).
OR: Slide the sensor 1 (1) into the groove (2) until the sensor 1 (1) stops at the end of the groove.
4. Pull the sensor 1 (1) back again slowly until it switches.
5. Secure the sensor 1 (1) using the set-screw (4).
Tightening torque: 10 Ncm
6. Bring product into the "Gripper open" or "Part gripped" position and test the function.

Position "Gripper closed" or "Part gripped (O.D. gripping)"

1. Bring product in the position in which it is to be set.
2. If necessary remove T-nut (3).
3. Turn the sensor 2 (1) into the groove (2).
OR: Slide sensor 2 (1) into the groove (2) in the direction of the housing middle (3), until the sensor 2 (1) switches.
4. Secure the sensor 2 (1) using the set-screw (4).
Tightening torque: 10 Ncm
5. Bring product into the "Gripper closed" or "Part gripped" position and test the function.

5.3.6 Mounting MMS 22-PI1 programmable magnetic switch

CAUTION

Risk of damage to the sensor during assembly!

- Observe the maximal tightening torque.

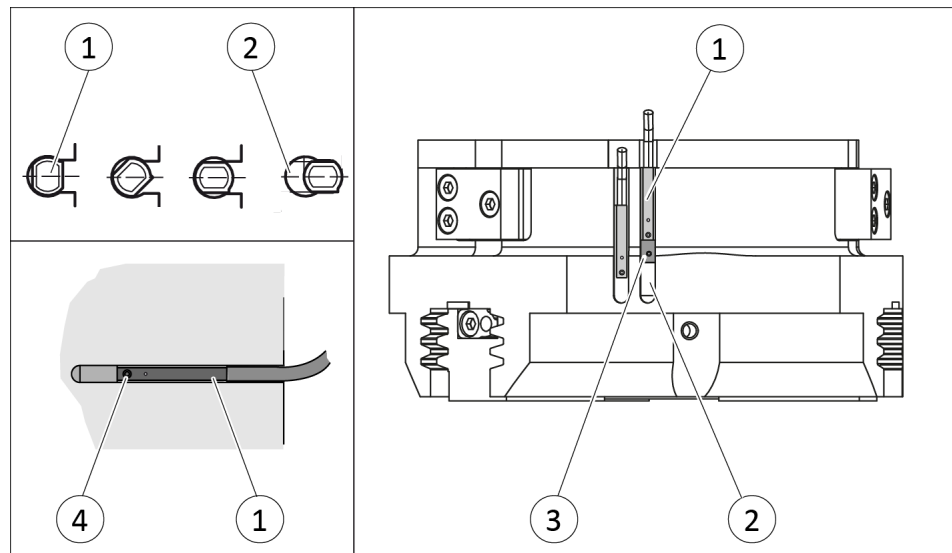

NOTE

If there is no T-nut available, slide the sensor according to dimension l1 into the groove (2), ▶ 5.3.4 [27].

Size 50 – 160

1. Turn the sensor 1 (1) into the groove (2).
OR: Slide the sensor 1 (1) into the groove (2) until the sensor 1 (1) stops at the T-nut (3).
2. Secure the sensor 1 (1) using the set-screw (4).
Tightening torque: 10 Ncm
3. Adjust sensor 1 (1), see sensor assembly and operating manual.
4. Repeat steps for sensor 2.

Size 200 – 300

1. Put product in the position in which it is to be set.
2. Hold teaching tool to the sensor 1 (1) until the sensor flashes.
3. Slide sensor 1 (1) into the groove (2), until the sensor 1 flashes rapidly.
⇒ The optimum position is displayed.
4. Secure the sensor 1 (1) using the set-screw (3).
Tightening torque: 10 Ncm
5. Hold teaching tool to the sensor 1 (1) to confirm the position.
⇒ The sensor 1 (1) has been taught in.
6. Repeat steps for sensor 2.

5.3.7 Mounting programmable MMS 22-PI2 magnetic switch

CAUTION

Risk of damage to the sensor during assembly!

- Observe the maximal tightening torque.

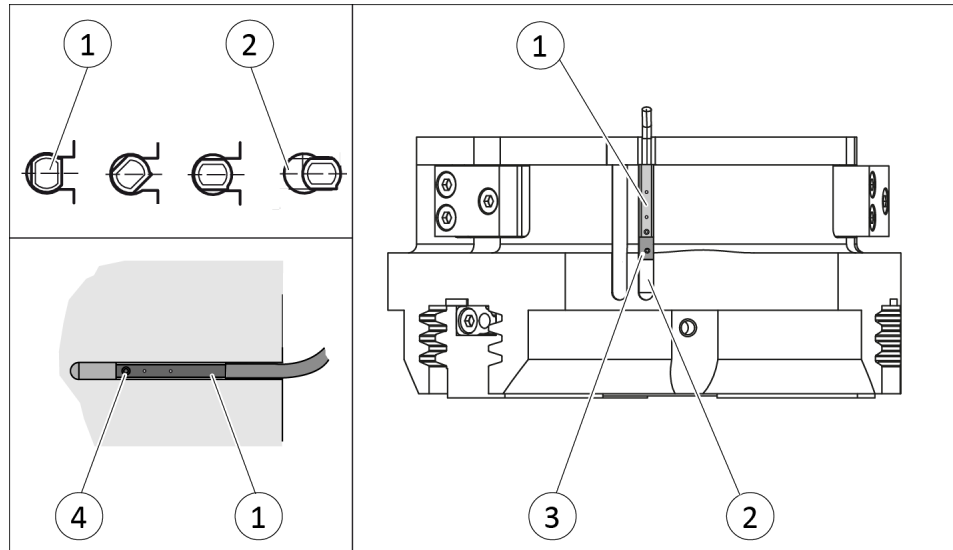

NOTE

If there is no T-nut available, slide the sensor according to dimension l1 into the groove (2), ► 5.3.4 [27].

1. Turn the sensor (1) into the groove (2).
OR: Slide the sensor (1) into the groove (2) until the sensor (1) stops at the T-nut (3).
2. Secure the sensor (1) using the set-screw (4).
Tightening torque: 10 Ncm
3. Adjust sensor (1), see sensor assembly and operating manual.

5.3.8 Mounting programmable MMS-P 22 magnetic switch

CAUTION

Risk of damage to the sensor during assembly!

- Observe the maximal tightening torque.

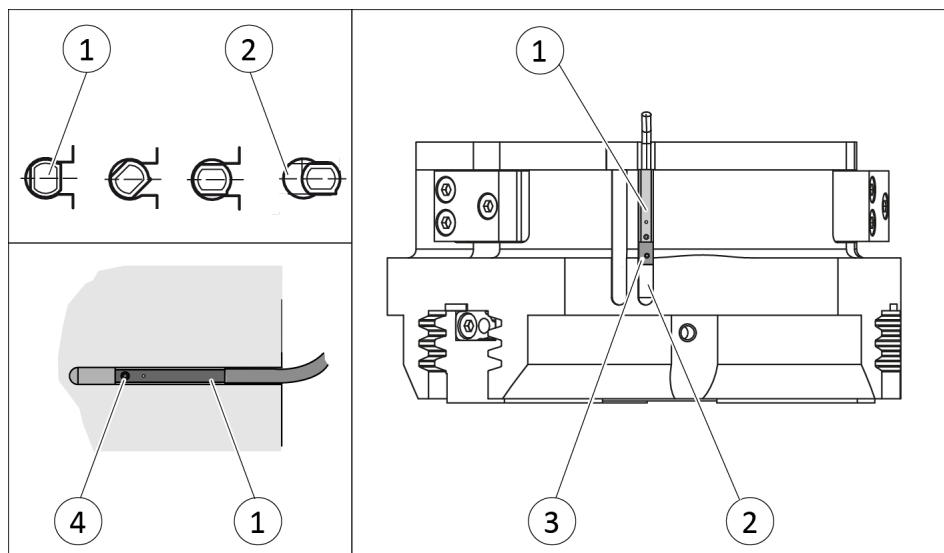

NOTE

If there is no T-nut available, slide the sensor according to dimension l1 into the groove (2), ► 5.3.4 [27].

1. Turn the sensor (1) into the groove (2).
OR: Slide the sensor (1) into the groove (2) until the sensor (1) stops at the T-nut (3).
2. Secure the sensor (1) using the set-screw (4).
Tightening torque: 10 Ncm
3. Adjust sensor (1), see sensor assembly and operating manual.

5.3.9 Mounting programmable magnetic switch MMS-IOL

NOTE

This sensor can only be used in size 64 for grippers without gripping force maintenance.

NOTE

This sensor can only be used in size 80 for grippers with gripping force maintenance.

CAUTION

Risk of damage to the sensor during assembly!

- Observe the maximal tightening torque.

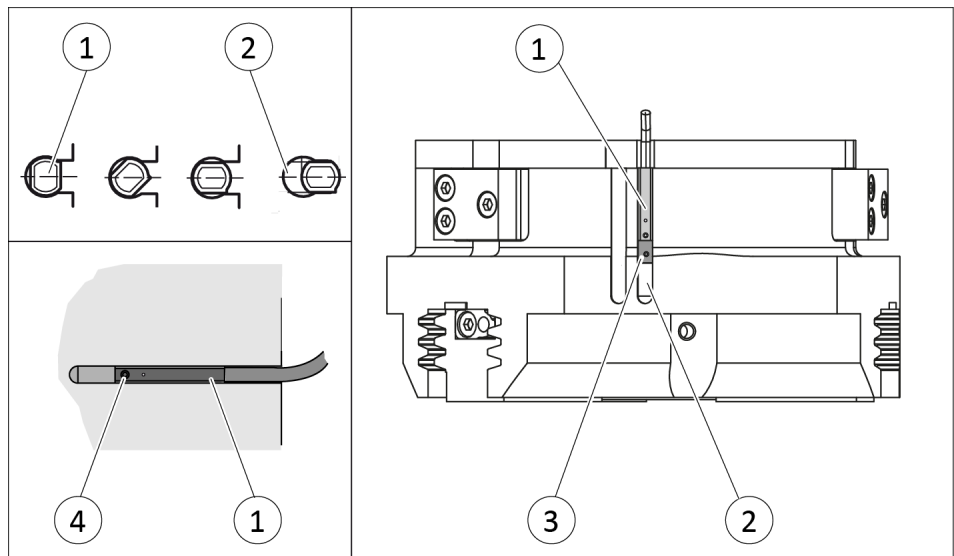

NOTE

If there is no T-nut available, slide the sensor according to dimension l1 into the groove (2), see following table.

1. Turn the sensor (1) into the groove (2).
OR: Slide the sensor (1) into the groove (2) until the sensor (1) stops at the T-nut (3).
2. Secure the sensor (1) using the set-screw (4).
Tightening torque: 10 Ncm
3. Adjust sensor (1), see sensor assembly and operating manual.

Size	l1* [mm]	Size	l1* [mm]
64	27.0	125	36.0
80 IS	47.0	125 IS	62.5
80 AS	47.5	125 AS	64.0

Size	l1* [mm]	Size	l1* [mm]
100	34.5	160	42.0
100 IS	56.5	160 IS	73.0
100 AS	56.5	160 AS	74.0

Tab.: Dimensions l1

* Dimen Bottom edge of the product to front edge of the sensor
sion l1

Size 160-1 / 160-1 IS:

During the monitoring process, the first and last 15% of the nominal stroke will not produce a change in the analog signal. It is therefore not possible to monitor the end positions. Should you have questions, do not hesitate to contact SCHUNK.

Size	Stroke 1	
	100 %	15 %
160-1	13 mm	1.95 mm
160-1 IS	13 mm	1.95 mm

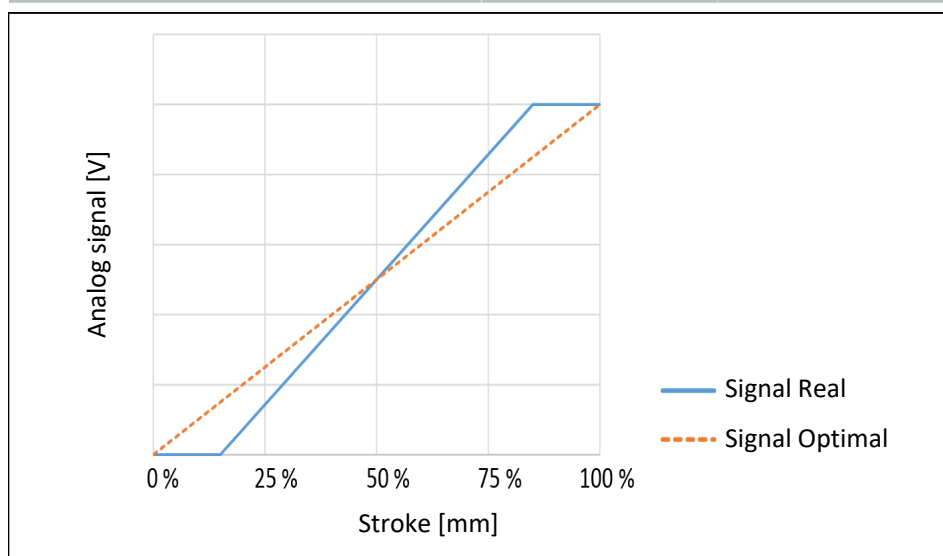

5.3.10 Mounting the reed switch RMS 80

CAUTION

Blockade of the gripper after setting or replacing of the switching cam!

The switching cam can be tilt in the guide, if it was not fixed exactly in the base jaw.

- Apply the switching cam in the direction of the base jaw, so that the cam does not contact the housing of the gripper.

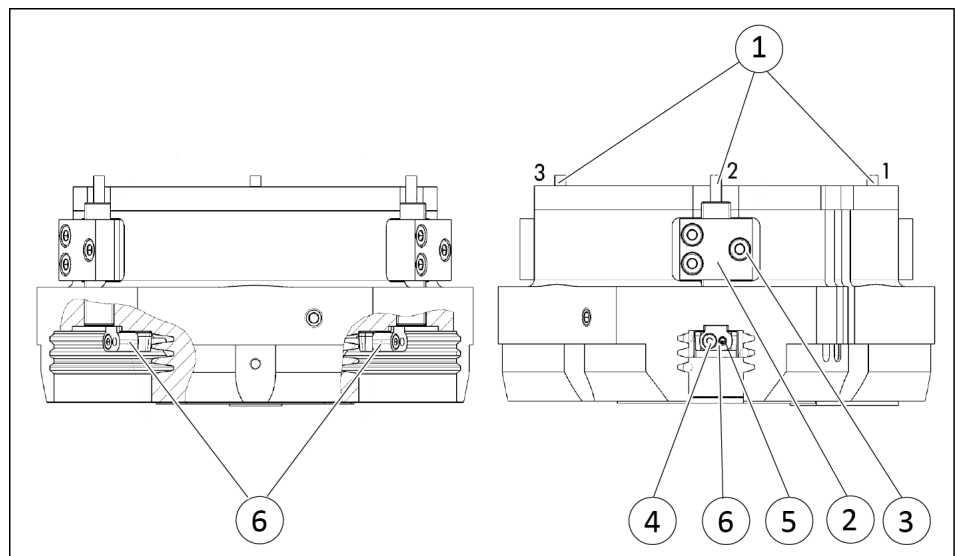

Position "Gripper open" or "Part gripped (I.D. gripping)"

1. Slide the sensor 1 (1) or sensor 2 (1) to the stop into the bracket (2).
2. Tighten the screw (3) on the bracket (2).
Tightening torque: 0.2 Nm
3. Open gripper or grip part.
4. Undo the screw (4).
5. Turn the screw (5) to push the position of the control cam (6).
⇒ Slide control cam (6) inwards until the sensor 1 (1) no longer responds.
Move the control cam (6) back towards the outside until the sensor 1 (1) begins to switch.
6. Tighten screw (4) and in doing so press the control cam in the direction of the gripper fingers. **IMPORTANT! The control cam may tilt in the guide if it has not been tightened properly.**
⇒ Switching point is set.
7. Bring product into the "Gripper open" or "Part gripped" position and test the function.

NOTE

If the switching position cannot be queried, it may be that the alignment of the control cam has to be changed, ▶ 5.3.3 [26].

Position "Gripper closed" or "Part gripped (O.D. gripping)"

1. Slide the sensor 3 (1) to the stop into the bracket (2).
2. Tighten the screw (3) on the bracket (2).
Tightening torque: 0.2 Nm
3. Close gripper or grip part.
4. Undo the screw (4).
5. Turn the screw (5) to push the position of the control cam (6).
⇒ Slide control cam (6) outwards until the sensor 3 (1) no longer responds.
Move the control cam (6) back towards the inside until the sensor 3 (1) begins to switch.
6. Tighten screw (4) and in doing so press the control cam in the direction of the gripper fingers. **IMPORTANT! The control cam may tilt in the guide if it has not been tightened properly.**
⇒ Switching point is set.
7. Bring product into the "Gripper closed" or "Part gripped" position and test the function.

NOTE

If the switching position cannot be queried, it may be that the alignment of the control cam has to be changed, ▶ 5.3.3 [26].

5.3.11 Mounting inductive proximity switch IN 80

CAUTION

Blockade of the gripper after setting or replacing of the switching cam!

The switching cam can be tilt in the guide, if it was not fixed exactly in the base jaw.

- Apply the switching cam in the direction of the base jaw, so that the cam does not contact the housing of the gripper.

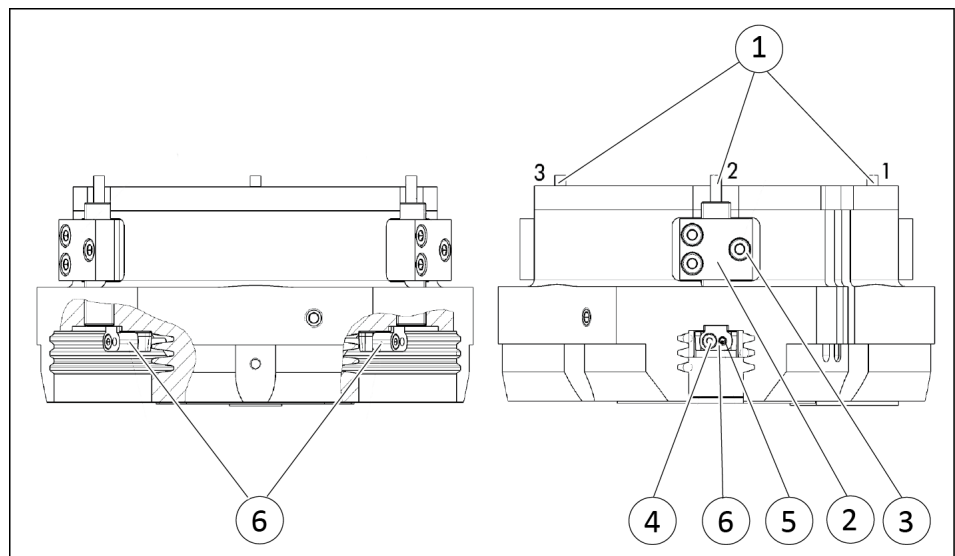

Position "Gripper open" or "Part gripped (I.D. gripping)"

1. Slide the sensor 1 (1) or sensor 2 (1) to the stop into the bracket (2).
2. Tighten the screw (3) on the bracket (2).
Tightening torque: 0.2 Nm
3. Open gripper or grip part.
4. Undo the screw (4).
5. Turn the screw (5) to push the position of the control cam (6).
⇒ Slide control cam (6) inwards until the sensor 1 (1) no longer responds.
Move the control cam (6) back towards the outside until the sensor 1 (1) begins to switch.
6. Tighten screw (4) and in doing so press the control cam in the direction of the gripper fingers. **IMPORTANT! The control cam may tilt in the guide if it has not been tightened properly.**
⇒ Switching point is set.
7. Bring product into the "Gripper open" or "Part gripped" position and test the function.

NOTE

If the switching position cannot be queried, it may be that the alignment of the control cam has to be changed, ▶ 5.3.3 [26].

Position "Gripper closed" or "Part gripped (O.D. gripping)"

1. Slide the sensor 3 (1) to the stop into the bracket (2).
2. Tighten the screw (3) on the bracket (2).
Tightening torque: 0.2 Nm
3. Close gripper or grip part.
4. Undo the screw (4).
5. Turn the screw (5) to push the position of the control cam (6).
⇒ Slide control cam (6) outwards until the sensor 3 (1) no longer responds.
Move the control cam (6) back towards the inside until the sensor 3 (1) begins to switch.
6. Tighten screw (4) and in doing so press the control cam in the direction of the gripper fingers. **IMPORTANT! The control cam may tilt in the guide if it has not been tightened properly.**
⇒ Switching point is set.
7. Bring product into the "Gripper closed" or "Part gripped" position and test the function.

NOTE

If the switching position cannot be queried, it may be that the alignment of the control cam has to be changed, ▶ 5.3.3 [26].

5.3.12 Mounting flexible position sensor FPS

The flexible position sensor FPS consists of an evaluation unit and the sensor FPS-S-M8.

CAUTION

Risk of damage to the sensor during assembly!

- Observe the maximal tightening torque.

To be able to mount the sensor, the gripper has to be retrofitted with a special mounting kit.

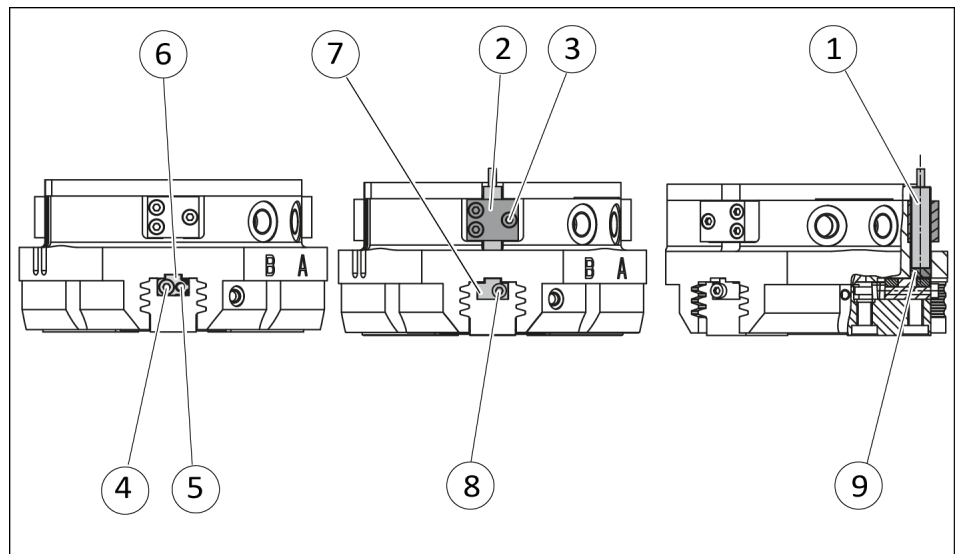

1. Move product to the "gripper open" position.
2. Loosen screw (4) and remove control cam (6) for the inductive monitoring from the base jaw.
3. Remove screw (5) from the base jaw.
4. Slide control cam (7) from the mounting kit with the recess at the front into the base jaw.
5. Screw the control cam (7) to the base jaw using the screw (8).
6. Slide spacer shim (9) into the bracket (2) to the stop.
7. Slide the sensor (1) to the stop into the bracket (2).
8. Tighten the screw (3) on the bracket (2).
Tightening torque: 0.2 Nm
9. Adjust sensor (1), see assembly and operating manual of the sensor.

5.3.13 Mounting the analog position sensor APS-M1

To be able to mount the sensor, the gripper has to be retrofitted with a special mounting kit.

CAUTION

Blockade of the gripper after setting or replacing of the switching cam!

The switching cam can be tilt in the guide, if it was not fixed exactly in the base jaw.

- Apply the switching cam in the direction of the base jaw, so that the cam does not contact the housing of the gripper.

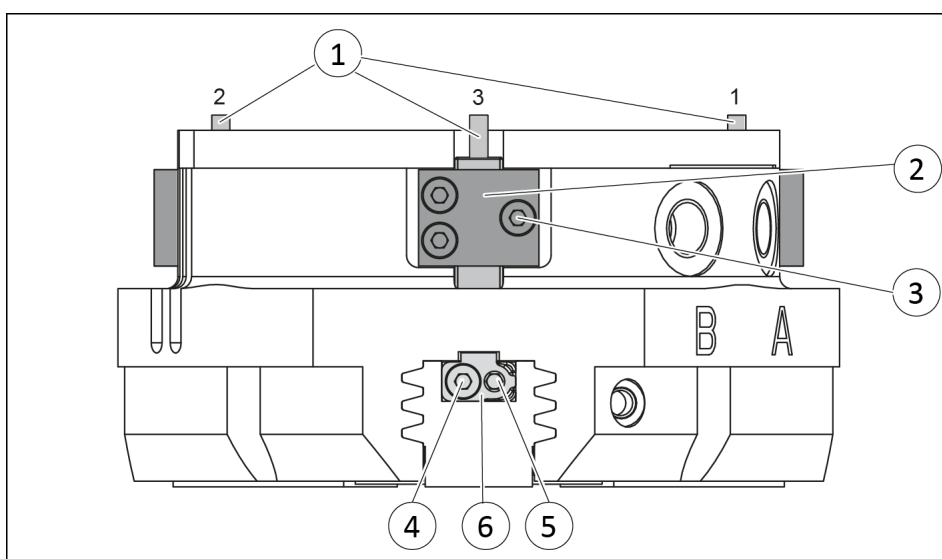

1. Move product to the "gripper open" position.
2. Loosen screw (4) and remove control cam (6) for the inductive monitoring from the base jaw.
3. Apply adhesive to the top and sides of the control cam (6) from the mounting kit.
 - ⇒ Make sure that there is no adhesive on the bottom of the control cam (6), which comes into contact with the sensor.
 - ⇒ SCHUNK recommends the adhesive Loctite 290 or 638.
4. Slide control cam (6) out of the mounting kit front into the base jaw.
 - ⇒ Ensure that the higher front side of the control cam (6) is pointing outwards.
5. Tighten screw (4) slightly.
6. Turn the screw (5) to push the position of the control cam (6).
7. Tighten screw (4) and in doing so press the control cam (6) in the direction of the gripper finger.

- 8.** Slide the sensor (1) to the stop into the bracket (2).
- 9.** Tighten the screw (3) on the bracket (2).
Tightening torque: 0.2 Nm
- 10.** Adjust sensor (1), see assembly and operating manual of the sensor.

5.3.14 Mounting the analog position sensor APS-Z80

To be able to mount the sensor, the gripper has to be retrofitted with a special mounting kit.

CAUTION

Blockade of the gripper after setting or replacing of the switching cam!

The switching cam can be tilt in the guide, if it was not fixed exactly in the base jaw.

- Apply the switching cam in the direction of the base jaw, so that the cam does not contact the housing of the gripper.

During the monitoring process, the first 8% of the nominal stroke will not produce a change in the analog signal. With O.D. gripping the "Gripper closed" position and with I.D. gripping the "Gripper opened" position cannot be queried. Should you have questions, do not hesitate to contact SCHUNK.

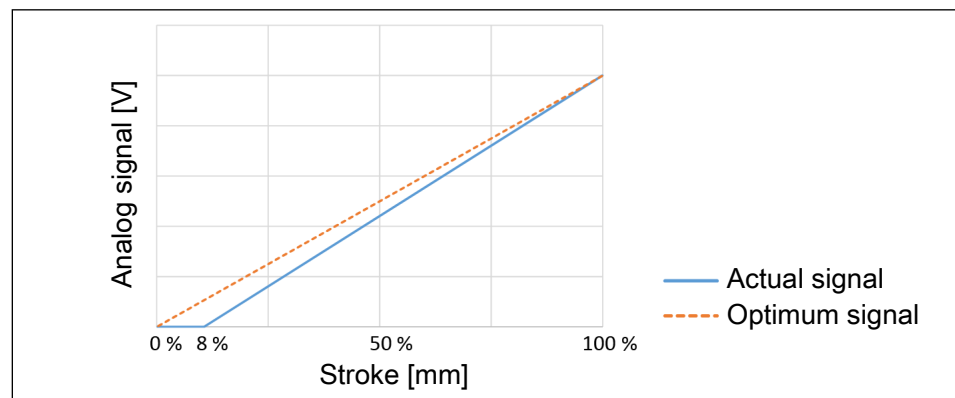

Analog signal on O.D. gripping

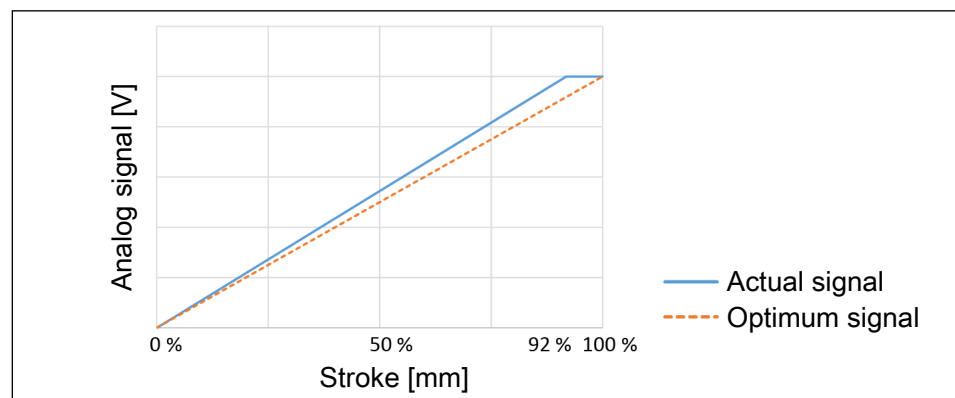

Analog signal on I.D. gripping

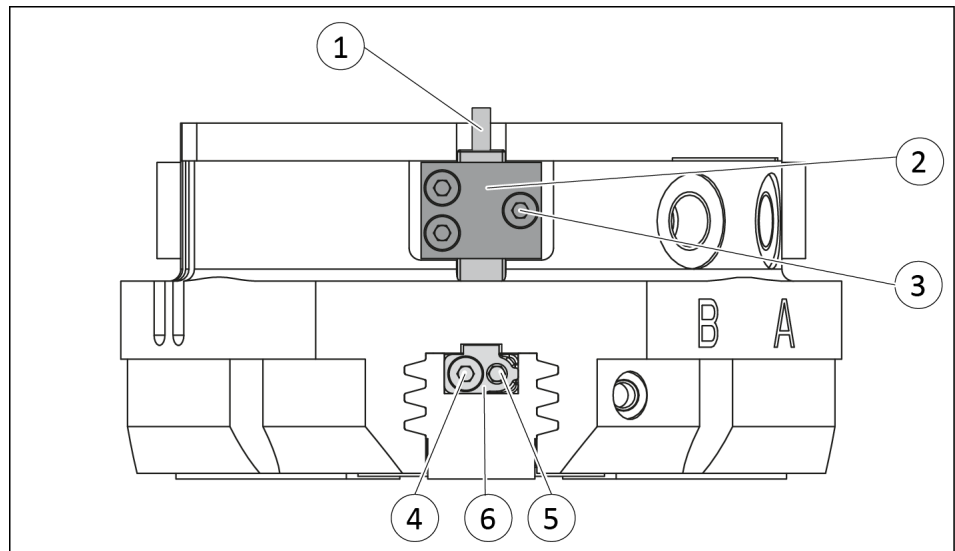

1. Move product to the "grripper open" position.
2. Loosen screw (4) and remove control cam (6) for the inductive monitoring from the base jaw.
3. Remove screw (5) from the base jaw.
4. Apply adhesive to the top and sides of the control cam (6) from the mounting kit.
 - ⇒ Make sure that there is no adhesive on the bottom of the control cam (6), which comes into contact with the sensor.
 - ⇒ SCHUNK recommends the adhesive Loctite 290 or 638.
5. Slide control cam (6) into the base jaw to the stop.
 - ⇒ Ensure that the higher front side of the control cam (6) is pointing outwards.
6. **IMPORTANT! The control cam (6) must no longer move after it is screwed on.**
 Screw the control cam (6) to the base jaw using the screw (5).
 - ⇒ Secure the screw (5) with medium-strength locking liquid.
7. Slide the sensor (1) to the stop into the bracket (2).
8. Tighten the screw (3) on the bracket (2).
 Tightening torque: 0.2 Nm
9. Adjust sensor (1), see the Sensor Assembly and Operating Manual.

5.3.15 Mounting the radio system RSS-R1/T2

The radio system RSS-R1/T2 can be used with the following sensors:

- Reed switch RMS 80

Assembly

1. Install the sensor, ► [5.3.10](#) [ 34].
2. Adjust the sensor, see the assembly and operating manual for the sensor.
3. Connect the radio system, see the assembly and operating manual for the radio system.

6 Troubleshooting

6.1 Product does not move

Possible cause	Corrective action
Base jaws jam in housing, e.g. mounting surface is not sufficiently even.	Check the evenness of the mounting surface. ▶ 5.2.1 [20]
Pressure drops below minimum.	Check air supply. ▶ 3 [16]
Compressed air lines switched.	Check compressed air lines. ▶ 5.2.2 [23]
Proximity switch defective or set incorrect.	Readjust or change sensor.
Unused air connections open.	Close unused air connections.
Flow control valve closed.	Open the flow control valve.
Component part defective.	Replace component or send it to SCHUNK for repair.

6.2 Product is not executing the complete stroke

Possible cause	Corrective action
Dirt deposits between cover and piston.	Clean and if necessary re-lubricate.
Dirt deposits between basic jaws and guidance.	Disassemble and clean the product.
Pressure drops below minimum.	Check air supply. ▶ 5.2.2 [23]
Mounting surface is not sufficiently flat.	Check the evenness of the mounting surface. ▶ 5.2.1 [20]
Component part defective.	Replace component or send it to SCHUNK for repair.

6.3 Product is opening or closing abruptly

Possible cause	Corrective action
Too little grease in the mechanical guiding areas.	Clean and lubricate product.
Compressed air lines blocked.	Check compressed air lines of damage.
Mounting surface is not sufficiently flat.	Check the evenness of the mounting surface.

6.4 Gripping force is dropping

Possible cause	Corrective action
Compressed air can escape.	Check seals, if necessary, disassemble the product and replace seals.
Too much grease in the mechanical movement space.	Clean and lubricate product.

Possible cause	Corrective action
Pressure drops below minimum.	Check air supply. ▶ 3 [16]
Component part defective.	Replace component or send it to SCHUNK for repair.

6.5 Product does not achieve the opening and closing times

Possible cause	Corrective action
Compressed air lines are not installed optimally.	<p>If present: Open the flow control couplings on the product to the maximum that the movement of the jaws occurs without bouncing and hitting.</p> <p>Check compressed air lines.</p> <p>Inner diameters of compressed air lines are of sufficient size in relation to compressed air consumption.</p> <p>Keep compressed air lines between the product and directional control valve as short as possible.</p> <p>Flow rate of valve is sufficiently large relative to the compressed air consumption.</p> <p>If you still cannot achieve the open and close times in the latest catalog, we recommend the use of quick-air-vent-valves directly at the product.</p>

6.6 Programmable magnetic switches not switching as desired

Possible cause	Corrective action
Incorrect position of sensor	Check adjustment dimensions, ▶ 5.3.4 [27].
Magnetic field too weak	Check function of sensor in both grooves.

7 Maintenance

7.1 Notes

Original spare parts

Use only original spare parts of SCHUNK when replacing spare and wear parts.

Replacement of the housing and base jaws

The base jaws and the guides in the housing are matched to each other. To replace these parts, send the product to SCHUNK with a repair order.

Maintenance of version with gripping force maintenance I.D. gripping and O.D. gripping

The pistons have to be aligned using an assembly device. Therefore we recommend to have the module serviced and the seals replaced by SCHUNK.

7.2 Maintenance intervals

CAUTION

Material damage due to hardening lubricants!

Lubricants harden more quickly at temperatures above 60°C, leading to possible product damage.

- Reduce the lubricant intervals accordingly.

Interval (million cycles)	Maintenance work
2	Clean all parts thoroughly, check for damage and wear, if necessary replace seals and wearing parts, ▶ 7.4 [48]. The seals are in the enclosed sealing kit. ▶ 1.4.1 [7].
2	Clean all parts thoroughly, check for damage and wear, if necessary replace seals and wearing parts, ▶ 7.7 [51] Oil or grease external steel parts.

Tab.: Maintenance- and lubrication interval

7.3 Lubricants/Lubrication points

SCHUNK recommends the lubricants listed.

Greasing area	Lubricant
Metallic sliding surfaces	SCHUNK grease 3
Seals and sealing surfaces	SCHUNK grease 1
Bore hole at the piston	SCHUNK grease 1

Details regarding SCHUNK lubricant designations are available at [schunk.com/lubricants](https://www.schunk.com/lubricants).

The product contains food-compliant lubricants as standard.

The requirements of standard EN 1672-2:2020 are not fully met.

During maintenance, treat all greased areas with lubricant.

Thinly apply lubricant with a lint-free cloth.

NOTE

- Change contaminated food-compliant lubricant.
 - Observe information in the safety data sheet from the lubricant manufacturer.
-

The guides in the housing can be re-lubricated as needed.

Remove the set-screw of the air purge connection and replace it with a lubrication nipple.

7.4 Disassembly and assembly

7.4.1 Dismantling (variant without gripping force maintenance)

Position of the item numbers ▶ 7.7 [51]



⚠ WARNING

Risk of injury when the machine/system moves unexpectedly.

Remove the energy supplies.

1. Remove all compressed air lines, ▶ 5.2.2 [23].
2. Unfasten the set screws and remove the star-shaped pressure piece.
3. Remove the cover (5).
4. Mark the installation positions of the piston (3/8) and the base jaw (2) on the housing (50).
5. Unscrew the screws (41) and remove the cover (4).
6. Mark the installation position between the cylinder piston (6) and the housing (50).
7. Unscrew lock nut (13) and remove cylinder piston (6) from the housing.
8. Push the piston (3/8) upwards out of the housing (50).
9. Pull the base jaws (2) out of the housing (50).

7.4.2 Disassembly (variant with gripping force maintenance "O.D. gripping")

Position of the item numbers ▶ 7.7 [51]



⚠ WARNING

Risk of injury when the machine/system moves unexpectedly.

Remove the energy supplies.

1. Remove the compressed air hoses.
2. Remove the cover (5).
3. Mark the installation position of the piston (3/8) and the base jaws (2) in the housing (50).
4. **WARNING Risk of injury due to spring forces! The cover is under spring tension. Carefully disassemble the module.** Clamp the module between the base jaws (2) and the cover (9) in the vise such that it is still possible to remove the 4 screws (46).
5. Unscrew the screws (46).
6. Carefully open the bench vise and remove the cover (9).

7. Remove the cylindrical pin (57).
8. **WARNING Risk of injury due to spring forces! The cylinder pin is under spring tension. Carefully disassemble the module.** Mark the installation position of the piston (10) and the housing (50).
9. Clamp the module between the base jaws (2) and the cylinder pin (10).
10. Unscrew the screw nut (13).
11. Carefully open the bench vise to remove the surface tension of the pressure spring (26).
12. Remove the cylinder piston (10) out of the housing (50).
13. Remove the distance bolts (25) from the housing (50).
14. Press the piston (3/8) upwards and out of the housing (50).
15. Pull the base jaws (2) out of the housing (50).

7.4.3 Dismantling (variant with gripping force maintenance "I.D. gripping")

Position of the item numbers ► 7.7 [51]



⚠ WARNING

Risk of injury when the machine/system moves unexpectedly.
Remove the energy supplies.

1. Remove the compressed air lines.
2. Remove the cover (5).
3. Mark the installation positions of the piston (3/8) and the base jaws (2) on the housing (50).
4. **WARNING Risk of injury due to spring forces! The cover is under spring tension. Carefully disassemble the module.** Clamp the module between the base jaws (2) and the cover (9) in the vise so that it is still possible to remove the four screws (46).
5. Unscrew the screws (46).
6. Carefully open the vise until the compression spring (26) has no more tension.
7. Remove the cover (9) and the compression spring (26).
8. Mark the installation position between the cylinder piston (10) and the housing (50).
9. Unscrew lock nut (13) and remove cylinder piston (6) from the housing.
10. Push the pistons (3/8) upwards out of the housing (50).

11. Pull the base jaws (2) out of the housing (50).

7.5 Notes for assembly

Assembly takes place in the opposite order to disassembly.
Observe the following:

- Unless otherwise specified, secure all screws and nuts with Loctite no. 243 and tighten with the appropriate tightening torque. ▶ 7.6 [50]

7.6 Screw tightening torques

Position of the item numbers: ▶ 7.7 [51]

Size	Item 13	Item 41	Item 46
50	10	1.2	1.2
64	10	1.2	1.2
80	20	3	3
100	20	3	3
125	40	6	6
160	80	8.5	10
200	100	25	25
240	150	25	25
300	200	49	49

Tab.: Tightening torque [Nm]

7.7 Assembly drawing

The following figure is an example image.

It serves for illustration and assignment of the spare parts.
Variations are possible depending on size and variant.

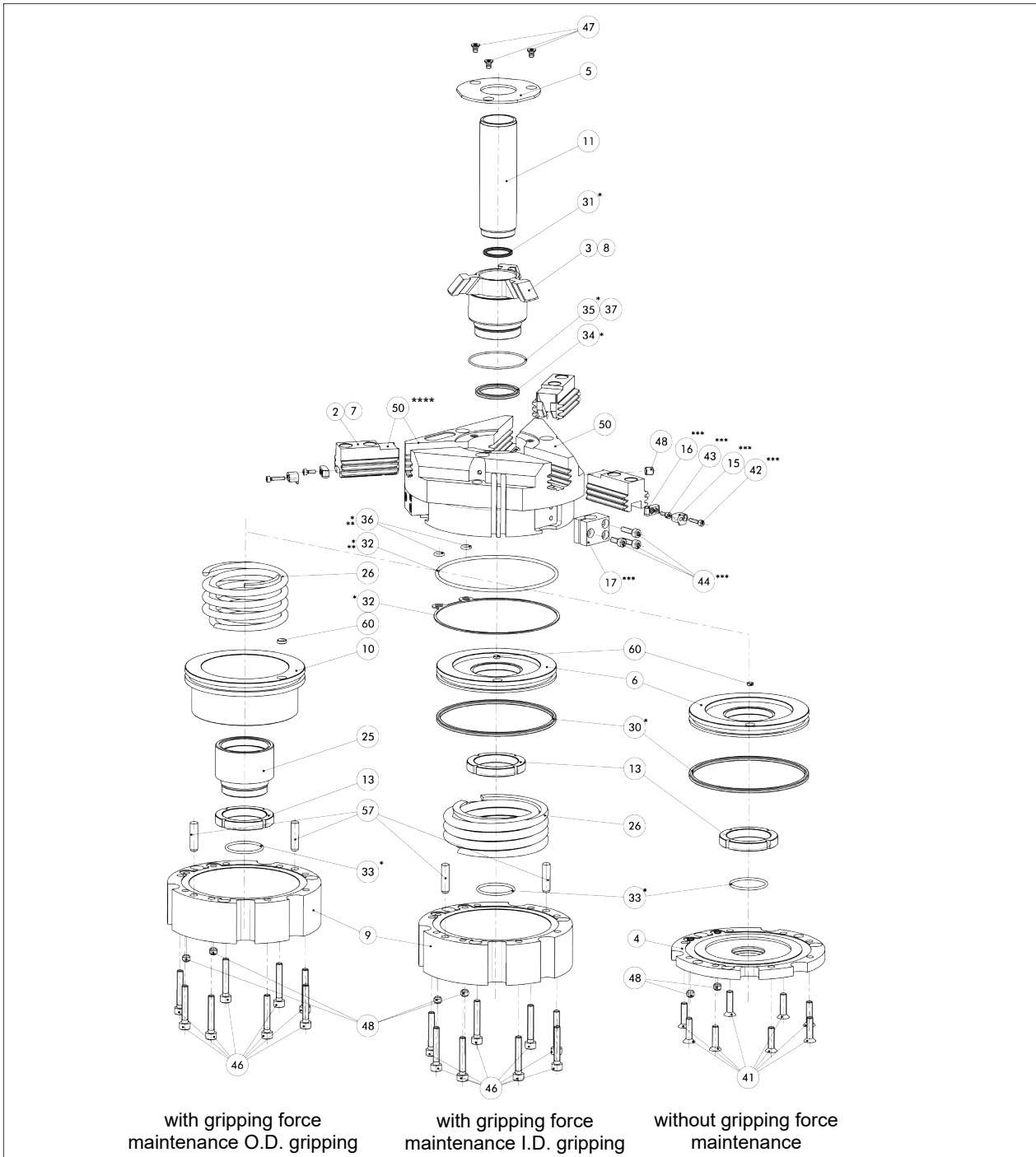

Assembling the variants

* Wearing part, replace during maintenance.
Included in the seal kit. Seal kit can only be ordered completely.

** in sizes 100 – 300

*** in sizes 80 – 300

** in sizes 100 – 300

** nicht relevant bei Baugröße 50 – 80

*** in sizes 80 – 300

*** not relevant for size 50 – 64

**** Positions are adapted to each other and can not be replaced by the customer.

8 Translation of the original declaration of incorporation

in terms of the Directive 2006/42/EG, Annex II, Part 1 Section B.

Manufacturer/ Distributor SCHUNK SE & Co. KG
Spanntechnik | Greiftechnik | Automatisierungstechnik
Bahnhofstr. 106 – 134
D-74348 Lauffen/Neckar

We hereby declare that the partly completed machine described below

Product designation: 3-Finger-Centric Gripper / PZB-plus /pneumatic
ID number 0304950 ... 0304975, 0305140...0305194

meets the following basic occupational health and safety of the Machinery Directive 2006/42/EC:

No. 1.1.1, No. 1.1.2, No. 1.1.3, No. 1.1.5, No. 1.3.2, No. 1.5.3, No. 1.5.4, No. 1.5.6, No. 1.5.8, No. 1.5.10, No. 1.5.11, No. 1.5.13

The partly completed machinery may not be put into operation until it has been confirmed that the machine into which the partly completed machinery is to be installed complies with the provisions of the Machinery Directive (2006/42/EC). The declaration shall be rendered invalid if modifications are made to the product.

Applied harmonized standards, especially:

EN ISO 12100:2010 Safety of machinery – General principles for design –
Risk assessment and risk reduction

The special technical documentation according to Annex VII, Part B, belonging to the partly completed machine, has been created.

Person authorized to compile the technical documentation:
Stefanie Walter, Address: see manufacturer's address

Signature: see original declaration

Lauffen/Neckar, July 2024

Dr.-Ing. Manuel Baumeister,
Head of Systems Engineering,
Technology & Innovation

9 UKCA declaration of incorporation

in accordance with the Supply of Machinery (Safety) Regulations 2008.

Manufacturer/
Distributor SCHUNK Intec Limited
 Clamping and gripping technology
 3 Drakes Mews, Crownhill
 MK8 0ER Milton Keynes

We hereby declare that on the date of the declaration the following partly completed machine complied with all basic safety and health regulations found in the "Supply of Machinery (Safety) Regulations 2008".

The declaration shall be rendered invalid if modifications are made to the product.

Product designation: 3-Finger-Centric Gripper / PZB-plus / pneumatic
ID number 0304950 ... 0304975, 0305140...0305194

The partly completed machine may not be put into operation until it has been confirmed that the machine into which the partly completed machine is to be installed complies with the provisions of the "Supply of Machinery (Safety) Regulations 2008".

Applied harmonized standards, especially:

EN ISO 12100:2010 Safety of machinery – General principles for design –
 Risk assessment and risk reduction

The special technical documentation according to Annex VII, Part B, belonging to the partly completed machine, has been created.

Person authorized to compile the technical documentation:
Marcel Machado, address: refer to manufacturer's address

Lauffen/Neckar, July 2024



Dr.-Ing. Manuel Baumeister,
Head of Systems Engineering,
Technology & Innovation

10 Information on the RoHS Directive, REACH Regulation and Substances of Very High Concern (SVHC)

RoHS Directive

SCHUNK products are classified as "large-scale stationary installations" or as "large-scale stationary industrial tools" within the meaning of Directive 2011/65/EU and its extension 2015/863/EU "on the restriction of the use of certain hazardous substances in electrical and electronic equipment (RoHS)", or fulfill their intended function only as part of one. Therefore products from SCHUNK do not fall within the scope of the directive at this time.

REACH Regulation

Products from SCHUNK fully comply with the regulations of Regulation (EC) No. 1907/2006 "concerning the Registration, Evaluation, Authorization and Restriction of Chemicals (REACH)" and its amendment 2022/477. SCHUNK attaches great importance to completely avoiding chemicals of concern to humans and the environment wherever possible.

Only in rare exceptional cases do SCHUNK products contain SVHC substances on the candidate list with a mass content above 0.1%. In accordance with Article. 33 (1) of Regulation (EC) No. 1907/2006, SCHUNK complies with its duty to "communicate information on substances in articles" and lists the components concerned and the substances used in an overview that can be viewed at [schunk.com\SVHC](https://www.schunk.com/SVHC).

Signature: see original declaration

Lauffen/Neckar, July 2024

Dr.-Ing. Manuel Baumeister,
Head of Systems Engineering,
Technology & Innovation

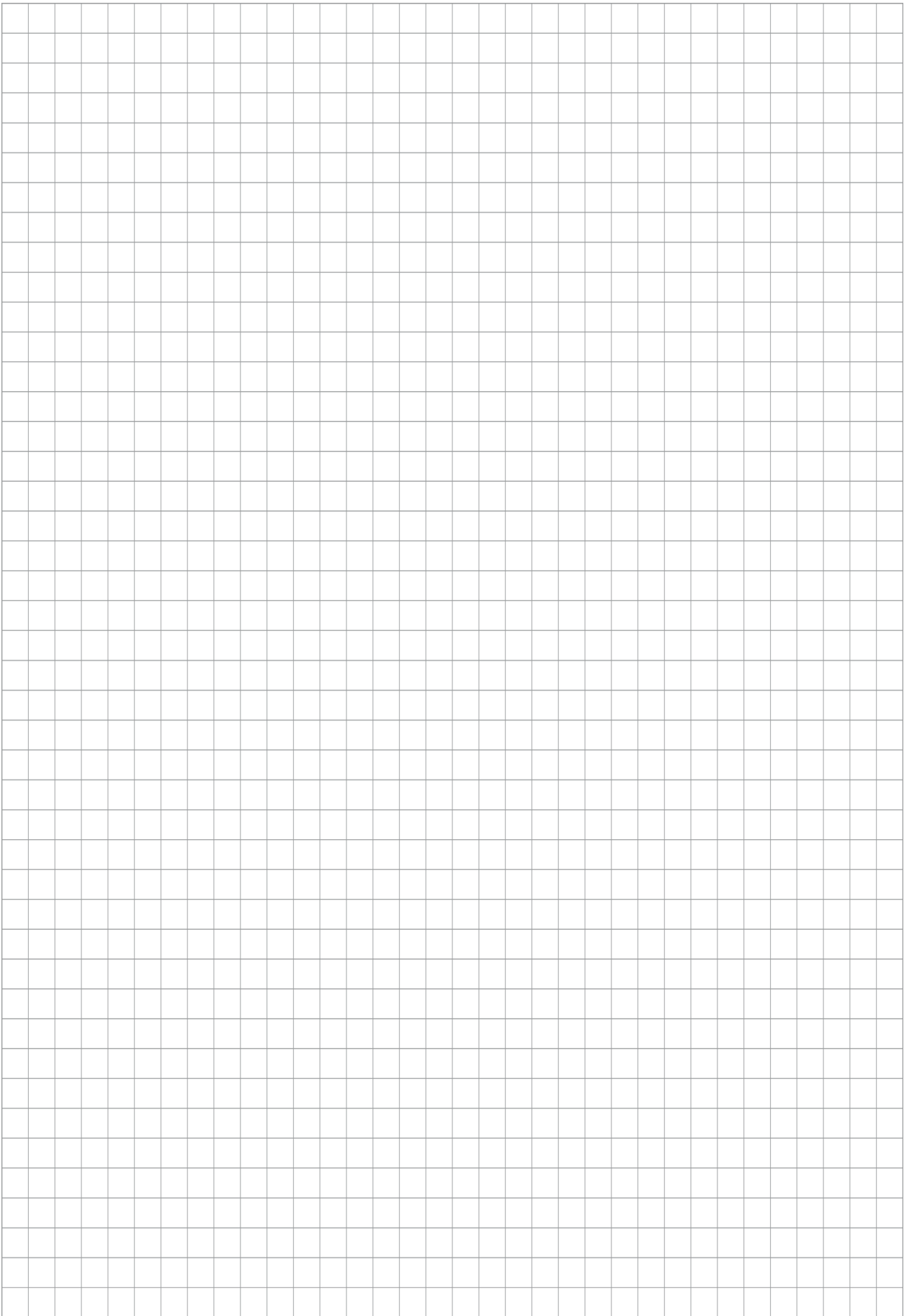



SCHUNK SE & Co. KG
Spanntechnik | Greiftechnik | Automatisierungstechnik

Bahnhofstr. 106 - 134
D-74348 Lauffen/Neckar
Tel. +49-7133-103-0
info@de.schunk.com
schunk.com

Folgen Sie uns | *Follow us*



Wir drucken nachhaltig | *We print sustainable*