



Assembly and Operating Manual

HLM

Stroke Module

Translation of Original Operating
Manual

Imprint

Copyright:

This manual is protected by copyright. The author is SCHUNK SE & Co. KG.
All rights reserved.

Technical changes:

We reserve the right to make alterations for the purpose of technical improvement.

Document number: 389497

Version: 04.00 | 17/04/2024 | en

Dear Customer,

Thank you for trusting our products and our family-owned company, the leading technology supplier of robots and production machines.

Our team is always available to answer any questions on this product and other solutions. Ask us questions and challenge us. We will find a solution!

Best regards,

Your SCHUNK team

Customer Management

Tel. +49-7133-103-2503

Fax +49-7133-103-2189

cmg@de.schunk.com



Please read the operating manual in full and keep it close to the product.

Table of Contents

1 General	5
1.1 About this manual.....	5
1.1.1 Presentation of Warning Labels	5
1.1.2 Definition of Terms	6
1.1.3 Applicable documents	6
1.1.4 Sizes.....	6
1.2 Warranty	7
1.3 Scope of delivery.....	7
1.4 Accessories	8
1.4.1 Sensors	8
1.4.2 Rod lock.....	8
2 Basic safety notes	9
2.1 Intended use.....	9
2.2 Not intended use	9
2.3 Constructional changes.....	9
2.4 Spare parts	9
2.5 Environmental and operating conditions.....	10
2.6 Personnel qualification	10
2.7 Personal protective equipment	11
2.8 Notes on safe operation.....	11
2.9 Transport.....	11
2.10 Malfunctions.....	12
2.11 Disposal	12
2.12 Fundamental dangers	12
2.12.1 Protection during handling and assembly	13
2.12.2 Protection during commissioning and operation	13
2.12.3 Protection against dangerous movements	13
2.12.4 Protection against electric shock.....	14
2.13 Information about special dangers.....	14
3 Technical Data	16
4 Assembly and Installation.....	17
4.1 Mechanical connection.....	17
4.2 Air connection	19
4.3 Setting the speed	20
4.4 Adjustment of the shock absorber stroke.....	21
4.5 End positions	22
4.5.1 Rod lock.....	23
4.5.2 Stroke adjustment.....	25

4.6 Damping adjustment	25
5 Commissioning	27
6 Troubleshooting.....	28
6.1 Module does not move	28
6.2 End position signal not present.....	28
6.3 Linear module proposes at the end positions	28
6.4 Nutzlast schwingt in der Endlage	28
7 Maintenance and care	29
8 Spare parts	30
8.1 HLM 25.....	30
8.2 HLM 50, 100 and 200	31
9 Translation of the original declaration of incorporation	32
10 UKCA declaration of incorporation	33
11 Information on the RoHS Directive, REACH Regulation and Substances of Very High Concern (SVHC)	34

1 General

1.1 About this manual

This manual contains important information for a safe and appropriate use of the product.

This manual is an integral part of the product and must be kept accessible for the personnel at all times.

Before starting work, the personnel must have read and understood this operating manual. Prerequisite for safe working is the observance of all safety instructions in this manual.

In addition to these instructions, the documents listed under ► 1.1.3 [6] are applicable.

NOTE: The illustrations in this manual are intended to provide a basic understanding and may deviate from the actual version.

1.1.1 Presentation of Warning Labels

To make risks clear, the following signal words and symbols are used for safety notes.



⚠ DANGER

Dangers for persons!

Non-observance will inevitably cause irreversible injury or death.



⚠ WARNING

Dangers for persons!

Non-observance can lead to irreversible injury and even death.



⚠ CAUTION

Dangers for persons!

Non-observance can cause minor injuries.

CAUTION

Material damage!

Information about avoiding material damage.

1.1.2 Definition of Terms

The term "product" replaces the product name on the title page in this manual.

1.1.3 Applicable documents

- General terms of business *
- Catalog data sheet of the purchased product *
- Assembly and operating manuals of the accessories *

The documents labeled with an asterisk (*) can be downloaded from schunk.com/downloads.

1.1.4 Sizes

This operating manual applies to the following sizes:

- HLM 25
- HLM 50
- HLM 100
- HLM 200

1.2 Warranty

If the product is used as intended, the warranty is valid for 24 months from the ex-works delivery date under the following conditions:

- Observe the ambient conditions and operating conditions, ▶ 2.5 [📄 10]
- Observe the specified maintenance intervals, ▶ 7 [📄 29]

Parts touching the workpiece and wear parts are not included in the warranty.

1.3 Scope of delivery

The scope of delivery includes

- Stroke Module HLM in the version ordered
- Shock absorber
- Assembly and Operating Manual

1.4 Accessories

A wide range of accessories are available for this product
 For information regarding which accessory articles can be used with the corresponding product variants, see catalog data sheet.

1.4.1 Sensors

Size	Designation	Type
HLM 25 – 50	Inductive proximity switches	IN
HLM 100–200	Inductive proximity switches	NI

Exact type designation of the compatible sensors see catalog.

1.4.2 Rod lock

The rod lock prevents the drop of the mass in case of energy loss, such as emergency stop situations. The rod can be fitted subsequently, but this reduces the effective stroke.

CAUTION

Damage to the rod lock due to incorrect actuation / overload!

- The rod lock may only be triggered and unlocked when the product has been shut down.
- See the data on static holding force in the catalog. The forces occurring in a clamped condition must not exceed the holding force.
- In the event of a dynamic load or overload (e.g. drop in pressure during movement), the clamping cartridge must be checked and replaced if necessary.



⚠ WARNING

The Rod lock is not a safety component for personal protection in accordance with the Machinery Directive.

Exact specifications and ordering data  catalog.

2 Basic safety notes

2.1 Intended use

The product is exclusively designed for linear movement of useful loads into any desired position.

- The product may only be used within the scope of its technical data, ▶ 3 [16].
- When implementing and operating components in safety-related parts of the control systems, the basic safety principles in accordance with DIN EN ISO 13849-2 apply. The proven safety principles in accordance with DIN EN ISO 13849-2 also apply to categories 1, 2, 3 and 4.
- The product is intended for installation in a machine/ automated system. The applicable guidelines for the machine/ automated system must be observed and complied with.
- The product is intended for industrial and industry-oriented use.
- Appropriate use of the product includes compliance with all instructions in this manual.

2.2 Not intended use

It is not intended use if the product is used, for example, as a pressing tool, stamping tool, lifting gear, guide for tools, cutting tool, clamping device or a drilling tool.

- Any utilization that exceeds or differs from the appropriate use is regarded as misuse.

2.3 Constructional changes

Implementation of structural changes

Modifications, changes or reworking, e.g. additional threads, holes, or safety devices, can damage the product or impair its functionality or safety.

- Structural changes should only be made with the written approval of SCHUNK.

2.4 Spare parts

Use of unauthorized spare parts

Using unauthorized spare parts can endanger personnel and damage the product or cause it to malfunction.

- Use only original spare parts or spares authorized by SCHUNK.

2.5 Environmental and operating conditions

- Make sure that the product is used only in the context of its defined application parameters, ▶ 3 [16].
- Make sure that the product is not exposed to excessive vibrations and/or strokes.
- Make sure that the environment is free from splash water and vapors as well as from abrasion or processing dust. Exceptions are products that are designed especially for contaminated environments.
- Make sure that the environment is clean and the ambient temperature corresponds to the specifications per the catalog.
- Ensure that no strong magnetic fields impair the function of the product.
Contact your SCHUNK partner if the product is to be used in strong magnetic fields.

2.6 Personnel qualification

Inadequate qualifications of the personnel

If the personnel working with the product is not sufficiently qualified, the result may be serious injuries and significant property damage.

- All work may only be performed by qualified personnel.
- Before working with the product, the personnel must have read and understood the complete assembly and operating manual.
- Observe the national safety regulations and rules and general safety instructions.

The following personal qualifications are necessary for the various activities related to the product:

Trained electrician

Due to their technical training, knowledge and experience, trained electricians are able to work on electrical systems, recognize and avoid possible dangers and know the relevant standards and regulations.

Qualified personnel

Due to its technical training, knowledge and experience, qualified personnel is able to perform the delegated tasks, recognize and avoid possible dangers and knows the relevant standards and regulations.

Instructed person

Instructed persons were instructed by the operator about the delegated tasks and possible dangers due to improper behaviour.

Service personnel of the manufacturer Due to its technical training, knowledge and experience, service personnel of the manufacturer is able to perform the delegated tasks and to recognize and avoid possible dangers.

2.7 Personal protective equipment

Use of personal protective equipment

Personal protective equipment serves to protect staff against danger which may interfere with their health or safety at work.

- When working on and with the product, observe the occupational health and safety regulations and wear the required personal protective equipment.
- Observe the valid safety and accident prevention regulations.
- Wear protective gloves to guard against sharp edges and corners or rough surfaces.
- Wear heat-resistant protective gloves when handling hot surfaces.
- Wear protective gloves and safety goggles when handling hazardous substances.
- Wear close-fitting protective clothing and also wear long hair in a hairnet when dealing with moving components.

2.8 Notes on safe operation

Incorrect handling of the personnel

Incorrect handling and assembly may impair the product's safety and cause serious injuries and considerable material damage.

- Avoid any manner of working that may interfere with the function and operational safety of the product.
- Use the product as intended.
- Observe the safety notes and assembly instructions.
- Do not expose the product to any corrosive media. This does not apply to products that are designed for special environments.
- Eliminate any malfunction immediately.
- Observe the care and maintenance instructions.
- Observe the current safety, accident prevention and environmental protection regulations regarding the product's application field.

2.9 Transport

Handling during transport

Incorrect handling during transport may impair the product's safety and cause serious injuries and considerable material damage.

- When handling heavy weights, use lifting equipment to lift the product and transport it by appropriate means.
- Secure the product against falling during transportation and handling.
- Stand clear of suspended loads.

2.10 Malfunctions

Behavior in case of malfunctions

- Immediately remove the product from operation and report the malfunction to the responsible departments/persons.
- Order appropriately trained personnel to rectify the malfunction.
- Do not recommission the product until the malfunction has been rectified.
- Test the product after a malfunction to establish whether it still functions properly and no increased risks have arisen.

2.11 Disposal

Handling of disposal

The incorrect handling of disposal may impair the product's safety and cause serious injuries as well as considerable material and environmental harm.

- Follow local regulations on dispatching product components for recycling or proper disposal.

2.12 Fundamental dangers

General

- Observe safety distances.
- Never deactivate safety devices.
- Before commissioning the product, take appropriate protective measures to secure the danger zone.
- Disconnect power sources before installation, modification, maintenance, or calibration. Ensure that no residual energy remains in the system.
- If the energy supply is connected, do not move any parts by hand.
- Do not reach into the open mechanism or movement area of the product during operation.

2.12.1 Protection during handling and assembly

Incorrect handling and assembly

Incorrect handling and assembly may impair the product's safety and cause serious injuries and considerable material damage.

- Have all work carried out by appropriately qualified personnel.
- For all work, secure the product against accidental operation.
- Observe the relevant accident prevention rules.
- Use suitable assembly and transport equipment and take precautions to prevent jamming and crushing.

Incorrect lifting of loads

Falling loads may cause serious injuries and even death.

- Stand clear of suspended loads and do not step into their swiveling range.
- Never move loads without supervision.
- Do not leave suspended loads unattended.

2.12.2 Protection during commissioning and operation

Falling or violently ejected components

Falling and violently ejected components can cause serious injuries and even death.

- Take appropriate protective measures to secure the danger zone.
- Never step into the danger zone during operation.

2.12.3 Protection against dangerous movements

Unexpected movements

Residual energy in the system may cause serious injuries while working with the product.

- Switch off the energy supply, ensure that no residual energy remains and secure against inadvertent reactivation.
- Never rely solely on the response of the monitoring function to avert danger. Until the installed monitors become effective, it must be assumed that the drive movement is faulty, with its action being dependent on the control unit and the current operating condition of the drive. Perform maintenance work, modifications, and attachments outside the danger zone defined by the movement range.
- To avoid accidents and/or material damage, human access to the movement range of the machine must be restricted. Limit/prevent accidental access for people in this area due through technical safety measures. The protective cover and protective

fence must be rigid enough to withstand the maximum possible movement energy. EMERGENCY STOP switches must be easily and quickly accessible. Before starting up the machine or automated system, check that the EMERGENCY STOP system is working. Prevent operation of the machine if this protective equipment does not function correctly.

2.12.4 Protection against electric shock

Possible electrostatic energy

Components or assembly groups may become electrostatically charged. When the electrostatic charge is touched, the discharge may trigger a shock reaction leading to injuries.

- The operator must ensure that all components and assembly groups are included in the local potential equalisation in accordance with the applicable regulations.
- While paying attention to the actual conditions of the working environment, the potential equalisation must be implemented by a specialist electrician according to the applicable regulations.
- The effectiveness of the potential equalisation must be verified by executing regular safety measurements.

2.13 Information about special dangers



⚠ WARNING

Risk of injury caused by crushing and impacts when moving the unit or attachments!

Risk of injury due to attachments breaking or becoming loose!



⚠ WARNING

Risk of injury from objects falling and being ejected!

Falling and ejected objects during operation can lead to serious injury or death.

- Take appropriate protective measures to secure the danger zone.

**⚠ WARNING****Risk of injury due to unexpected movements!**

If the power supply is switched on or residual energy remains in the system, components can move unexpectedly and cause serious injuries.

- Before starting any work on the product: Switch off the power supply and secure against restarting.
- Make sure, that no residual energy remains in the system.

**⚠ WARNING****Risk of injury when the machine/system moves unexpectedly in the case of a loss of power supply or control system malfunction.**

Use of a holding brake on the linear axis.

3 Technical Data

Size	08 - 200
Ambient temperature [°C]	5 - 60
IP rating	40
Noise emission [dB(A)]	≤ 70
Pressure medium	Compressed air, compressed air quality according to ISO 8573-1:2010 [7:4:4]
Min. pressure [bar]	3
Max. pressure [bar]	8
Nominal working pressure [bar]	6

More technical data is included in the catalog data sheet. Whichever is the latest version.

4 Assembly and Installation

CAUTION

Assembly measures

When mounting the module and when mounting loads, do not allow impermissible forces and moments to be exerted (see catalog data)

Select the suitable screw tightening torque when mounting the module or loads on the module in accordance with the generally accepted guidelines for screw connections.

Secure all screw connections using a suitable chemical screw lock.



WARNING

Risk of injury due to unexpected movements of the machine/system!

Switch off energy supply

Ensure that no residual energy remains in the system.

4.1 Mechanical connection

Evenness of the mounting surface

The values apply to the whole mounting surface to which the product is mounted.

Edge length	Permissible unevenness
< 100	< 0.02
> 100	< 0.05

Tab.: Requirements for evenness of the mounting surface (Dimensions in mm)

The module is assembled on the base plate. Additional connection geometries can be found on the front, rear and on the top of the module:

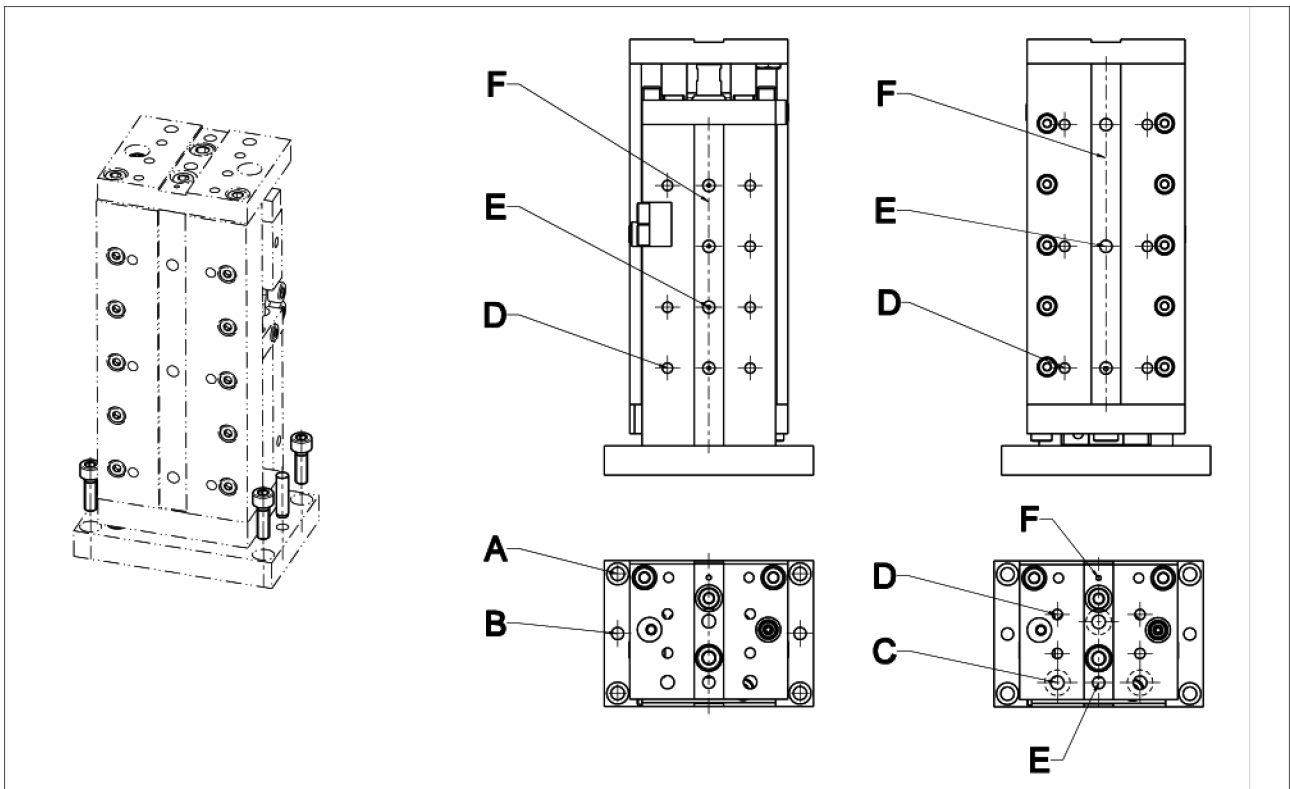

Assembly / connection geometries

Item	Designation	Application	Standard
A	Screw	Mounting Module	DEI 4762
B	Cylindrical pin	Centering, module	ISO 8734
C *	Bore hole	Mounting Load	
D *	Thread	Mounting Load	
E *	Cylindrical pin	Centering, load	ISO 8734
F *	Centering strip	Centering, load	

For in-depth details regarding dimensions and position, refer to the current catalog or CAD data.

The customer must provide the fastening materials.

4.2 Air connection

CAUTION

Possible damage to the linear module!

If the unit moves too hard into the end position, the linear module may be damaged.

- A linear movement must always be free of impact and bounce.
- For this purpose, carry out sufficient throttling and damping, ▶ 4.4 [21].
- Observe the specifications in the catalog data sheet.

NOTE

- Use connecting wires with the same or a larger cross-section as the connection thread.
- Observe the air supply requirements ▶ 3 [16].

CAUTION

Risk of damage to the linear module when changing pressure medium.

The unit must not under any circumstances be operated with oiled air before operation with unoled air (washing out of factory lubrication).

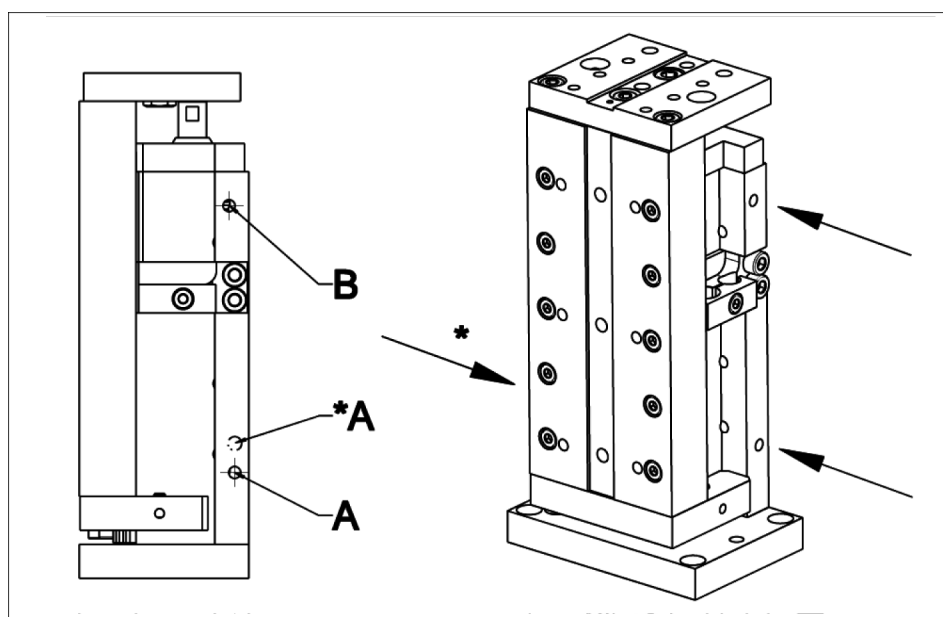

air connection * HLM 025

Item	25	50	100	200
A ^(*)	M5	M5	M5	G1/8"
B	M5	M5	M5	G1/8"

4.3 Setting the speed

CAUTION

Material damage due to erroneous settings!

If the end position is approached too hard, the product may be damaged.

- Adjust exhaust throttle valve and shock absorber so that the movement is braked smoothly.

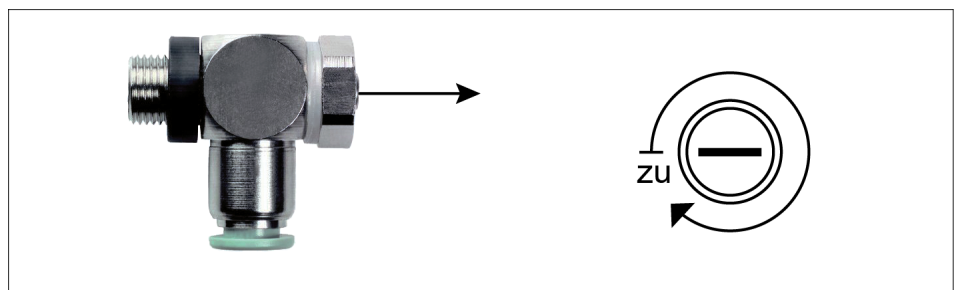

1. Close exhaust throttle valve completely.

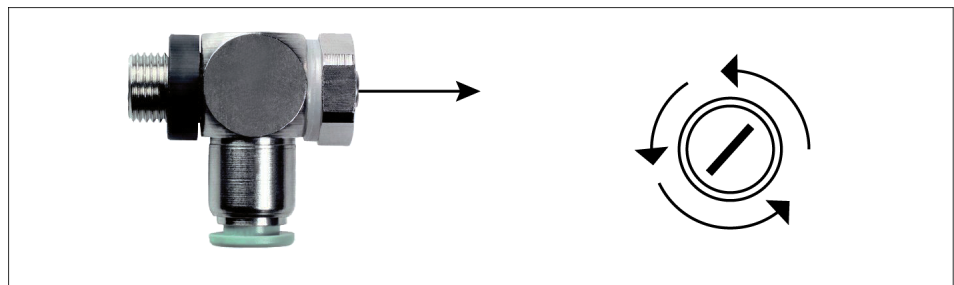

2. Open exhaust throttle valve until the product starts to move.
3. Continue to open the exhaust throttle valve incrementally until the movement decelerates smoothly.
 - ⇒ If the speed is too low, the product will brake too soon and the end position will be reached too slowly.
 - ⇒ If the speed is too high, the product will impact against the end position and the shock absorber will be overloaded.

NOTE

A smooth motion may also be too slow in many use-cases. Further settings can be made via the shock absorbers, ▶ 4.4 [21].

4.4 Adjustment of the shock absorber stroke

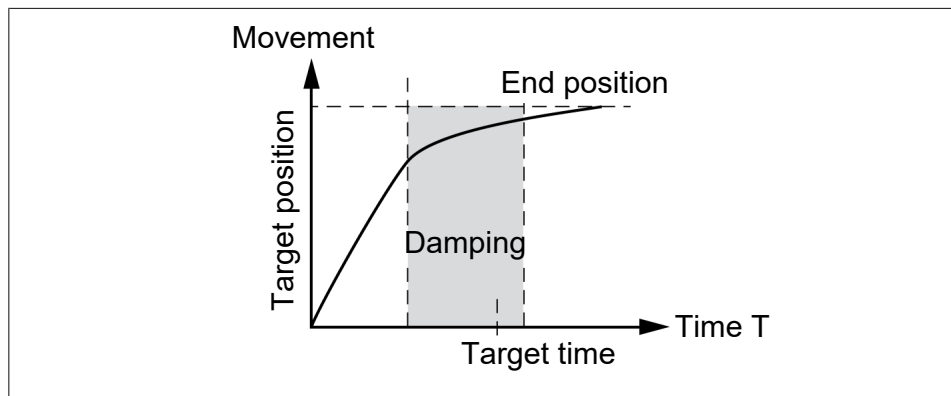

The shock absorber stroke is too long and the end position is reached too slowly.

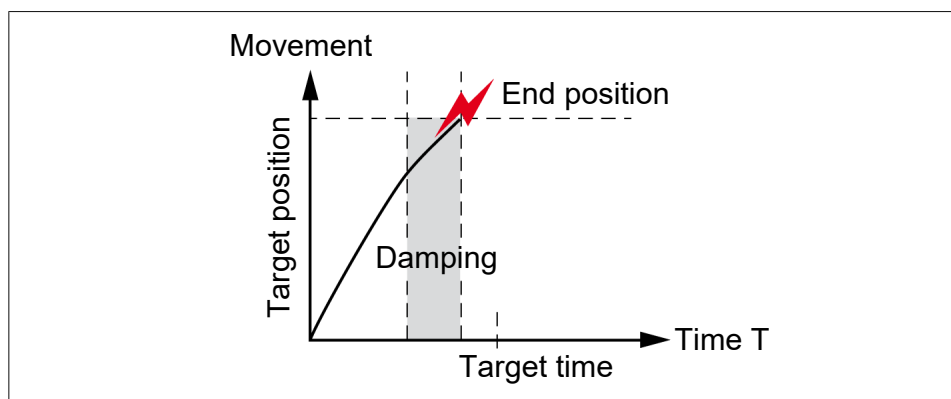

The shock absorber stroke is too short and the unit arrives in the end position too abruptly.

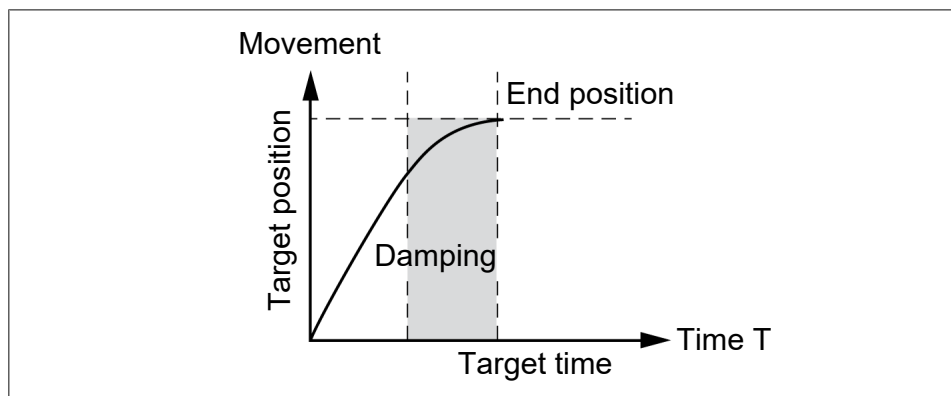

Optimal shock absorber stroke.

4.5 End positions

The following components are available for stroke limiting, shock absorption and monitoring of the end positions:

- Shock absorber – stop LMST (included in the scope of delivery)
- Damping adjustment LMD (included in the scope of delivery)
- Sensors (optional) ▶ 1.4.1 [8]

The installation of LMST-... and NI-... is shown in the following:

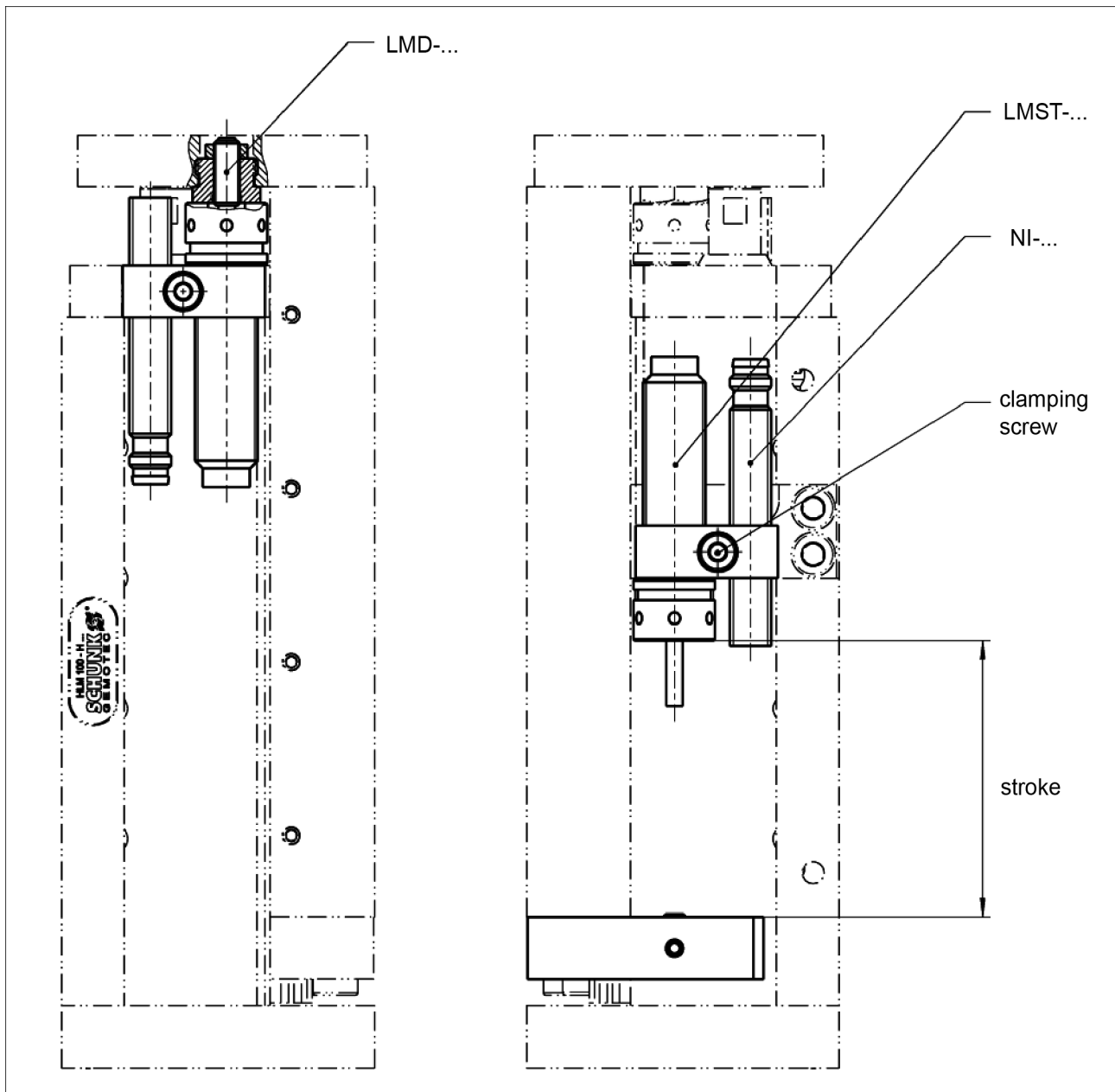

Linear module end positions

4.5.1 Rod lock

CAUTION

Damage to the rod lock due to incorrect actuation / overload!

- The rod lock may only be triggered and unlocked when the product has been shut down.
- See the data on static holding force in the catalog. The forces occurring in a clamped condition must not exceed the holding force.
- In the event of a dynamic load or overload (e.g. drop in pressure during movement), the clamping cartridge must be checked and replaced if necessary.



⚠ WARNING

The rod lock is not a safety component for personal protection in the sense of the Machine Directive.

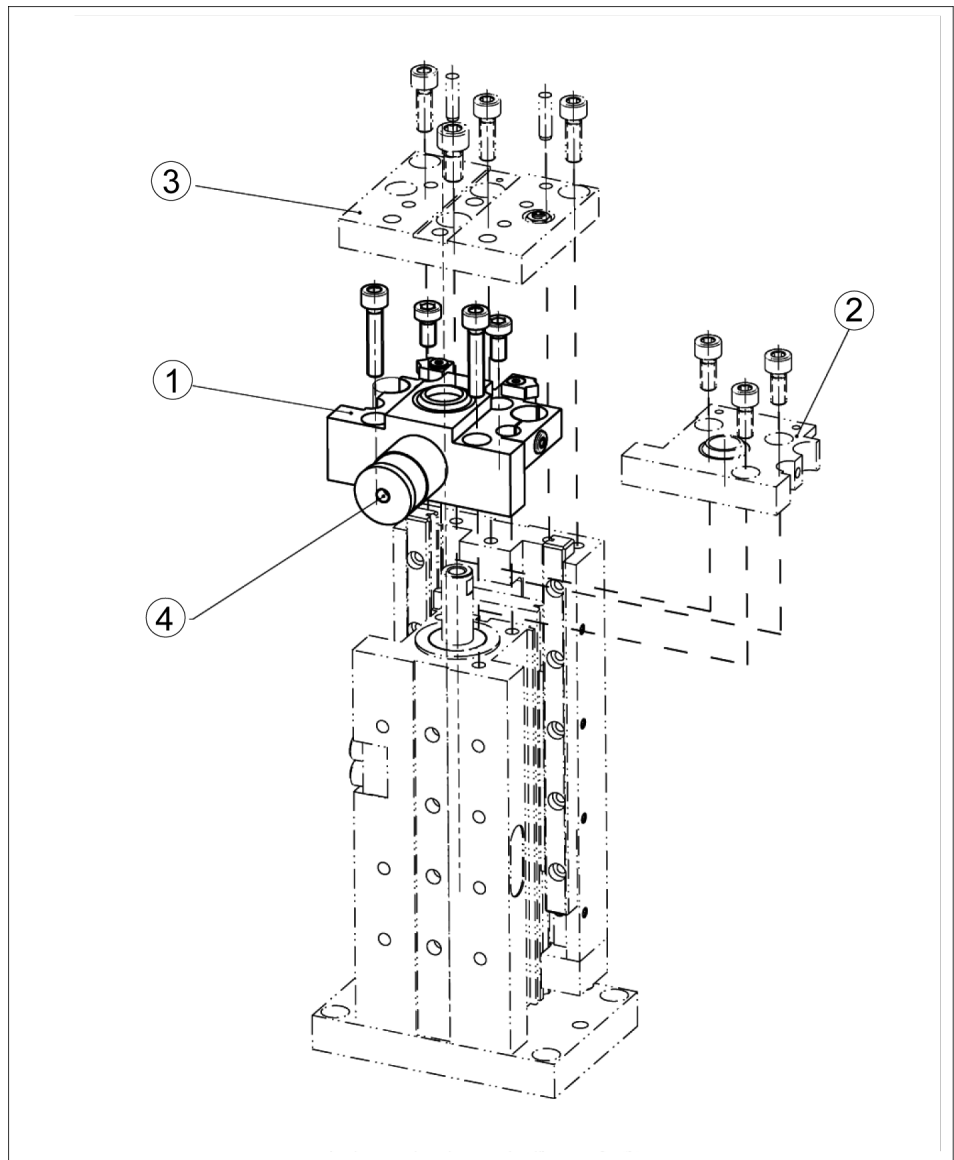

Rod lock

Item	Designation	Thread
4	Air connection	M5

Assembly of ASP rod lock

1. Remove face plate I (3) and cover plate I (2)
2. Install the completely installed rod lock (A) on the module.
Grease wiper ring! ▶ 7 [29]
 The cover plate (2) is no longer required.
3. Install face plate I (3) on the module.
4. Remove screw from air connection (4) clamping is now active and must be released with the corresponding air pressure.

4.5.2 Stroke adjustment

In order to adjust the linear module stroke, the LMST-... shock absorber stop and the NI-... proximity switch can be adjusted after undoing the attachment screw.

Retighten the clamping after setting the desired stroke.

Linear module	Max. permissible screw tightening torque at strength class 8.8:
HLM 025*	1.5Nm
HLM 050*	1.5Nm
HLM 100	3.0Nm
HLM 200	5.9Nm

The maximum possible end position adjustment is listed in the SCHUNK catalog "Modular assembly automation".

4.6 Damping adjustment

To adapt the damping characteristic of the apparent kinetic energy, the damper stroke and thus the characteristics can be adjusted.

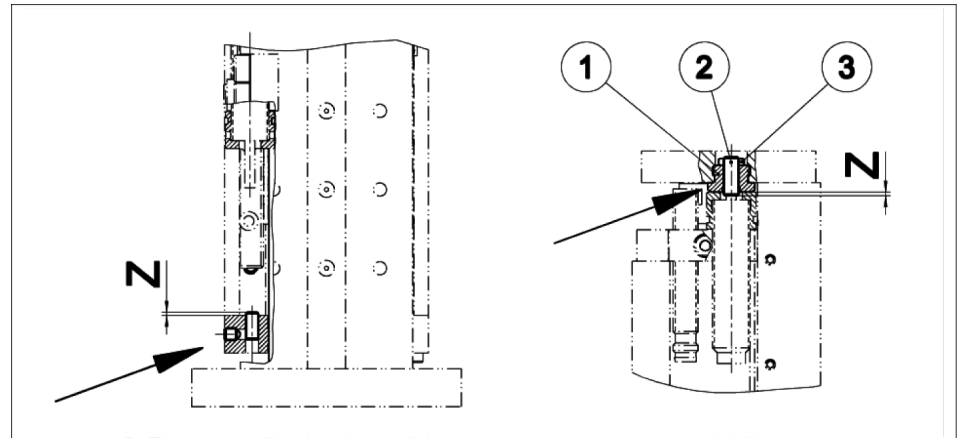

Damper adjustment

**Damping adjustment
end position retracted
(right view)**

1. Remove the stop screw (1) from the plate and undo the counter nut (3).
2. Set the setscrew (2) to the desired dimension. ! Caution, observe the setting range. (See below)
3. Tighten the setscrew (2) and reinstall the stop screw (1) in the plate.

**Damping adjustment
end position
extended (left view)**

1. Undo the attachment screw.
2. Set the damping adjustment setscrew to the desired dimension. **Caution, observe the setting range.**
3. Secure the setscrew again with the attachment screw.

Linear module	Damping adjustment dimension Z
HLM 025	-1.3...0 mm
HLM 050	0...+1.8 mm
HLM 100	-0.6...+2.4 mm
HLM 200	-1.8...+1.8 mm

5 Commissioning

CAUTION

Prior to commissioning!

Please read this operating manual carefully. Faults can be avoided and problem-free operation can be ensured only with the knowledge contained in this operating manual.

- Check the technical specifications ▶ 3 [16]
- Do not use the device until perfect operation has been checked taking all permissible operating parameters into account.
- The movement speed must be regulated via throttle check valves ▶ 4.1 [17]. The speed is always set so that it starts at a low speed, and increases to a higher speed until the desired operating speed is reached.

CAUTION

Risk of mechanical damage of the product!

The product must always be adjusted so that no mechanical impacts are produced when reaching the end position.

6 Troubleshooting

6.1 Module does not move

Possible cause	Corrective action
Pressure drops below minimum.	Check air supply. Link Luftanschlüsse
Compressed air lines switched.	Check compressed air lines. Link Luftanschlüsse

6.2 End position signal not present

Possible cause	Corrective action
Proximity switch defective or set incorrect.	Adjust sensor or if necessary change sensor., Link Endlagen
Cable breakage.	Change sensor.

6.3 Linear module proposes at the end positions

Possible cause	Corrective action
Damping wrong adjustet.	Adjust stop screw.
Shock absorber defective.	Change the shock absorber.
Stroke speed too high.	Check / reduce stroke speed with ventilation valves. Change defective exhaust ait throttle if necessary.

6.4 Nutzlast schwingt in der Endlage

Possible cause	Corrective action
Stroke speed too high.	Check / reduce stroke speed with ventilation valves. Change defective exhaust ait throttle if necessary.
Bad damping.	Adjust damping (stop screw). Assembly and Settings
Unfavorable installation.	Check construction.
CLM size too small	Use larger CLM size.

7 Maintenance and care

Activity	Maintenance intervals
Functional test damper	regularly
Change of shock absorber	2 Mio. cycles
Check Condition of the seals	regularly
Change the seals	If necessary
Lubricate the guides	every 3.000 km

The seals are included in the seal kit ► 8 [30]

During maintenance, treat all greased areas with lubricant. Thinly apply lubricant with a lint-free cloth.

SCHUNK recommends the lubricants listed.

During maintenance, treat all greased areas with lubricant. Thinly apply lubricant with a lint-free cloth.

SCHUNK recommends the listed lubricant.

Lubricant point	Lubricant
Seals and sealing surfaces	SCHUNK grease 1
Linear guides	SCHUNK grease 10

Details regarding SCHUNK lubricant designations are available at [schunk.com/lubricants](https://www.schunk.com/lubricants).

The product contains food-compliant lubricants as standard.

The requirements of standard EN 1672-2:2020 are not fully met.

NOTE

- Change contaminated food-compliant lubricant.
- Observe information in the safety data sheet from the lubricant manufacturer.

8 Spare parts

8.1 HLM 25

Seal kits are available as a standardized wearing parts set. All seals are included.

Order Number

- CLMDI 025 (for stroke module HLM 025) ID number 0314214

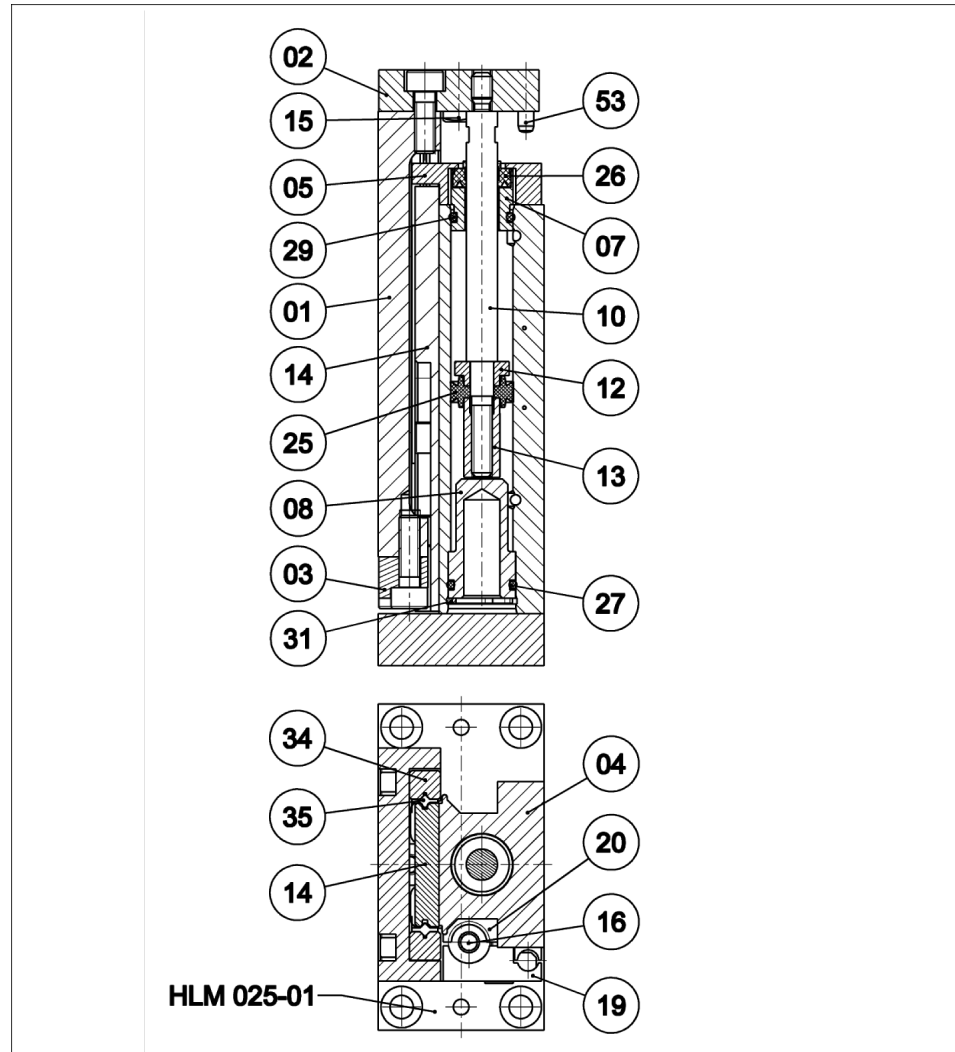

sectional drawing HLM 25

According to the sectional drawing all other wear parts and components are available separately.

Wear parts

Item 14, 25, 26, 27, 29, 34, 35

Order numbers in the following example

Part-No. 1 CLM 25 - H025 - 01

8.2 HLM 50, 100 and 200

Seal kits are available as a standardized wearing parts set. All seals are included.

Order Number

- CLMDI 050 (for stroke module HLM 050) ID number0314216
- CLMDI 100 (for stroke module HLM 100) ID number0314218
- CLMDI 200 (for stroke module HLM 20) ID number0314220

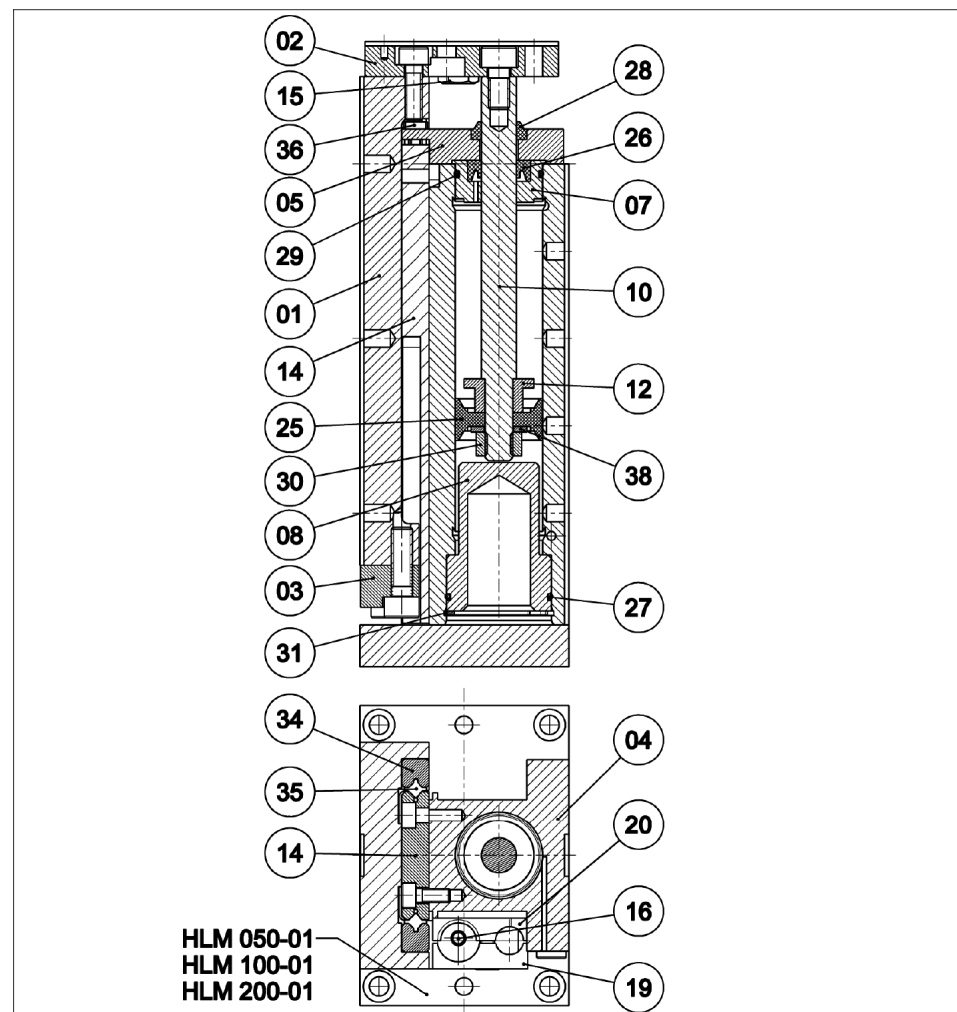

Sectional drawing of HLM 50, 100, 200

According to the sectional drawing all other wear parts and components are available separately.

Wear parts

Item 14, 26, 27, 28, 29, 34, 35, 38

Order numbers in the following example

Part-No. 1 CLM 100 - H075 - 01

9 Translation of the original declaration of incorporation

in terms of the Directive 2006/42/EG, Annex II, Part 1 Section B.

Manufacturer/
Distributor SCHUNK SE & Co. KG
Spanntechnik | Greiftechnik | Automatisierungstechnik
Bahnhofstr. 106 – 134
D-74348 Lauffen/Neckar

We hereby declare that the partly completed machine described below

Product designation: Stroke Module / HLM /pneumatic
ID number 0314574, 0314575, 0314576, 0314577, 0314578, 0314579, 0314580,
0314581, 0314582, 0314583, 0314584, 0314585, 0314586, 0314587,
0314588, 0314589, 0314590, 0314591, 0314592, 0314593, 0314594,
0314595, 0314596, 0314597, 0314598, 0314599

meets the following basic occupational health and safety of the Machinery Directive 2006/42/EC:

No. 1.1.1, No. 1.1.2, No. 1.1.3, No. 1.1.5, No. 1.3.2, No. 1.5.3, No. 1.5.4, No. 1.5.6, No. 1.5.8, No. 1.5.10, No. 1.5.11, No. 1.5.13

The partly completed machinery may not be put into operation until it has been confirmed that the machine into which the partly completed machinery is to be installed complies with the provisions of the Machinery Directive (2006/42/EC). The declaration shall be rendered invalid if modifications are made to the product.

Applied harmonized standards, especially:

EN ISO 12100:2010 Safety of machinery – General principles for design –
Risk assessment and risk reduction

The special technical documentation according to Annex VII, Part B, belonging to the partly completed machine, has been created.

Person authorized to compile the technical documentation:
Stefanie Walter, Address: see manufacturer's address

Signature: see original declaration

Lauffen/Neckar, February 2024

Dr.-Ing. Manuel Baumeister,
Head of Systems Engineering,
Technology & Innovation

10 UKCA declaration of incorporation

in accordance with the Supply of Machinery (Safety) Regulations 2008.

Manufacturer/
Distributor SCHUNK Intec Limited
 Clamping and gripping technology
 3 Drakes Mews, Crownhill
 MK8 0ER Milton Keynes

We hereby declare that on the date of the declaration the following partly completed machine complied with all basic safety and health regulations found in the "Supply of Machinery (Safety) Regulations 2008".

The declaration shall be rendered invalid if modifications are made to the product.

Product designation: Stroke Module / HLM / pneumatic
ID number 0314574, 0314575, 0314576, 0314577, 0314578, 0314579, 0314580,
 0314581, 0314582, 0314583, 0314584, 0314585, 0314586, 0314587,
 0314588, 0314589, 0314590, 0314591, 0314592, 0314593, 0314594,
 0314595, 0314596, 0314597, 0314598, 0314599

The partly completed machine may not be put into operation until it has been confirmed that the machine into which the partly completed machine is to be installed complies with the provisions of the "Supply of Machinery (Safety) Regulations 2008".

Applied harmonized standards, especially:

EN ISO 12100:2010 Safety of machinery – General principles for design –
 Risk assessment and risk reduction

The special technical documentation according to Annex VII, Part B, belonging to the partly completed machine, has been created.

Person authorized to compile the technical documentation:
Marcel Machado, address: refer to manufacturer's address



Dr.-Ing. Manuel Baumeister,
Head of Systems Engineering,
Technology & Innovation

Lauffen/Neckar, February 2024

11 Information on the RoHS Directive, REACH Regulation and Substances of Very High Concern (SVHC)

RoHS Directive

SCHUNK products are classified as "large-scale stationary installations" or as "large-scale stationary industrial tools" within the meaning of Directive 2011/65/EU and its extension 2015/863/EU "on the restriction of the use of certain hazardous substances in electrical and electronic equipment (RoHS)", or fulfill their intended function only as part of one. Therefore products from SCHUNK do not fall within the scope of the directive at this time.

REACH Regulation

Products from SCHUNK fully comply with the regulations of Regulation (EC) No. 1907/2006 "concerning the Registration, Evaluation, Authorization and Restriction of Chemicals (REACH)" and its amendment 2022/477. SCHUNK attaches great importance to completely avoiding chemicals of concern to humans and the environment wherever possible.

Only in rare exceptional cases do SCHUNK products contain SVHC substances on the candidate list with a mass content above 0.1%. In accordance with Article. 33 (1) of Regulation (EC) No. 1907/2006, SCHUNK complies with its duty to "communicate information on substances in articles" and lists the components concerned and the substances used in an overview that can be viewed at [schunk.com\SVHC](https://www.schunk.com/SVHC).

Signature: see original declaration

Lauffen/Neckar, February 2024

Dr.-Ing. Manuel Baumeister,
Head of Systems Engineering,
Technology & Innovation

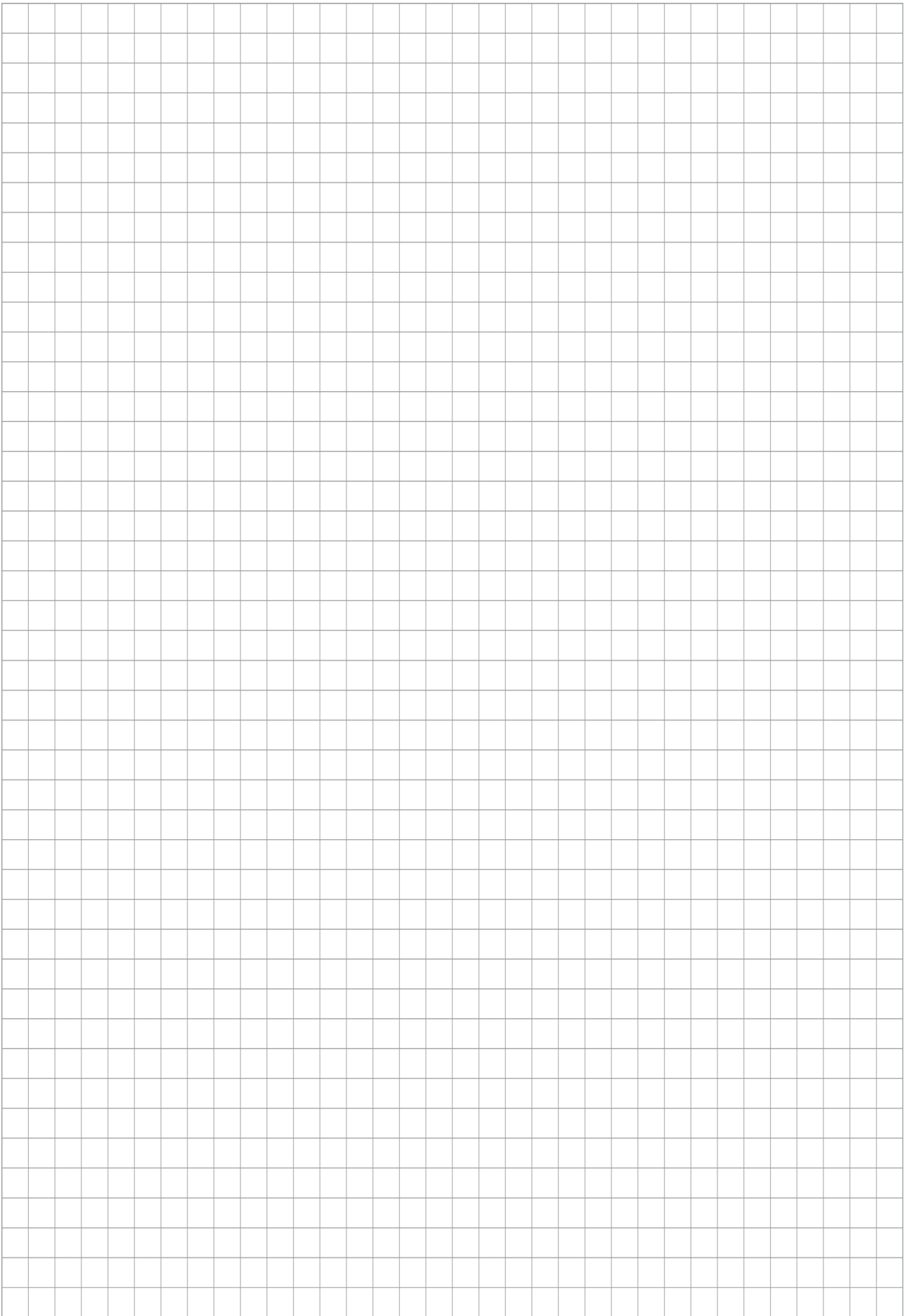



SCHUNK SE & Co. KG
Spanntechnik | Greiftechnik | Automatisierungstechnik

Bahnhofstr. 106 - 134
D-74348 Lauffen/Neckar
Tel. +49-7133-103-0
info@de.schunk.com
schunk.com

Folgen Sie uns | *Follow us*



Wir drucken nachhaltig | *We print sustainable*