

Superior Clamping and Gripping



Product data sheet

Universal rotary unit ERT

ERT

Universal rotary unit

Flat. Dynamic. Precise.

Universal rotary unit ERT

Universal flat rotary unit with absolute encoder and electric brake as well as optional increased protection class (IP54)

Field of application

Universally applicable as a rotary module in handling processes, positioning unit for precise positioning of parts, or as a rotary indexing table. Suitable for clean and slightly dirty environments.



Advantages – Your benefits

Integrated torque drive for high torque and flexible use by controlled position, velocity and torque

Extremely flat design for minimal interfering contours and for use in confined spaces

With absolute position measurement system Less programming effort and time saving when commissioning and in operation

Optionally certified safety devices according to SIL2/PLd with the DRIVE-CliQ interface for applications with high requirements in the area of machine safety

Optional electric brake for maintaining the position in downtime

Large center bore for feed-through lines and media hoses

Versatile actuation options for simple integration into existing control concepts using different external third-party controllers (e.g. Bosch Rexroth IndraDrive or Siemens SINAMICS)

NEW: Due to the single cable technology HIPERFACE DSL®, it saves costs, requires less space and is easy to implement.



Sizes
Quantity: 4



Weight
2.4 .. 25.2 kg



Torque
1.4 .. 32 Nm



Repeat accuracy
0.01°



Angle of rotation
>360°

Functional description

The flat and powerful ERT rotary unit is equipped with a large center bore and is based on an integrated permanently energized torque motor. Positioning is ensured using a cross roller bearing, which is designed for a high

payload. The electric brake is actuated directly via the controller.

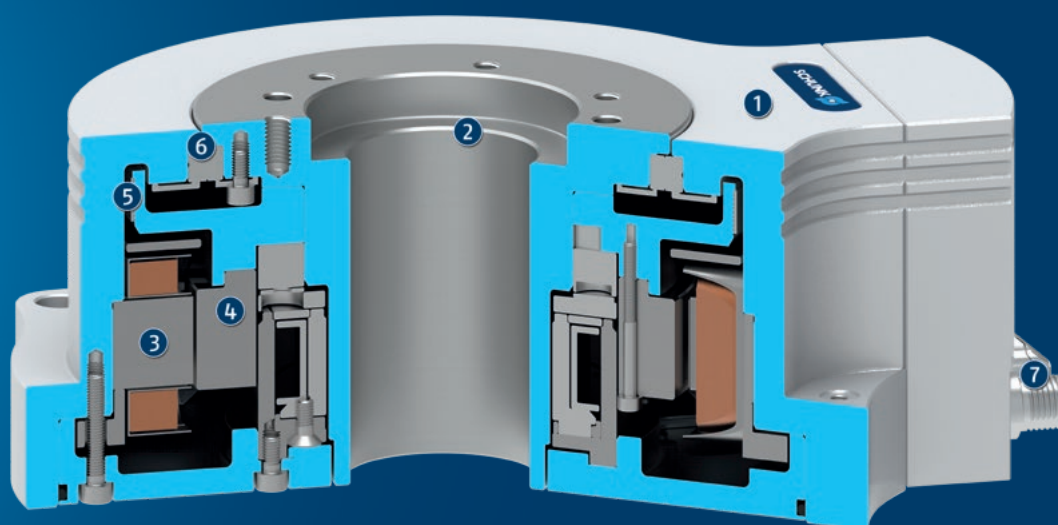

- ① **Housing**
made of die-cast aluminum, compact and flat with low interfering contour
- ② **Rotor with large center bore**
for feeding through supply lines and media
- ③ **Torque motor**
with high torque, flexible RPM, and position control
- ④ **Electric holding brake**
for maintaining the position in downtime
- ⑤ **Magnetic strip**
- ⑥ **Bearing**
very robust, for a high payload
- ⑦ **Connection plug**
for connection of power and encoder cable

Detailed functional description

Centering the structure



The electrical ERT rotary module is suitable for applications with high demands when it comes to axial and radial run-out. For adaptation and correct approval of the run-out, one centering diameter is available. This is visible in the main view. The structure can be prevented from over-rotating using an alignment pin.

- ① ERT in the basic version
- ② Screw connection
- ③ Alignment pin
- ④ Centering groove

Variant with protection class IP54

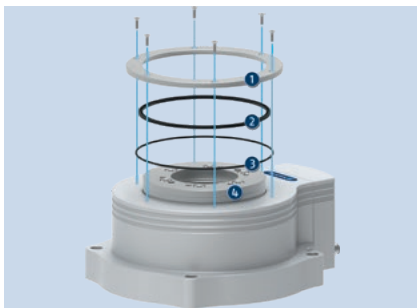

Due to the seals used for IP54 option, the electrical ERT rotary module achieves protection class IP54. For this purpose, an additional set-up is mounted on the ERT rotary table and the seal is fixed using a seal bracket.

- ① Bracket for fastening the sealing
- ② Sealing ring
- ③ O-ring
- ④ Set-up of the rotary table

Flexible choice of drive controller



The rotary module ERT is versatile and can be combined with different drive control systems. With the HIPERFACE® and DRIVE-CLiQ interfaces, connection is made via two standardized plug connectors, separately for motor and encoder cable. With the HIPERFACE DSL® interface, there is only one standardized plug connector combined for motor and encoder. Connection is via a hybrid line. The parameters for the drive controllers shown are included on DVD.

- ① ERT with 560 V motor
- ② Bosch Rexroth IndraDrive Cs controller
- ③ Siemens SINAMICS S120 controller

Ordering example ERT

ERT - 12 - 40 - B - N - H - N

Size

12
50
100
300

IP protection class

IP = 40
IP = 54

Electric holding brake

N = without electric holding brake
B = with electric holding brake

Rotary feed-through

N = without rotary feed-through

Encoder interface

H = HIPERFACE®
D = DRIVE-CLiQ
L = HIPERFACE DSL®

Safety

N = not certified
2 = SIL2/PLd - encoder

General notes about the series

Housing material: Cast aluminum, powder-coated

Drive: Torque motor, 3-phase

Stroke measuring system: Contactless, magnetic measuring system in absolute version; with HIPERFACE® and DRIVE-CLiQ interfaces.

Drive controller: Bosch Rexroth IndraDrive C/Cs or Siemens Sinamics S120 controllers supported as standard; matching parameters supplied on DVD, other manufacturers available on request.

Scope of delivery: Accessory kit with centering sleeves, safety information (product-specific instructions are available online)

Warranty: 24 months

Service life characteristics: on request

Stroke measuring system: Motor-feedback system for absolute measurement, single-turn version, with the HIPERFACE®, HIPERFACE DSL® and DRIVE-CLiQ interfaces

Swiveling times: The swiveling times are purely the times when the module moves from rest position to rest position. Delays caused by the PLC or the drive controller are not included and to be taken into consideration when determining cycle times. Load-dependent rest periods may have to be included in the cycle time.

Layout or control calculation: Verifying the sizing of the selected unit is necessary, since otherwise overloading can result. Please contact us for assistance.

Repeat accuracy: The repeat accuracy is defined as the spread of the target position after 100 consecutive positioning cycles.

Ambient conditions: The modules are primarily designed for the use in clean to slightly contaminated environments. Please note that the life time of the modules can shorten if they are used in harsh ambient conditions, and that SCHUNK cannot assume liability in such cases.

Safety notes: Caution: Magnetic field! This particularly applies for persons with implanted medical devices, such as pacemakers, hearing aids, etc.

Nominal currents: The rated currents can be permanently actuated. With regard to all the currents which are ranging above the nominal current up to the maximum current, the notes of the individual product documentation has to be respected.

Application example

Handling for the reorientation of electrical components in the assembly of cell phones

- 1 Universal rotary unit ERT used as a rotary indexing table and for handling process
- 2 Electric Small Parts Gripper EGP
- 3 Universal linear module LDN
- 4 Universal linear module LDM

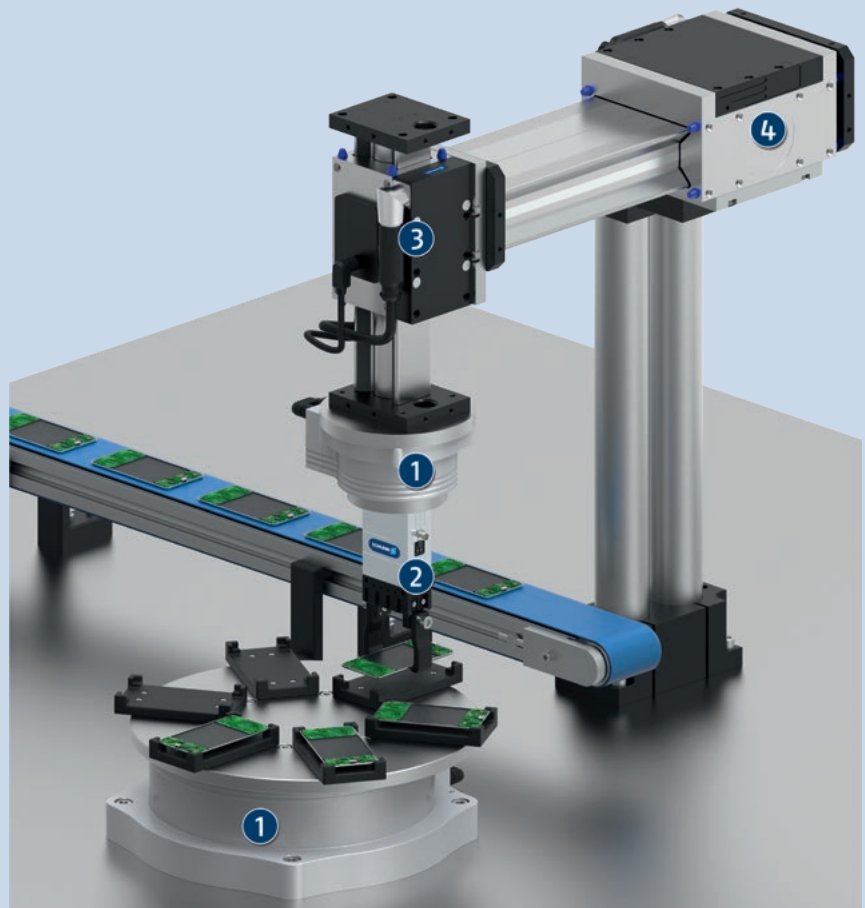

SCHUNK offers more ...

The following components make the product even more productive – the suitable addition for the highest functionality, flexibility, reliability, and controlled production.

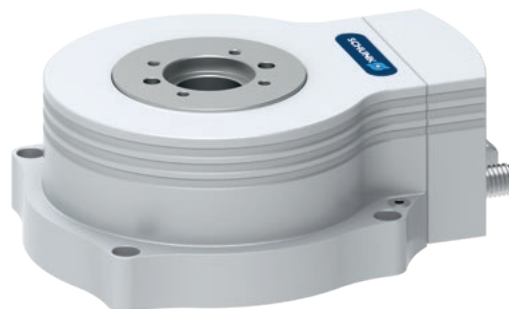

Universal gripper



Long-stroke gripper

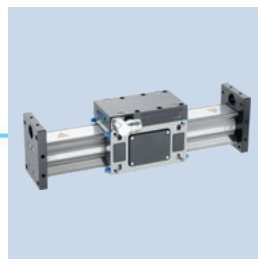

Linear module

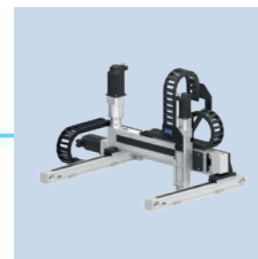

Room gantry



Power and encoder cables

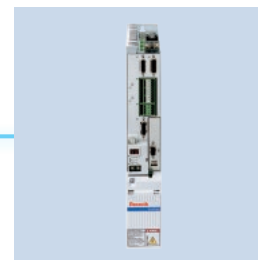

Controller

① For more information on these products can be found on the following product pages or at schunk.com.

Options and special information

Using the electric holding brake: The installed brake is only designed to be used as a holding brake. Consequently, it may only be actuated when stationary. Use as an operating brake is not permitted and significantly increases wear.

Design with IP54 option: With the IP54 option, increased friction is caused by the seals (top and bottom). These have a minor effect on the cycle time in a normal positioning process (< 360°). In this case, the ERT can be designed with the IP54 option in the sizing assistant on the homepage. When used as a rotary drive (continuous rotary movement), the friction of the seals (top and bottom) reduces the available input torque. In this case, additional factors must be taken into account during the design. Please ask for details.

UL certification: The electrical ERT rotary module is partially available with UL certification (certified according to US and Canadian regulations) on request. Please contact us.

Certified encoder system: The encoder system with the DRIVE-CliQ interface is certified according to SIL2/PLd. This means that even demanding applications with high requirements in the area of machine safety can be implemented. Please contact us for further information.

HIPERFACE DSL® encoder interface: The HIPERFACE DSL® encoder interface is a purely digital motor feedback protocol. Due to the single cable technology, it is possible to save costs, it requires less space and it is easy to implement. This interface is currently only supported by the Beckhoff AX8000 drive controller. Please contact us if you would like to use our product with other controllers that support the Hiperface DSL® interface.

ERT 12

Universal rotary unit

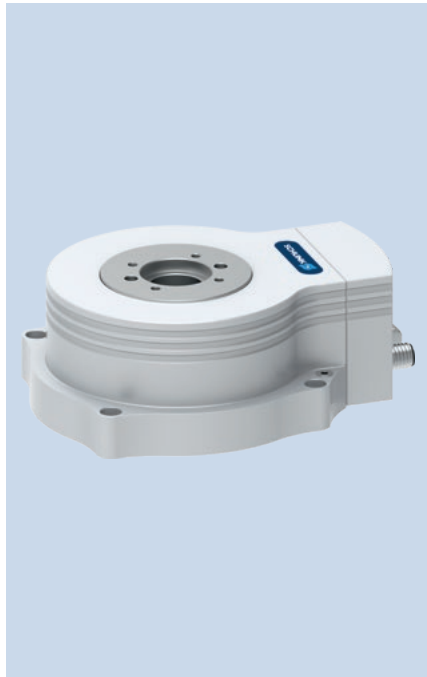

Swivel time diagram

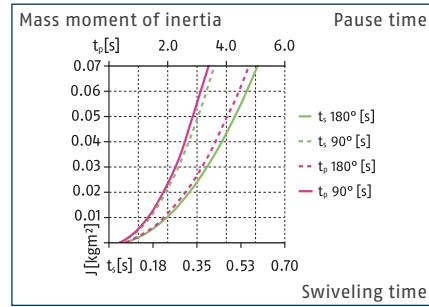

Swivel time diagram IP54

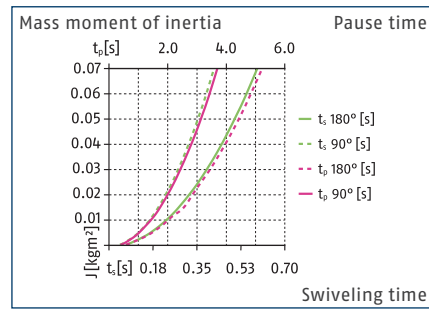

Dimensions and maximum loads

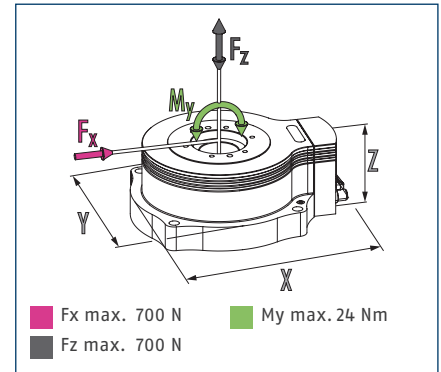

① The indicated forces and moments are maximum values for individual loading. If several forces and/or moments are applied at the same time, the maximum permitted individual values will be lower.

Technical data – HIPERFACE® interface

Description		ERT 12-40-N-N-H-N	ERT 12-40-B-N-H-N	ERT 12-54-N-N-H-N	ERT 12-54-B-N-H-N
ID		1436904	1436905	1461463	1461464
General operating data					
Rated/maximum torque	[Nm]	1.52/4.17	1.4/4.17	1.52/4.17	1.4/4.17
Max. rotational speed	[1/min]	600	600	600	600
Max. permissible mass moment of inertia	[kgm ²]	0.07	0.07	0.07	0.07
Repeat accuracy	[°]	0.01	0.01	0.01	0.01
Radial/axial runout	[mm]	0.02/0.02	0.02/0.02	0.02/0.02	0.02/0.02
Weight	[kg]	2.4	2.7	2.55	2.85
Min./max. ambient temperature	[°C]	5/40	5/40	5/40	5/40
IP protection class		40	40	54	54
Moment holding brake	[Nm]		1.4		1.4
Dimensions X x Y x Z	[mm]	181 x 135 x 64	181 x 135 x 64	181 x 135 x 72	181 x 135 x 72
Electrical operating data					
Intermediate circuit voltage	[V]	560	560	560	560
Rated/maximum current	[A]	1.04/3.27	0.96/3.27	1.04/3.27	0.96/3.27
Encoder system		Encoder (absolute)	Encoder (absolute)	Encoder (absolute)	Encoder (absolute)
Output signal		HIPERFACE®	HIPERFACE®	HIPERFACE®	HIPERFACE®
SIL certification		not certified	not certified	not certified	not certified

- ① The peak torques serve as short-term drive reserves when accelerating and delaying.
- ② Swivel and pause times apply for motions without restricted speeds at max. current. Reducing the max. current increases swivel periods and reduces rest periods. Higher mass moments of inertia are possible. Diagrams only apply for sufficiently rigid designs. Please contact us for assistance with the design of your application.

Technical data – HIPERFACE-DSL® interface

Description		ERT 12-40-N-N-L-N	ERT 12-40-B-N-L-N	ERT 12-54-N-N-L-N	ERT 12-54-B-N-L-N
ID		1529428	1529440	1529429	1529441
General operating data					
Rated/maximum torque	[Nm]	1.52/4.17	1.4/4.17	1.52/4.17	1.4/4.17
Max. rotational speed	[1/min]	600	600	600	600
Max. permissible mass moment of inertia	[kgm ²]	0.07	0.07	0.07	0.07
Repeat accuracy	[°]	0.01	0.01	0.01	0.01
Radial/axial runout	[mm]	0.02/0.02	0.02/0.02	0.02/0.02	0.02/0.02
Weight	[kg]	2.4	2.7	2.55	2.85
Min./max. ambient temperature	[°C]	5/40	5/40	5/40	5/40
IP protection class		40	40	54	54
Moment holding brake	[Nm]		1.4		1.4
Dimensions X x Y x Z	[mm]	181 x 135 x 64	181 x 135 x 64	181 x 135 x 72	181 x 135 x 72
Electrical operating data					
Intermediate circuit voltage	[V]	560	560	560	560
Rated/maximum current	[A]	1.04/3.27	0.96/3.27	1.04/3.27	0.96/3.27
Encoder system		Encoder (absolute)	Encoder (absolute)	Encoder (absolute)	Encoder (absolute)
Output signal		HIPERFACE DSL®	HIPERFACE DSL®	HIPERFACE DSL®	HIPERFACE DSL®
SIL certification		not certified	not certified	not certified	not certified

① The peak torques serve as short-term drive reserves when accelerating and delaying.

① Swivel and pause times apply for motions without restricted speeds at max. current. Reducing the max. current increases swivel periods and reduces rest periods. Higher mass moments of inertia are possible. Diagrams only apply for sufficiently rigid designs. Please contact us for assistance with the design of your application.

Technical data – DRIVE-CLiQ interface

Description		ERT 12-40-N-N-D-N	ERT 12-40-B-N-D-N	ERT 12-54-N-N-D-N	ERT 12-54-B-N-D-N
ID		1461462	1459481	1461465	1461466
General operating data					
Rated/maximum torque	[Nm]	1.52/4.17	1.4/4.17	1.52/4.17	1.4/4.17
Max. rotational speed	[1/min]	600	600	600	600
Max. permissible mass moment of inertia	[kgm ²]	0.07	0.07	0.07	0.07
Repeat accuracy	[°]	0.01	0.01	0.01	0.01
Radial/axial runout	[mm]	0.02/0.02	0.02/0.02	0.02/0.02	0.02/0.02
Weight	[kg]	2.4	2.7	2.55	2.85
Min./max. ambient temperature	[°C]	5/40	5/40	5/40	5/40
IP protection class		40	40	54	54
Moment holding brake	[Nm]		1.4		1.4
Dimensions X x Y x Z	[mm]	181 x 135 x 64	181 x 135 x 64	181 x 135 x 72	181 x 135 x 72
Electrical operating data					
Intermediate circuit voltage	[V]	560	560	560	560
Rated/maximum current	[A]	1.04/3.27	0.96/3.27	1.04/3.27	0.96/3.27
Encoder system		Encoder (absolute)	Encoder (absolute)	Encoder (absolute)	Encoder (absolute)
Output signal		DRIVE-CLiQ	DRIVE-CLiQ	DRIVE-CLiQ	DRIVE-CLiQ
SIL certification		not certified	not certified	not certified	not certified
Options and their characteristics					
Version with SIL certification		ERT 12-40-N-N-D-2	ERT 12-40-B-N-D-2	ERT 12-54-N-N-D-2	ERT 12-54-B-N-D-2
ID		1481989	1482031	1482032	1482051
SIL certification		2	2	2	2

① The peak torques serve as short-term drive reserves when accelerating and delaying.

① Swivel and pause times apply for motions without restricted speeds at max. current. Reducing the max. current increases swivel periods and reduces rest periods. Higher mass moments of inertia are possible. Diagrams only apply for sufficiently rigid designs. Please contact us for assistance with the design of your application.

Power cable

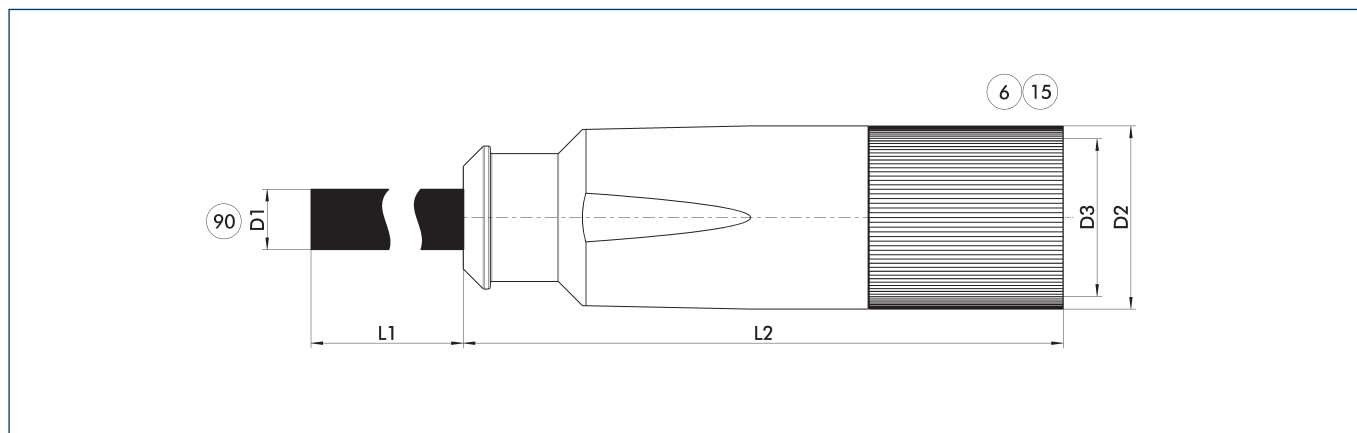

Connection cables such as power cables and encoder cables are specifically designed for connecting SCHUNK products with drive control units. We will gladly help you to select the right connection cables.

⑥ Connection module side
⑮ Socket

⑨⑩ Prefabricated to connect to the higher-level components

Description	ID	L1 [m]	D1 [mm]	L2 [mm]	D2 [mm]	D3
Power cable for BOSCH Rexroth IndraDrive Cs – cable track-compatible						
KA GLT1708-LK-00500-C	1420596	5	11	55	21.1	M17
KA GLT1708-LK-01000-C	1420607	10	11	55	21.1	M17
KA GLT1708-LK-01500-C	1436382	15	11	55	21.1	M17
KA GLT1708-LK-02000-C	1436389	20	11	55	21.1	M17
Power cable for Siemens SINAMICS with DRIVE-CLiQ – cable track compatible						
ERT - DQ 05m	1462959	5	11	55	21.1	M17
ERT - DQ 10m	1462964	10	11	55	21.1	M17
ERT - DQ 15m	1462967	15	11	55	21.1	M17
ERT - DQ 20m	1462969	20	11	55	21.1	M17

① Please observe the min. bending radius for cable track-compatible cables or the max. torsion angle for torsion-compatible cables. These are generally 10 times the cable diameter or +/- 180°/m.

Encoder cable

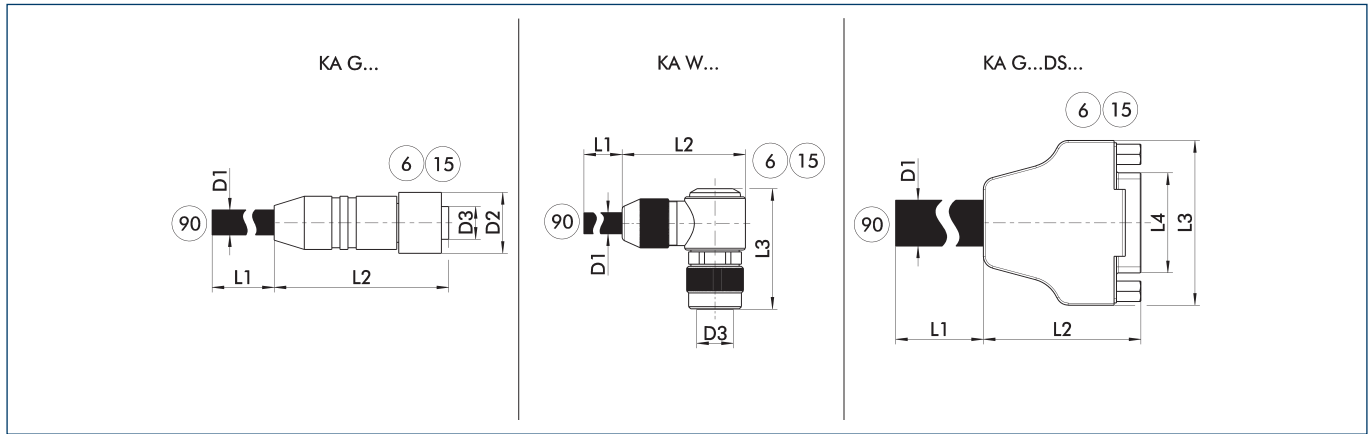

KA G... encoder cable with straight plug
 KA W... encoder cable with angled plug
 KA G...DS... Sub D encoder cable

⑥ Connection module side
 ⑬ Socket
 ⑨⑩ Prefabricated for connection to the drive controller

Connection cables such as power cables and encoder cables are specifically designed for connecting SCHUNK products with drive control units. We will gladly help you to select the right connection cables.

Description	ID	L1	D1	L2	D2	L3	D3
		[m]	[mm]	[mm]	[mm]	[mm]	
Encoder cable for BOSCH IndraDrive A/B/Cs and HIPERFACE® encoder interface – drag chain compatible							
KA WWN1208-GK-00500-K	0349544	5	6	37.5	14.9	30.8	M12
KA WWN1208-GK-01000-K	0349545	10	6	37.5	14.9	30.8	M12
KA WWN1208-GK-01500-K	0349546	15	6	37.5	14.9	30.8	M12
KA WWN1208-GK-02000-K	0349547	20	6	37.5	14.9	30.8	M12
Sensor cable for Siemens SINAMICS and encoder interface DRIVE-CLiQ – cable track compatible							
ERD/ERT - DQ 05m	1395066	5	6	37.5	14.9	30.8	M12
ERD/ERT - DQ 10m	1395071	10	6	37.5	14.9	30.8	M12
ERD/ERT - DQ 15m	1388995	15	6	37.5	14.9	30.8	M12
ERD/ERT - DQ 20m	1395076	20	6	37.5	14.9	30.8	M12

ⓘ Please observe the min. bending radius for cable track-compatible cables or the max. torsion angle for torsion-compatible cables. These are generally 10 times the cable diameter or +/- 180°/m.

Hybrid cable

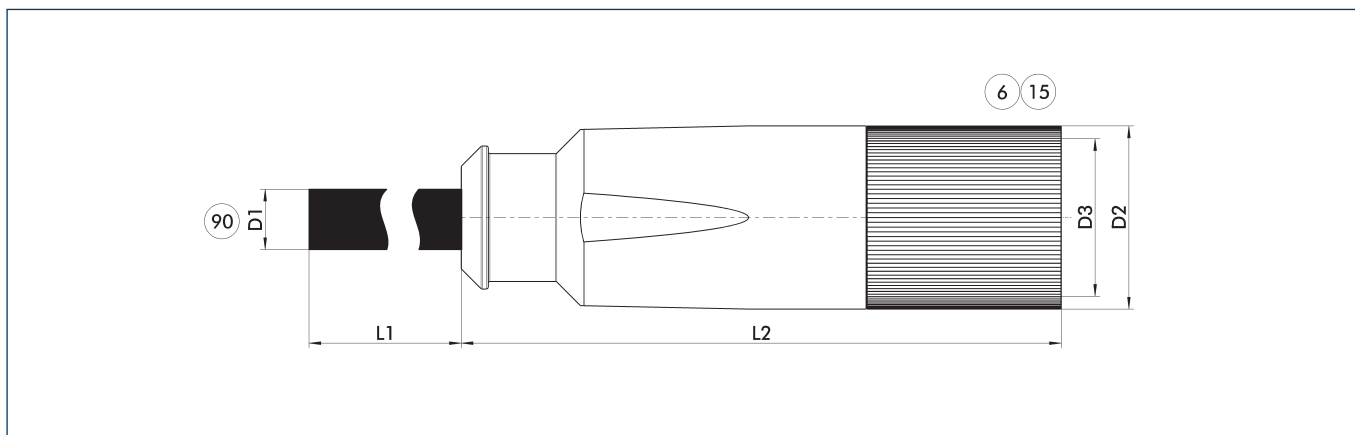

Connection cables such as power cables and encoder cables are specifically designed for connecting SCHUNK products with drive control units. We will gladly help you to select the right connection cables.

- ⑥ Connection module side
- ⑮ Socket

- ⑨⑩ Prefabricated to connect to the higher-level components

Description	ID	L1	D1	L2	D2	D3
		[m]	[mm]	[mm]	[mm]	
Hybrid cable						
ERT - HiperfaceDSL 05m	1528548	5	11	55	21.1	M17
ERT - HiperfaceDSL 10m	1528550	10	11	55	21.1	M17
ERT - HiperfaceDSL 15m	1528552	15	11	55	21.1	M17
ERT - HiperfaceDSL 20m	1528553	20	11	55	21.1	M17

① Please observe the min. bending radius for cables suitable for drag chain applications and the max. torsion angle for torsion-compatible cables. These are generally ten times the cable diameter or $\pm 180^\circ/m$. Please note additionally that the hybrid cables can only be used in conjunction with a drive controller that supports the Hiperface DSL® interface. This interface is currently only supported by the Beckhoff AX8000 drive controller. Please contact us if you would like to use our product with other controllers that support the Hiperface DSL® interface.

Bosch Rexroth IndraDrive Cs controller

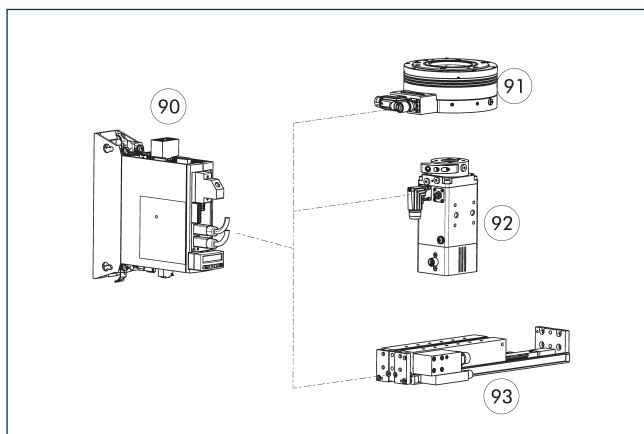

- ⑨⑩ Controller
- ⑨① Rotary module ERS/ERT, electric
- ⑨② ERD Rotary unit
- ⑨③ Compact linear module ELB

The controller can be used to operate the rotary modules ERS, ERT and ERD as well as for SCHUNK linear motor axes. It is available with the PROFIBUS or Multi-Ethernet (Sercos III, PROFINET, EtherCAT, EtherNet/IP) communication interfaces.

Description	Nominal current	Maximum current	Note
	[A]	[A]	
Controller			
HCS01.1E-W0008	2.7	8	

① We will be happy to help you select the right controller. Please contact us for assistance.

ERT 50

Universal rotary unit

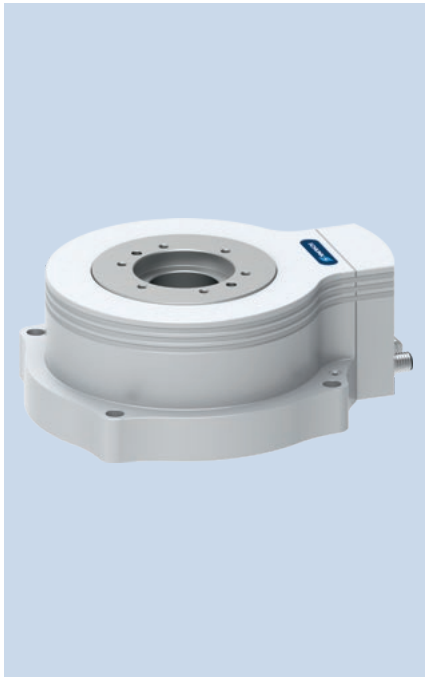

Swivel time diagram

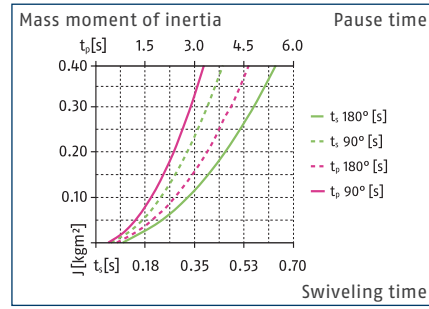

Swivel time diagram IP54

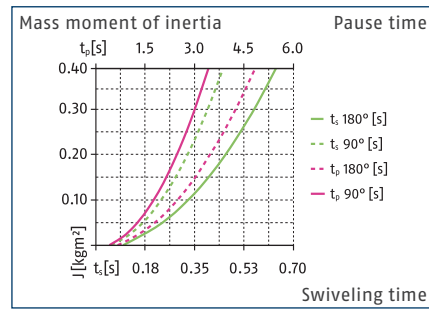

Dimensions and maximum loads

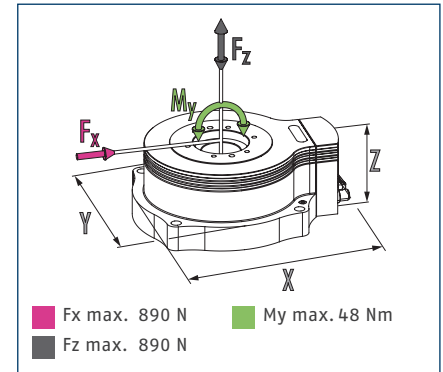

① The indicated forces and moments are maximum values for individual loading. If several forces and/or moments are applied at the same time, the maximum permitted individual values will be lower.

Technical data – HIPERFACE® interface

Description		ERT 50-40-N-N-H-N	ERT 50-40-B-N-H-N	ERT 50-54-N-N-H-N	ERT 50-54-B-N-H-N
ID		1436906	1436907	1461468	1461469
General operating data					
Rated/maximum torque	[Nm]	7.8/20.1	7.04/20.1	7.8/20.1	7.04/20.1
Max. rotational speed	[1/min]	350	350	350	350
Max. permissible mass moment of inertia	[kgm ²]	0.39	0.39	0.39	0.39
Repeat accuracy	[°]	0.01	0.01	0.01	0.01
Radial/axial runout	[mm]	0.05/0.05	0.05/0.05	0.05/0.05	0.05/0.05
Weight	[kg]	5.74	6.46	6.12	6.84
Min./max. ambient temperature	[°C]	5/40	5/40	5/40	5/40
IP protection class		40	40	54	54
Moment holding brake	[Nm]		7.04		7.04
Dimensions X x Y x Z	[mm]	235 x 190 x 85	235 x 190 x 85	235 x 190 x 97	235 x 190 x 97
Electrical operating data					
Intermediate circuit voltage	[V]	560	560	560	560
Rated/maximum current	[A]	2.7/8.54	2.44/8.54	2.7/8.54	2.44/8.54
Encoder system		Encoder (absolute)	Encoder (absolute)	Encoder (absolute)	Encoder (absolute)
Output signal		HIPERFACE®	HIPERFACE®	HIPERFACE®	HIPERFACE®
SIL certification		not certified	not certified	not certified	not certified

① The peak torques serve as short-term drive reserves when accelerating and delaying.

② Swivel and pause times apply for motions without restricted speeds at max. current. Reducing the max. current increases swivel periods and reduces rest periods. Higher mass moments of inertia are possible. Diagrams only apply for sufficiently rigid designs. Please contact us for assistance with the design of your application.

Technical data – HIPERFACE-DSL® interface

Description		ERT 50-40-N-N-L-N	ERT 50-40-B-N-L-N	ERT 50-54-N-N-L-N	ERT 50-54-B-N-L-N
ID		1529442	1529444	1529443	1529445
General operating data					
Rated/maximum torque	[Nm]	7.8/20.1	7.04/20.1	7.8/20.1	7.04/20.1
Max. rotational speed	[1/min]	350	350	350	350
Max. permissible mass moment of inertia	[kgm ²]	0.39	0.39	0.39	0.39
Repeat accuracy	[°]	0.01	0.01	0.01	0.01
Radial/axial runout	[mm]	0.05/0.05	0.05/0.05	0.05/0.05	0.05/0.05
Weight	[kg]	5.7	6.4	6.84	6.84
Min./max. ambient temperature	[°C]	5/40	5/40	5/40	5/40
IP protection class		40	40	54	54
Moment holding brake	[Nm]		7.04		7.04
Dimensions X x Y x Z	[mm]	235 x 190 x 85	235 x 190 x 85	235 x 190 x 97	235 x 190 x 97
Electrical operating data					
Intermediate circuit voltage	[V]	560	560	560	560
Rated/maximum current	[A]	2.7/8.54	2.44/8.54	2.7/8.54	2.44/8.54
Encoder system		Encoder (absolute)	Encoder (absolute)	Encoder (absolute)	Encoder (absolute)
Output signal		HIPERFACE DSL®	HIPERFACE DSL®	HIPERFACE DSL®	HIPERFACE DSL®
SIL certification		not certified	not certified	not certified	not certified

① The peak torques serve as short-term drive reserves when accelerating and delaying.

① Swivel and pause times apply for motions without restricted speeds at max. current. Reducing the max. current increases swivel periods and reduces rest periods. Higher mass moments of inertia are possible. Diagrams only apply for sufficiently rigid designs. Please contact us for assistance with the design of your application.

Technical data – DRIVE-CLiQ interface

Description		ERT 50-40-N-N-D-N	ERT 50-40-B-N-D-N	ERT 50-54-N-N-D-N	ERT 50-54-B-N-D-N
ID		1459378	1461467	1461500	1461501
General operating data					
Rated/maximum torque	[Nm]	7.8/20.1	7.04/20.1	7.8/20.1	7.04/20.1
Max. rotational speed	[1/min]	350	350	350	350
Max. permissible mass moment of inertia	[kgm ²]	0.39	0.39	0.39	0.39
Repeat accuracy	[°]	0.01	0.01	0.01	0.01
Radial/axial runout	[mm]	0.05/0.05	0.05/0.05	0.05/0.05	0.05/0.05
Weight	[kg]	5.74	6.46	6.12	6.84
Min./max. ambient temperature	[°C]	5/40	5/40	5/40	5/40
IP protection class		40	40	54	54
Moment holding brake	[Nm]		7.04		7.04
Dimensions X x Y x Z	[mm]	235 x 190 x 85	235 x 190 x 85	235 x 190 x 97	235 x 190 x 97
Electrical operating data					
Intermediate circuit voltage	[V]	560	560	560	560
Rated/maximum current	[A]	2.7/8.54	2.44/8.54	2.7/8.54	2.44/8.54
Encoder system		Encoder (absolute)	Encoder (absolute)	Encoder (absolute)	Encoder (absolute)
Output signal		DRIVE-CLiQ	DRIVE-CLiQ	DRIVE-CLiQ	DRIVE-CLiQ
SIL certification		not certified	not certified	not certified	not certified
Options and their characteristics					
Version with SIL certification		ERT 50-40-N-N-D-2	ERT 50-40-B-N-D-2	ERT 50-54-N-N-D-2	ERT 50-54-B-N-D-2
ID		1482053	1482054	1482055	1482056
SIL certification		2	2	2	2

① The peak torques serve as short-term drive reserves when accelerating and delaying.

① Swivel and pause times apply for motions without restricted speeds at max. current. Reducing the max. current increases swivel periods and reduces rest periods. Higher mass moments of inertia are possible. Diagrams only apply for sufficiently rigid designs. Please contact us for assistance with the design of your application.

ERT 50

Universal rotary unit

Main view

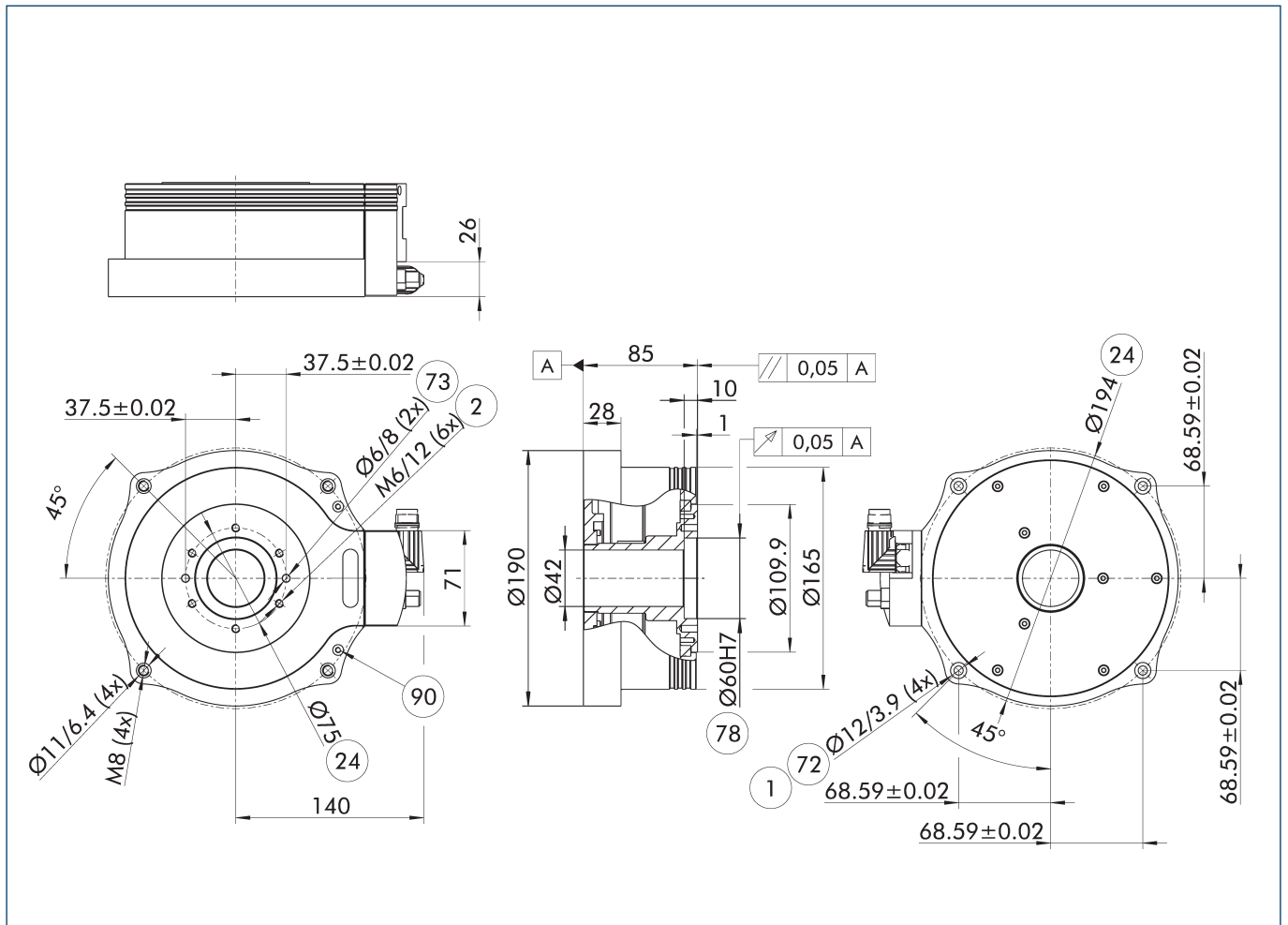

- ① Connection swivel unit
- ② Attachment connection
- ④ Bolt circle
- ⑦ Fit for centering sleeves
- ⑦③ Fit for centering pins
- ⑦⑧ Fit for centering
- ⑨① Ground connection

View for protection class IP54

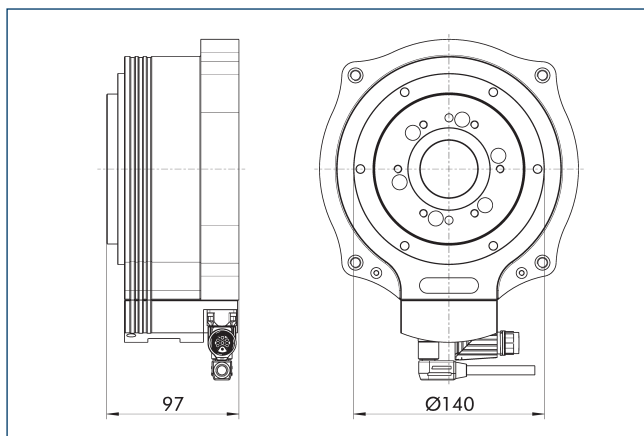

The view shows the height of the ERT with protection class IP54.

View for HIPERFACE DSL®

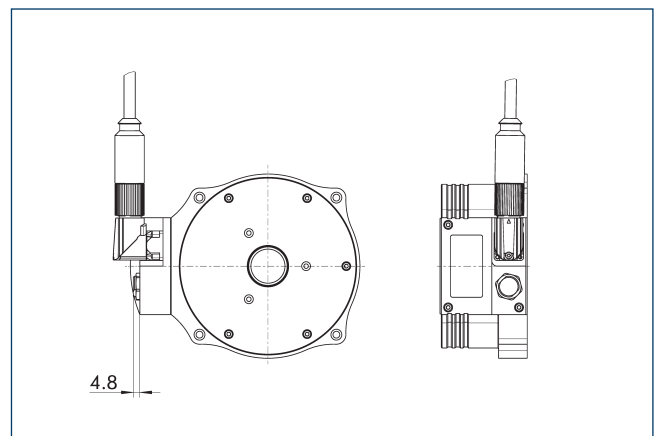

The view shows the ERT with the single-cable technology HIPERFACE DSL®.

Power cable

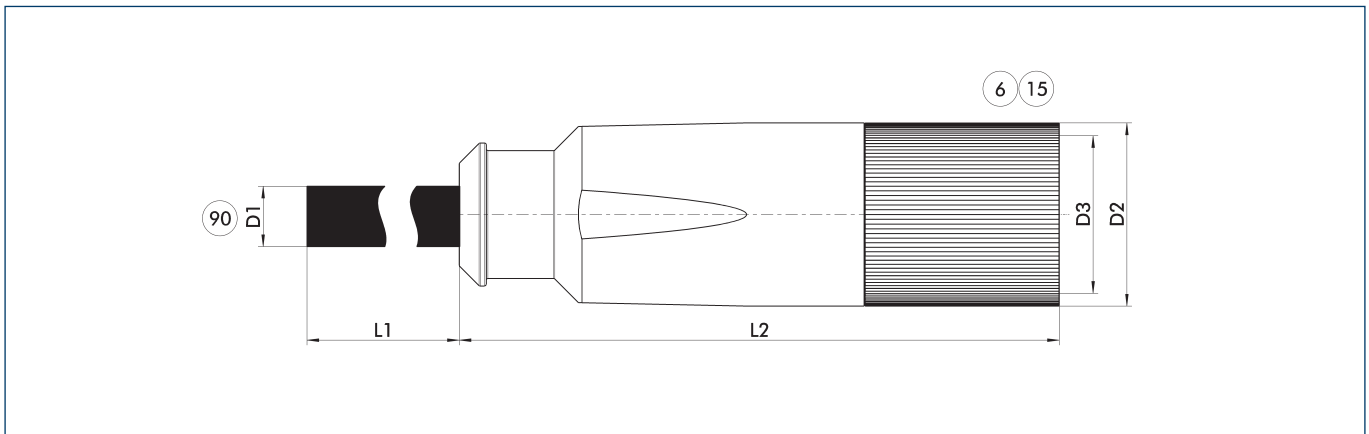

Connection cables such as power cables and encoder cables are specifically designed for connecting SCHUNK products with drive control units. We will gladly help you to select the right connection cables.

⑥ Connection module side
⑮ Socket

⑨⑩ Prefabricated to connect to the higher-level components

Description	ID	L1 [m]	D1 [mm]	L2 [mm]	D2 [mm]	D3
Power cable for BOSCH Rexroth IndraDrive Cs – cable track-compatible						
KA GLT1708-LK-00500-C	1420596	5	11	55	21.1	M17
KA GLT1708-LK-01000-C	1420607	10	11	55	21.1	M17
KA GLT1708-LK-01500-C	1436382	15	11	55	21.1	M17
KA GLT1708-LK-02000-C	1436389	20	11	55	21.1	M17
Power cable for Siemens SINAMICS with DRIVE-CLiQ – cable track compatible						
ERT - DQ 05m	1462959	5	11	55	21.1	M17
ERT - DQ 10m	1462964	10	11	55	21.1	M17
ERT - DQ 15m	1462967	15	11	55	21.1	M17
ERT - DQ 20m	1462969	20	11	55	21.1	M17

① Please observe the min. bending radius for cable track-compatible cables or the max. torsion angle for torsion-compatible cables. These are generally 10 times the cable diameter or +/- 180°/m.

ERT 50

Universal rotary unit

Encoder cable

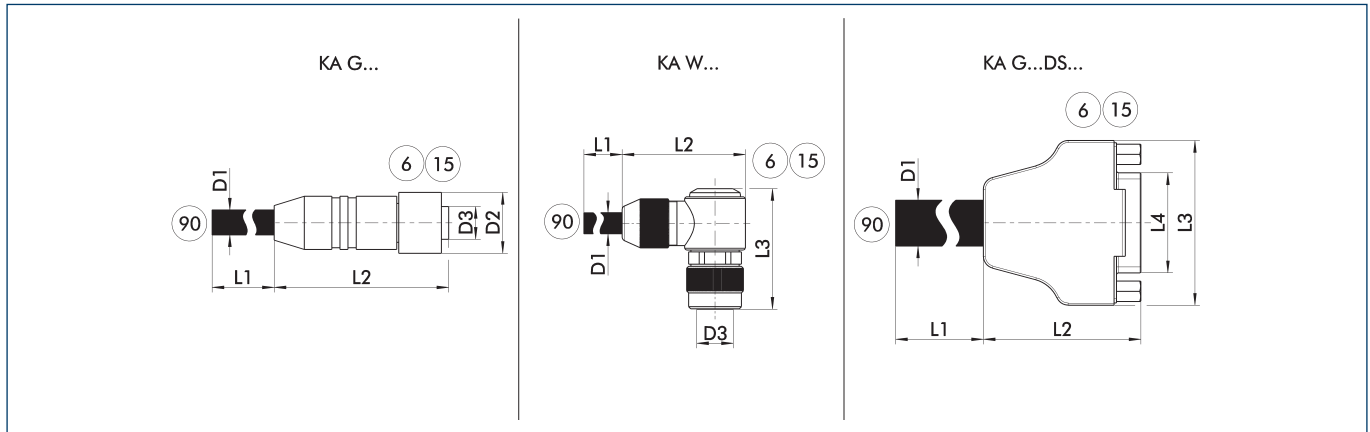

KA G... encoder cable with straight plug
 KA W... encoder cable with angled plug
 KA G...DS... Sub D encoder cable

⑥ Connection module side
 ⑮ Socket
 ⑨⑩ Prefabricated for connection to the drive controller

Connection cables such as power cables and encoder cables are specifically designed for connecting SCHUNK products with drive control units. We will gladly help you to select the right connection cables.

Description	ID	L1	D1	L2	D2	L3	D3
		[m]	[mm]	[mm]	[mm]	[mm]	
Encoder cable for BOSCH IndraDrive A/B/Cs and HIPERFACE® encoder interface – drag chain compatible							
KA WWN1208-GK-00500-K	0349544	5	6	37.5	14.9	30.8	M12
KA WWN1208-GK-01000-K	0349545	10	6	37.5	14.9	30.8	M12
KA WWN1208-GK-01500-K	0349546	15	6	37.5	14.9	30.8	M12
KA WWN1208-GK-02000-K	0349547	20	6	37.5	14.9	30.8	M12
Sensor cable for Siemens SINAMICS and encoder interface DRIVE-CLiQ – cable track compatible							
ERD/ERT - DQ 05m	1395066	5	6	37.5	14.9	30.8	M12
ERD/ERT - DQ 10m	1395071	10	6	37.5	14.9	30.8	M12
ERD/ERT - DQ 15m	1388995	15	6	37.5	14.9	30.8	M12
ERD/ERT - DQ 20m	1395076	20	6	37.5	14.9	30.8	M12

ⓘ Please observe the min. bending radius for cable track-compatible cables or the max. torsion angle for torsion-compatible cables. These are generally 10 times the cable diameter or +/- 180°/m.

Hybrid cable

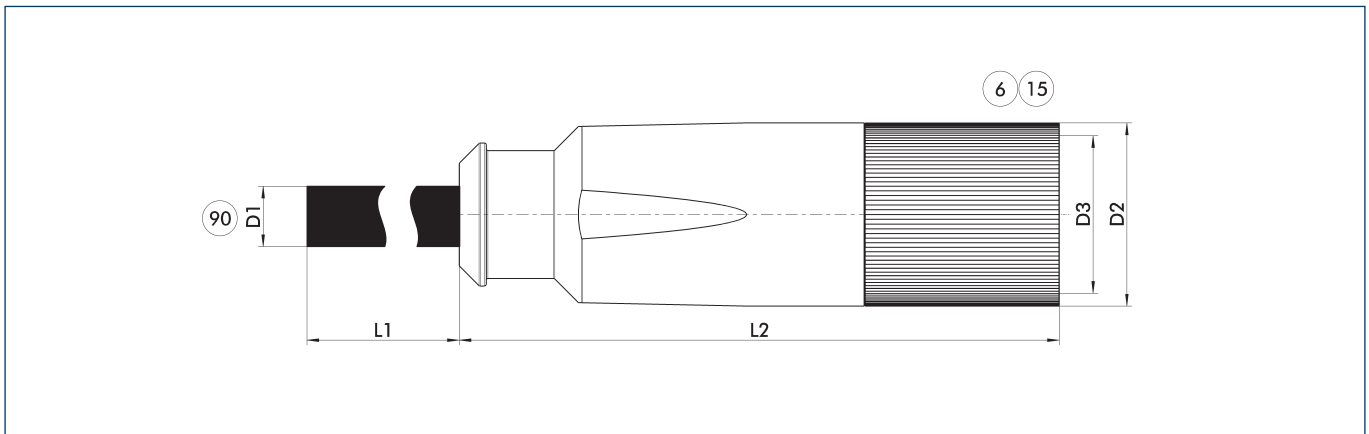

Connection cables such as power cables and encoder cables are specifically designed for connecting SCHUNK products with drive control units. We will gladly help you to select the right connection cables.

- ⑥ Connection module side
- ⑮ Socket

- ⑨⑩ Prefabricated to connect to the higher-level components

Description	ID	L1	D1	L2	D2	D3
		[m]	[mm]	[mm]	[mm]	
Hybrid cable						
ERT - HiperfaceDSL 05m	1528548	5	11	55	21.1	M17
ERT - HiperfaceDSL 10m	1528550	10	11	55	21.1	M17
ERT - HiperfaceDSL 15m	1528552	15	11	55	21.1	M17
ERT - HiperfaceDSL 20m	1528553	20	11	55	21.1	M17

① Please observe the min. bending radius for cables suitable for drag chain applications and the max. torsion angle for torsion-compatible cables. These are generally ten times the cable diameter or $\pm 180^\circ/m$. Please note additionally that the hybrid cables can only be used in conjunction with a drive controller that supports the Hiperface DSL® interface. This interface is currently only supported by the Beckhoff AX8000 drive controller. Please contact us if you would like to use our product with other controllers that support the Hiperface DSL® interface.

Bosch Rexroth IndraDrive Cs controller

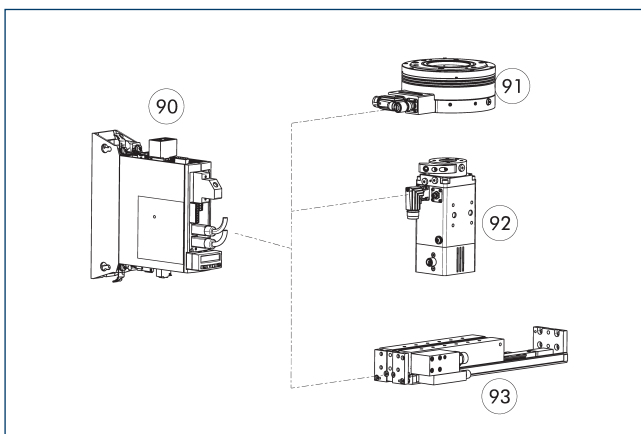

- ⑨⑩ Controller
- ⑨① Rotary module ERS/ERT, electric
- ⑨② ERD Rotary unit
- ⑨③ Compact linear module ELB

The controller can be used to operate the rotary modules ERS, ERT and ERD as well as for SCHUNK linear motor axes. It is available with the PROFIBUS or Multi-Ethernet (Sercos III, PROFINET, EtherCAT, EtherNet/IP) communication interfaces.

Description	Nominal current	Maximum current	Note
	[A]	[A]	
Controller			
HCS01.1E-W0008	2.7	8	

① We will be happy to help you select the right controller. Please contact us for assistance.

ERT 100

Universal rotary unit



Swivel time diagram

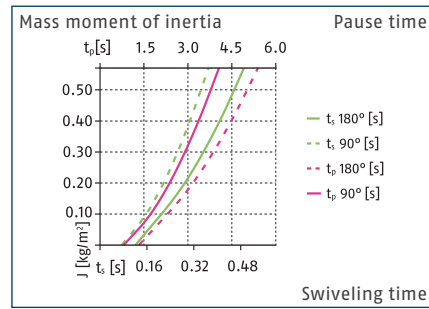

Swivel time diagram IP54

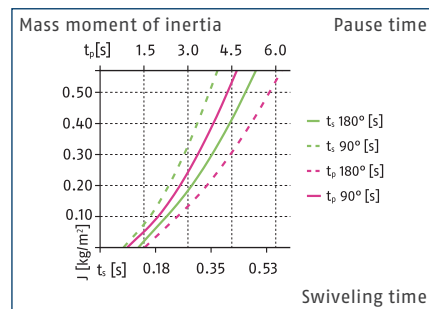

Dimensions and maximum loads

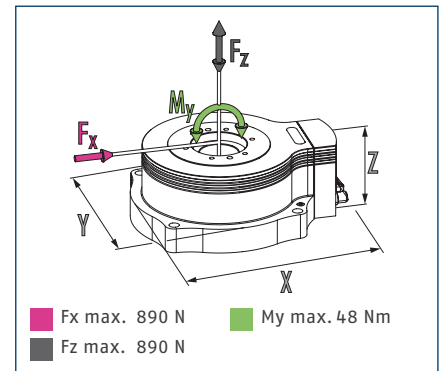

① The indicated forces and moments are maximum values for individual loading. If several forces and/or moments are applied at the same time, the maximum permitted individual values will be lower.

Technical data – HIPERFACE® interface

Description		ERT 100-40-N-N-H-N	ERT 100-40-B-N-H-N	ERT 100-54-N-N-H-N	ERT 100-54-B-N-H-N
ID		1529406	1529408	1529407	1529409
General operating data					
Rated/maximum torque	[Nm]	16.7/51	14/51	16.7/51	14/51
Max. rotational speed	[1/min]	350	350	350	350
Max. permissible mass moment of inertia	[kgm²]	0.57	0.57	0.57	0.57
Repeat accuracy	[°]	0.01	0.01	0.01	0.01
Radial/axial runout	[mm]	0.05/0.05	0.05/0.05	0.05/0.05	0.05/0.05
Weight	[kg]	7.8	8.8	7.84	8.84
Min./max. ambient temperature	[°C]	5/40	5/40	5/40	5/40
IP protection class		40	40	54	54
Moment holding brake	[Nm]		17		17
Dimensions X x Y x Z	[mm]	235 x 190 x 108	235 x 190 x 108	235 x 190 x 120	235 x 190 x 120
Electrical operating data					
Intermediate circuit voltage	[V]	560	560	560	560
Rated/maximum current	[A]	2.56/7.61	2.41/7.61	2.41/7.61	2.41/7.61
Encoder system		Encoder (absolute)	Encoder (absolute)	Encoder (absolute)	Encoder (absolute)
Output signal		HIPERFACE®	HIPERFACE®	HIPERFACE®	HIPERFACE®
SIL certification		not certified	not certified	not certified	not certified

- ① The peak torques serve as short-term drive reserves when accelerating and delaying.
- ② Swivel and pause times apply for motions without restricted speeds at max. current. Reducing the max. current increases swivel periods and reduces rest periods. Higher mass moments of inertia are possible. Diagrams only apply for sufficiently rigid designs. Please contact us for assistance with the design of your application.

Technical data – HIPERFACE-DSL® interface

Description		ERT 100-40-N-N-L-N	ERT 100-40-B-N-L-N	ERT 100-54-N-N-L-N	ERT 100-54-B-N-L-N
ID		1529446	1529448	1529447	1529449
General operating data					
Rated/maximum torque	[Nm]	16.7/51	14/51	16.7/51	14/51
Max. rotational speed	[1/min]	350	350	350	350
Max. permissible mass moment of inertia	[kgm ²]	0.57	0.57	0.57	0.57
Repeat accuracy	[°]	0.01	0.01	0.01	0.01
Radial/axial runout	[mm]	0.05/0.05	0.05/0.05	0.05/0.05	0.05/0.05
Weight	[kg]	7.8	8.8	7.84	8.84
Min./max. ambient temperature	[°C]	5/40	5/40	5/40	5/40
IP protection class		40	40	54	54
Moment holding brake	[Nm]		17		17
Dimensions X x Y x Z	[mm]	235 x 190 x 108	235 x 190 x 108	235 x 190 x 120	235 x 190 x 120
Electrical operating data					
Intermediate circuit voltage	[V]	560	560	560	560
Rated/maximum current	[A]	2.56/7.61	2.41/7.61	2.41/7.61	2.41/7.61
Encoder system		Encoder (absolute)	Encoder (absolute)	Encoder (absolute)	Encoder (absolute)
Output signal		HIPERFACE DSL®	HIPERFACE DSL®	HIPERFACE DSL®	HIPERFACE DSL®
SIL certification		not certified	not certified	not certified	not certified

① The peak torques serve as short-term drive reserves when accelerating and delaying.

① Swivel and pause times apply for motions without restricted speeds at max. current. Reducing the max. current increases swivel periods and reduces rest periods. Higher mass moments of inertia are possible. Diagrams only apply for sufficiently rigid designs. Please contact us for assistance with the design of your application.

Technical data – DRIVE-CLiQ interface

Description		ERT 100-40-N-N-D-N	ERT 100-40-B-N-D-N	ERT 100-54-N-N-D-N	ERT 100-54-B-N-D-N
ID		1529420	1529422	1529421	1529423
General operating data					
Rated/maximum torque	[Nm]	16.7/51	14/51	16.7/51	14/51
Max. rotational speed	[1/min]	350	350	350	350
Max. permissible mass moment of inertia	[kgm ²]	0.57	0.57	0.57	0.57
Repeat accuracy	[°]	0.01	0.01	0.01	0.01
Radial/axial runout	[mm]	0.05/0.05	0.05/0.05	0.05/0.05	0.05/0.05
Weight	[kg]	7.8	8.8	7.84	8.84
Min./max. ambient temperature	[°C]	5/40	5/40	5/40	5/40
IP protection class		40	40	54	54
Moment holding brake	[Nm]		17		17
Dimensions X x Y x Z	[mm]	235 x 190 x 108	235 x 190 x 108	235 x 190 x 120	235 x 190 x 120
Electrical operating data					
Intermediate circuit voltage	[V]	560	560	560	560
Rated/maximum current	[A]	2.56/7.61	2.41/7.61	2.41/7.61	2.41/7.61
Encoder system		Encoder (absolute)	Encoder (absolute)	Encoder (absolute)	Encoder (absolute)
Output signal		DRIVE-CLiQ	DRIVE-CLiQ	DRIVE-CLiQ	DRIVE-CLiQ
SIL certification		not certified	not certified	not certified	not certified
Options and their characteristics					
Version with SIL certification		ERT 100-40-N-N-D-2	ERT 100-40-B-N-D-2	ERT 100-54-N-N-D-2	ERT 100-54-B-N-D-2
ID		1529424	1529426	1529425	1529427
SIL certification		2	2	2	2

① The peak torques serve as short-term drive reserves when accelerating and delaying.

① Swivel and pause times apply for motions without restricted speeds at max. current. Reducing the max. current increases swivel periods and reduces rest periods. Higher mass moments of inertia are possible. Diagrams only apply for sufficiently rigid designs. Please contact us for assistance with the design of your application.

ERT 100

Universal rotary unit

Main view

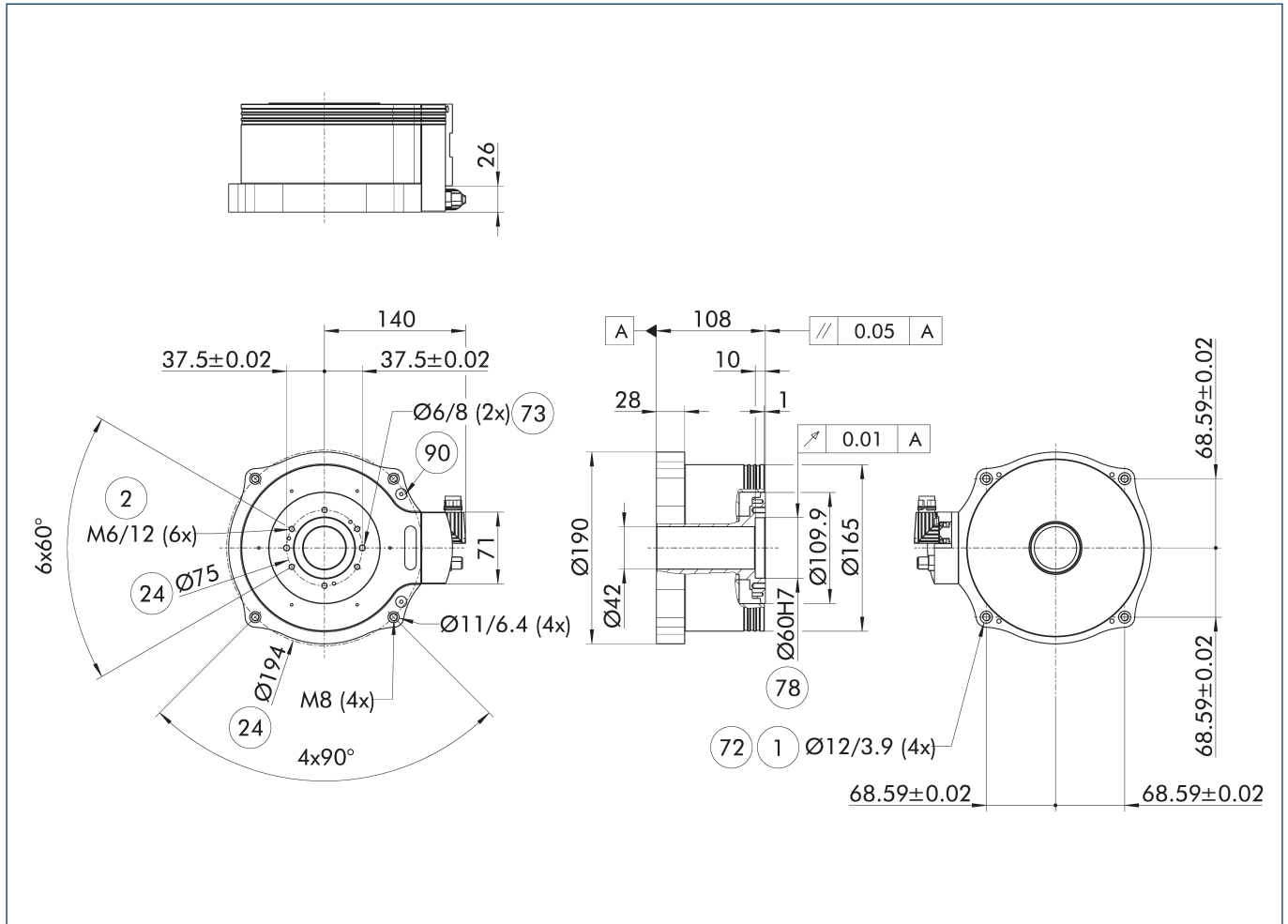

- ① Connection swivel unit
- ② Attachment connection
- ④ Bolt circle
- ⑦ Fit for centering sleeves
- ⑦③ Fit for centering pins
- ⑦⑧ Fit for centering
- ⑨⑩ Ground connection

View for protection class IP54

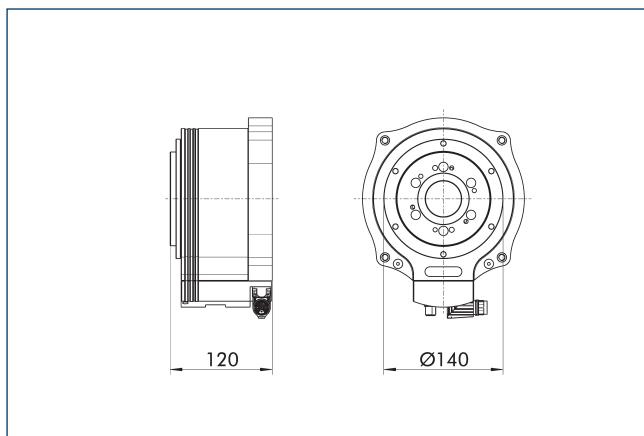

The view shows the height of the ERT with protection class IP54.

View for HIPERFACE DSL®

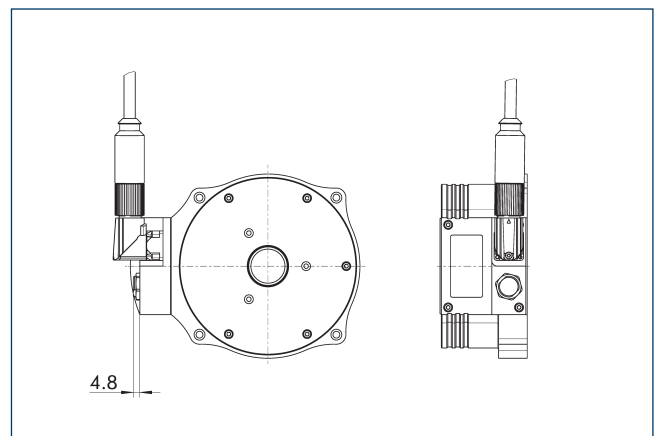

The view shows the ERT with the single-cable technology HIPERFACE DSL®.

Power cable

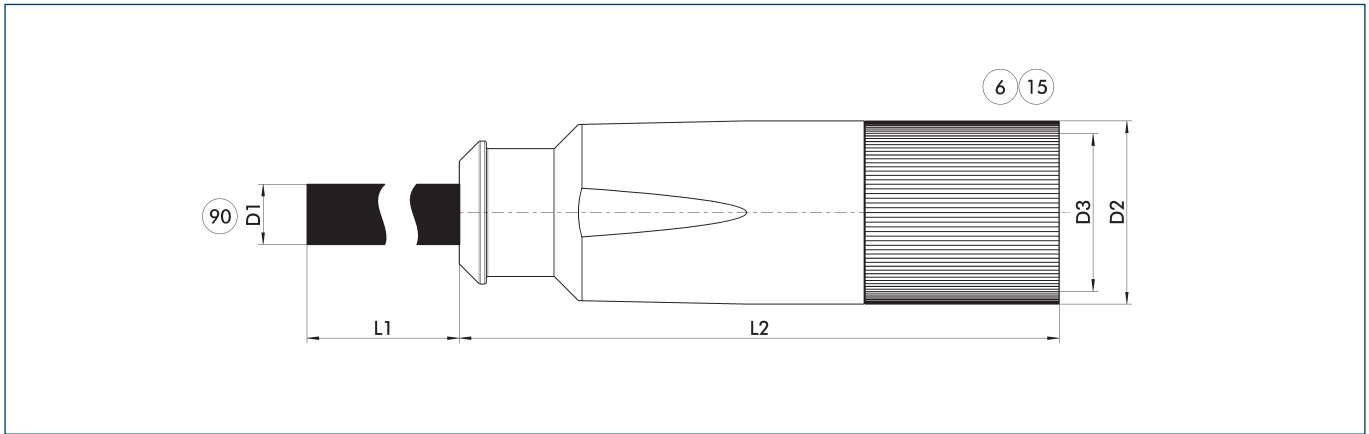

Connection cables such as power cables and encoder cables are specifically designed for connecting SCHUNK products with drive control units. We will gladly help you to select the right connection cables.

⑥ Connection module side
⑮ Socket

⑨⑩ Prefabricated to connect to the higher-level components

Description	ID	L1 [m]	D1 [mm]	L2 [mm]	D2 [mm]	D3
Power cable for BOSCH Rexroth IndraDrive Cs - cable track-compatible						
KA GLT1708-LK-00500-C	1420596	5	11	55	21.1	M17
KA GLT1708-LK-01000-C	1420607	10	11	55	21.1	M17
KA GLT1708-LK-01500-C	1436382	15	11	55	21.1	M17
KA GLT1708-LK-02000-C	1436389	20	11	55	21.1	M17
Power cable for Siemens SINAMICS with DRIVE-CLiQ - cable track compatible						
ERT - DQ 05m	1462959	5	11	55	21.1	M17
ERT - DQ 10m	1462964	10	11	55	21.1	M17
ERT - DQ 15m	1462967	15	11	55	21.1	M17
ERT - DQ 20m	1462969	20	11	55	21.1	M17

① Please observe the min. bending radius for cable track-compatible cables or the max. torsion angle for torsion-compatible cables. These are generally 10 times the cable diameter or +/- 180°/m.

ERT 100

Universal rotary unit

Encoder cable

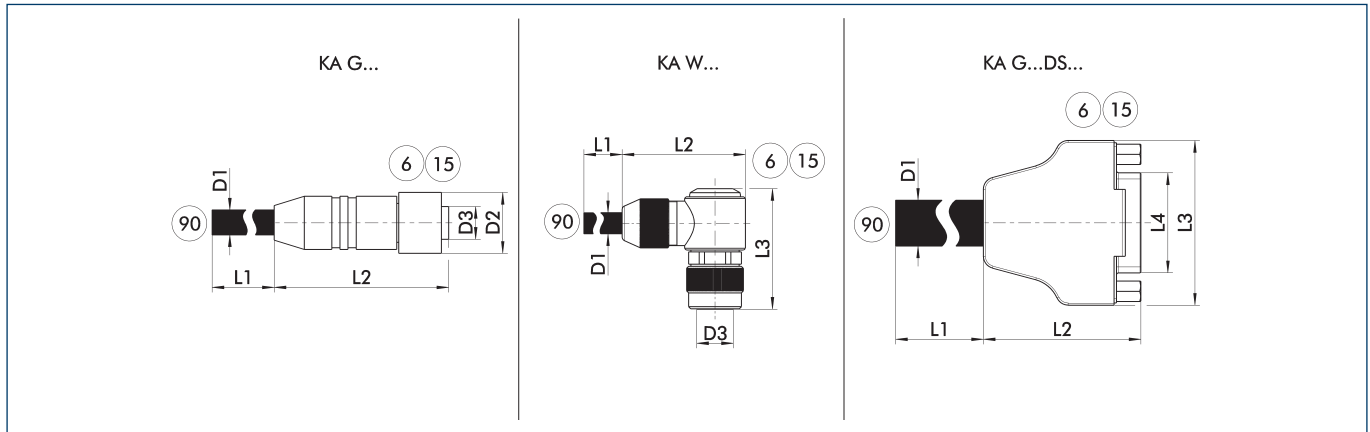

KA G... encoder cable with straight plug
 KA W... encoder cable with angled plug
 KA G...DS... Sub D encoder cable

⑥ Connection module side
 ⑮ Socket
 ⑨⑩ Prefabricated for connection to the drive controller

Connection cables such as power cables and encoder cables are specifically designed for connecting SCHUNK products with drive control units. We will gladly help you to select the right connection cables.

Description	ID	L1	D1	L2	D2	L3	D3
		[m]	[mm]	[mm]	[mm]	[mm]	
Encoder cable for BOSCH IndraDrive A/B/Cs and HIPERFACE® encoder interface – drag chain compatible							
KA WWN1208-GK-00500-K	0349544	5	6	37.5	14.9	30.8	M12
KA WWN1208-GK-01000-K	0349545	10	6	37.5	14.9	30.8	M12
KA WWN1208-GK-01500-K	0349546	15	6	37.5	14.9	30.8	M12
KA WWN1208-GK-02000-K	0349547	20	6	37.5	14.9	30.8	M12
Sensor cable for Siemens SINAMICS and encoder interface DRIVE-CLiQ – cable track compatible							
ERD/ERT - DQ 05m	1395066	5	6	37.5	14.9	30.8	M12
ERD/ERT - DQ 10m	1395071	10	6	37.5	14.9	30.8	M12
ERD/ERT - DQ 15m	1388995	15	6	37.5	14.9	30.8	M12
ERD/ERT - DQ 20m	1395076	20	6	37.5	14.9	30.8	M12

ⓘ Please observe the min. bending radius for cable track-compatible cables or the max. torsion angle for torsion-compatible cables. These are generally 10 times the cable diameter or +/- 180°/m.

Hybrid cable

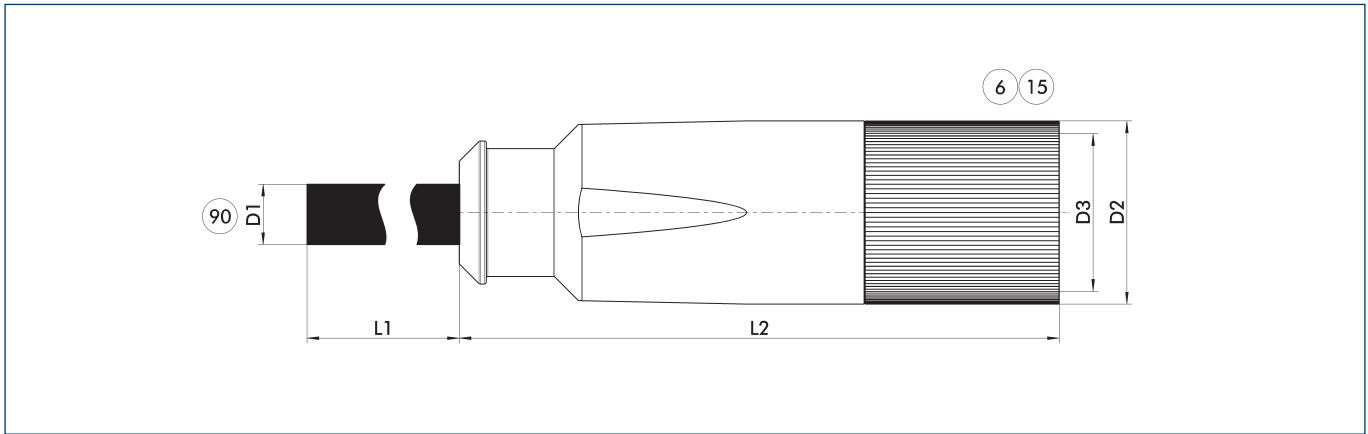

Connection cables such as power cables and encoder cables are specifically designed for connecting SCHUNK products with drive control units. We will gladly help you to select the right connection cables.

- ⑥ Connection module side
- ⑮ Socket

- ⑨⑩ Prefabricated to connect to the higher-level components

Description	ID	L1	D1	L2	D2	D3
		[m]	[mm]	[mm]	[mm]	
Hybrid cable						
ERT - HiperfaceDSL 05m	1528548	5	11	55	21.1	M17
ERT - HiperfaceDSL 10m	1528550	10	11	55	21.1	M17
ERT - HiperfaceDSL 15m	1528552	15	11	55	21.1	M17
ERT - HiperfaceDSL 20m	1528553	20	11	55	21.1	M17

① Please observe the min. bending radius for cables suitable for drag chain applications and the max. torsion angle for torsion-compatible cables. These are generally ten times the cable diameter or $\pm 180^\circ/m$. Please note additionally that the hybrid cables can only be used in conjunction with a drive controller that supports the Hiperface DSL® interface. This interface is currently only supported by the Beckhoff AX8000 drive controller. Please contact us if you would like to use our product with other controllers that support the Hiperface DSL® interface.

Bosch Rexroth IndraDrive Cs controller

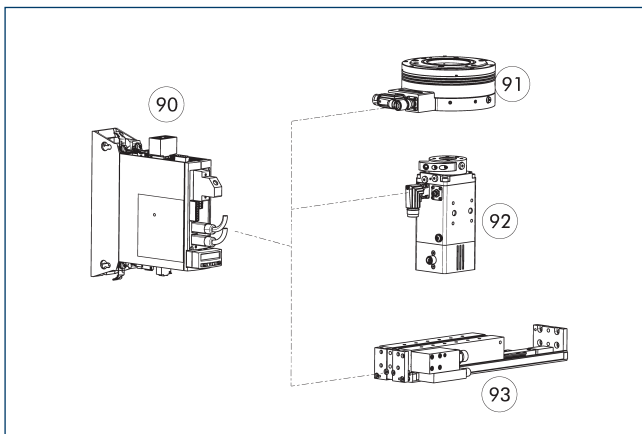

- ⑨⑩ Controller
- ⑨① Rotary module ERS/ERT, electric
- ⑨② ERD Rotary unit
- ⑨③ Compact linear module ELB

The controller can be used to operate the rotary modules ERS, ERT and ERD as well as for SCHUNK linear motor axes. It is available with the PROFIBUS or Multi-Ethernet (Sercos III, PROFINET, EtherCAT, EtherNet/IP) communication interfaces.

Description	Nominal current	Maximum current	Note
	[A]	[A]	
Controller			
HCS01.1E-W0008	2.7	8	

① We will be happy to help you select the right controller. Please contact us for assistance.

ERT 300

Universal rotary unit

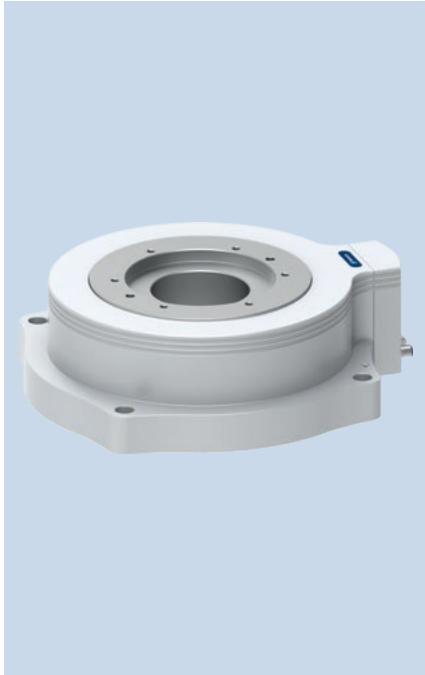

Swivel time diagram

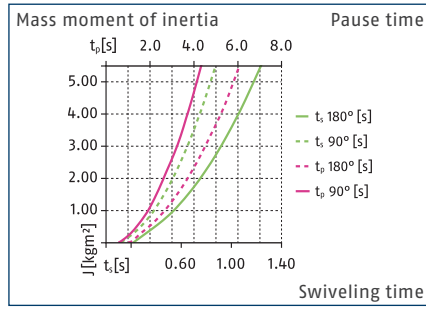

Swivel time diagram IP54

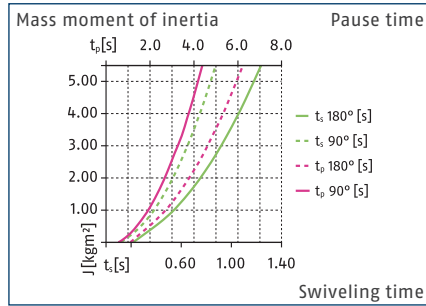

Dimensions and maximum loads

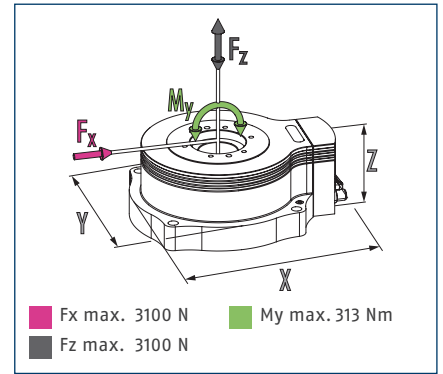

① The indicated forces and moments are maximum values for individual loading. If several forces and/or moments are applied at the same time, the maximum permitted individual values will be lower.

Technical data – HIPERFACE® interface

Description		ERT 300-40-N-N-H-N	ERT 300-40-B-N-H-N	ERT 300-54-N-N-H-N	ERT 300-54-B-N-H-N
ID		1436908	1436909	1461504	1461505
General operating data					
Rated/maximum torque	[Nm]	32/76	31/76	32/76	31/76
Max. rotational speed	[1/min]	150	150	150	150
Max. permissible mass moment of inertia	[kgm ²]	5.53	5.53	5.53	5.53
Repeat accuracy	[°]	0.01	0.01	0.01	0.01
Radial/axial runout	[mm]	0.05/0.05	0.05/0.05	0.05/0.05	0.05/0.05
Weight	[kg]	19.5	23.8	20.9	25.2
Min./max. ambient temperature	[°C]	5/40	5/40	5/40	5/40
IP protection class		40	40	54	54
Moment holding brake	[Nm]		31		31
Dimensions X x Y x Z	[mm]	372 x 330 x 110	372 x 330 x 110	372 x 330 x 124	372 x 330 x 124
Electrical operating data					
Intermediate circuit voltage	[V]	560	560	560	560
Rated/maximum current	[A]	4.4/14	4.2/14	4.4/14	4.2/14
Encoder system		Encoder (absolute)	Encoder (absolute)	Encoder (absolute)	Encoder (absolute)
Output signal		HIPERFACE®	HIPERFACE®	HIPERFACE®	HIPERFACE®
SIL certification		not certified	not certified	not certified	not certified

① The peak torques serve as short-term drive reserves when accelerating and delaying.

② Swivel and pause times apply for motions without restricted speeds at max. current. Reducing the max. current increases swivel periods and reduces rest periods. Higher mass moments of inertia are possible. Diagrams only apply for sufficiently rigid designs. Please contact us for assistance with the design of your application.

Technical data – HIPERFACE-DSL® interface

Description		ERT 300-40-N-N-L-N	ERT 300-40-B-N-L-N	ERT 300-54-N-N-L-N	ERT 300-54-B-N-L-N
ID		1529450	1529452	1529451	1529453
General operating data					
Rated/maximum torque	[Nm]	32/76	31/76	32/76	31/76
Max. rotational speed	[1/min]	150	150	150	150
Max. permissible mass moment of inertia	[kgm ²]	5.53	5.53	5.53	5.53
Repeat accuracy	[°]	0.01	0.01	0.01	0.01
Radial/axial runout	[mm]	0.05/0.05	0.05/0.05	0.05/0.05	0.05/0.05
Weight	[kg]	19.5	23.8	20.9	25.2
Min./max. ambient temperature	[°C]	5/40	5/40	5/40	5/40
IP protection class		40	40	54	54
Moment holding brake	[Nm]		31		31
Dimensions X x Y x Z	[mm]	372 x 330 x 110	372 x 330 x 110	372 x 330 x 124	372 x 330 x 124
Electrical operating data					
Intermediate circuit voltage	[V]	560	560	560	560
Rated/maximum current	[A]	4.4/14	4.2/14	4.4/14	4.2/14
Encoder system		Encoder (absolute)	Encoder (absolute)	Encoder (absolute)	Encoder (absolute)
Output signal		HIPERFACE DSL®	HIPERFACE DSL®	HIPERFACE DSL®	HIPERFACE DSL®
SIL certification		not certified	not certified	not certified	not certified

① The peak torques serve as short-term drive reserves when accelerating and delaying.

① Swivel and pause times apply for motions without restricted speeds at max. current. Reducing the max. current increases swivel periods and reduces rest periods. Higher mass moments of inertia are possible. Diagrams only apply for sufficiently rigid designs. Please contact us for assistance with the design of your application.

Technical data – DRIVE-CLiQ interface

Description		ERT 300-40-N-N-D-N	ERT 300-40-B-N-D-N	ERT 300-54-N-N-D-N	ERT 300-54-B-N-D-N
ID		1461502	1461503	1461506	1461507
General operating data					
Rated/maximum torque	[Nm]	32/76	31/76	32/76	31/76
Max. rotational speed	[1/min]	150	150	150	150
Max. permissible mass moment of inertia	[kgm ²]	5.53	5.53	5.53	5.53
Repeat accuracy	[°]	0.01	0.01	0.01	0.01
Radial/axial runout	[mm]	0.05/0.05	0.05/0.05	0.05/0.05	0.05/0.05
Weight	[kg]	19.5	23.8	20.9	25.2
Min./max. ambient temperature	[°C]	5/40	5/40	5/40	5/40
IP protection class		40	40	54	54
Moment holding brake	[Nm]		31		31
Dimensions X x Y x Z	[mm]	372 x 330 x 110	372 x 330 x 110	372 x 330 x 124	372 x 330 x 124
Electrical operating data					
Intermediate circuit voltage	[V]	560	560	560	560
Rated/maximum current	[A]	4.4/14	4.2/14	4.4/14	4.2/14
Encoder system		Encoder (absolute)	Encoder (absolute)	Encoder (absolute)	Encoder (absolute)
Output signal		DRIVE-CLiQ	DRIVE-CLiQ	DRIVE-CLiQ	DRIVE-CLiQ
SIL certification		not certified	not certified	not certified	not certified
Options and their characteristics					
Version with SIL certification		ERT 300-40-N-N-D-2	ERT 300-40-B-N-D-2	ERT 300-54-N-N-D-2	ERT 300-54-B-N-D-2
ID		1482057	1482059	1482073	1482074
SIL certification		2	2	2	2

① The peak torques serve as short-term drive reserves when accelerating and delaying.

① Swivel and pause times apply for motions without restricted speeds at max. current. Reducing the max. current increases swivel periods and reduces rest periods. Higher mass moments of inertia are possible. Diagrams only apply for sufficiently rigid designs. Please contact us for assistance with the design of your application.

ERT 300

Universal rotary unit

Main view

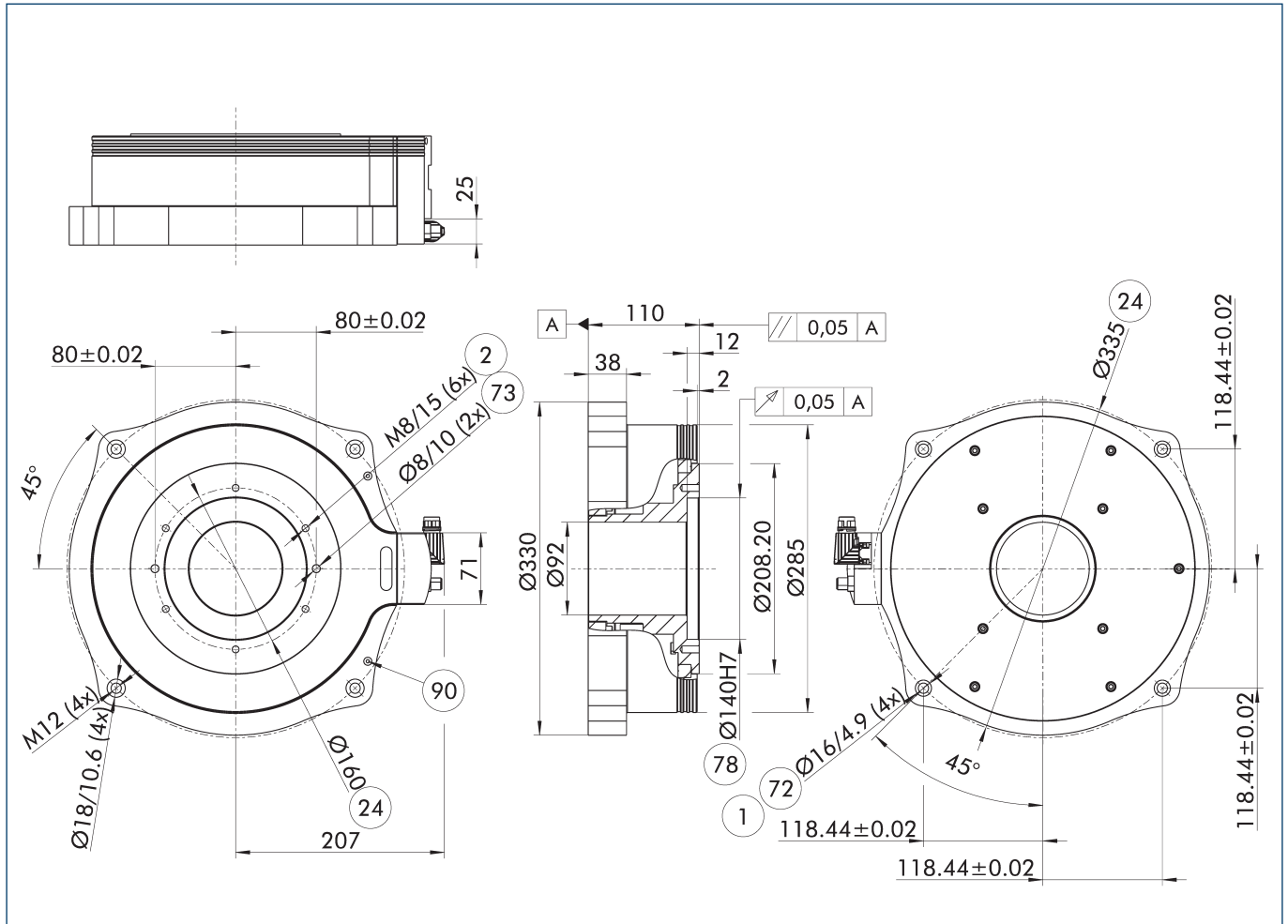

- ① Connection swivel unit
- ② Attachment connection
- ④ Bolt circle
- ⑦ Fit for centering sleeves
- ⑦③ Fit for centering pins
- ⑦⑧ Fit for centering
- ⑨⑩ Ground connection

View for protection class IP54

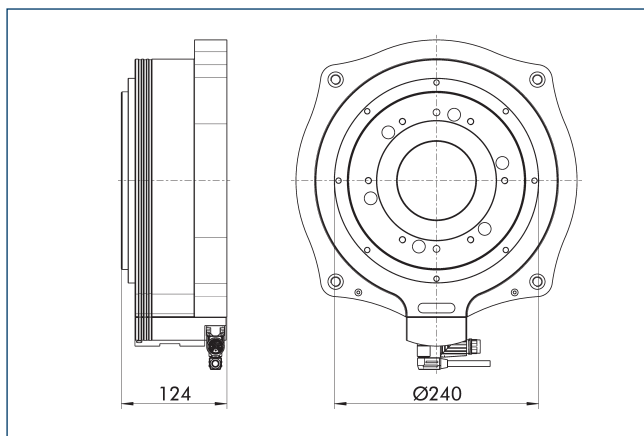

The view shows the height of the ERT with protection class IP54.

View for HIPERFACE DSL®

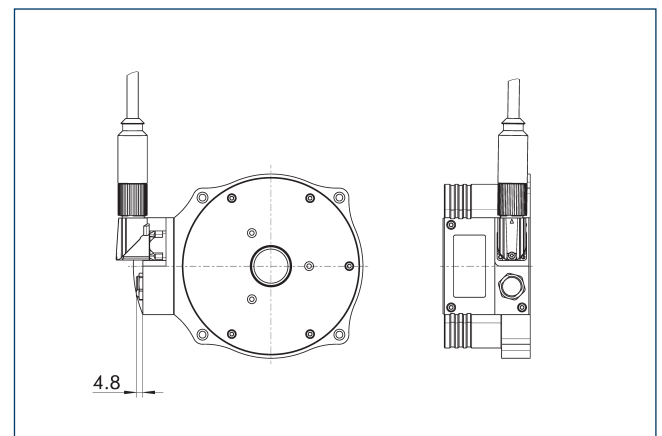

The view shows the ERT with the single-cable technology HIPERFACE DSL®.

Power cable

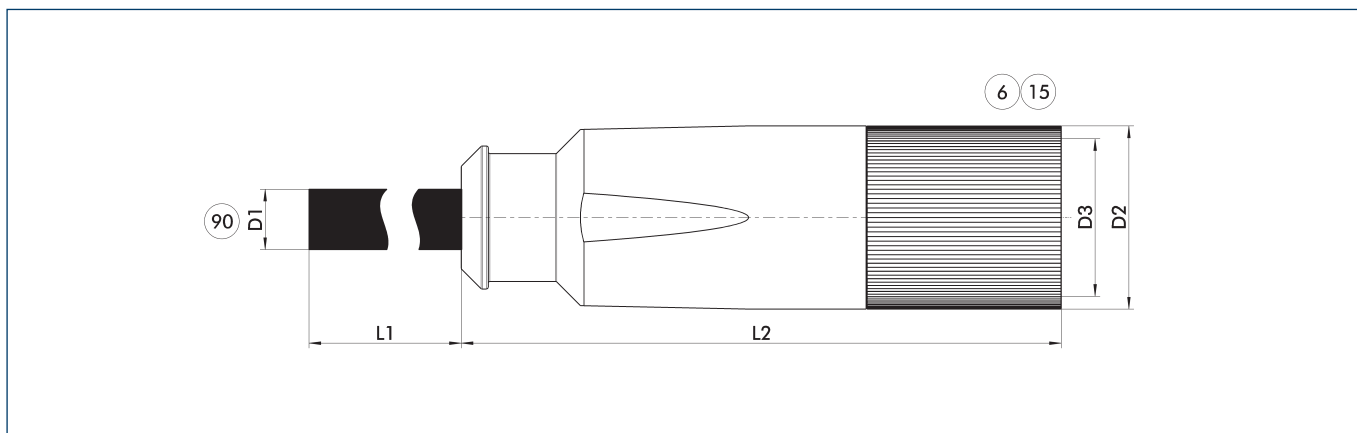

Connection cables such as power cables and encoder cables are specifically designed for connecting SCHUNK products with drive control units. We will gladly help you to select the right connection cables.

⑥ Connection module side
⑮ Socket

⑨⑩ Prefabricated to connect to the higher-level components

Description	ID	L1 [m]	D1 [mm]	L2 [mm]	D2 [mm]	D3
Power cable for BOSCH Rexroth IndraDrive Cs - cable track-compatible						
KA GLT1708-LK-00500-C	1420596	5	11	55	21.1	M17
KA GLT1708-LK-01000-C	1420607	10	11	55	21.1	M17
KA GLT1708-LK-01500-C	1436382	15	11	55	21.1	M17
KA GLT1708-LK-02000-C	1436389	20	11	55	21.1	M17
Power cable for Siemens SINAMICS with DRIVE-CLiQ - cable track compatible						
ERT - DQ 05m	1462959	5	11	55	21.1	M17
ERT - DQ 10m	1462964	10	11	55	21.1	M17
ERT - DQ 15m	1462967	15	11	55	21.1	M17
ERT - DQ 20m	1462969	20	11	55	21.1	M17

① Please observe the min. bending radius for cable track-compatible cables or the max. torsion angle for torsion-compatible cables. These are generally 10 times the cable diameter or +/- 180°/m.

ERT 300

Universal rotary unit

Encoder cable

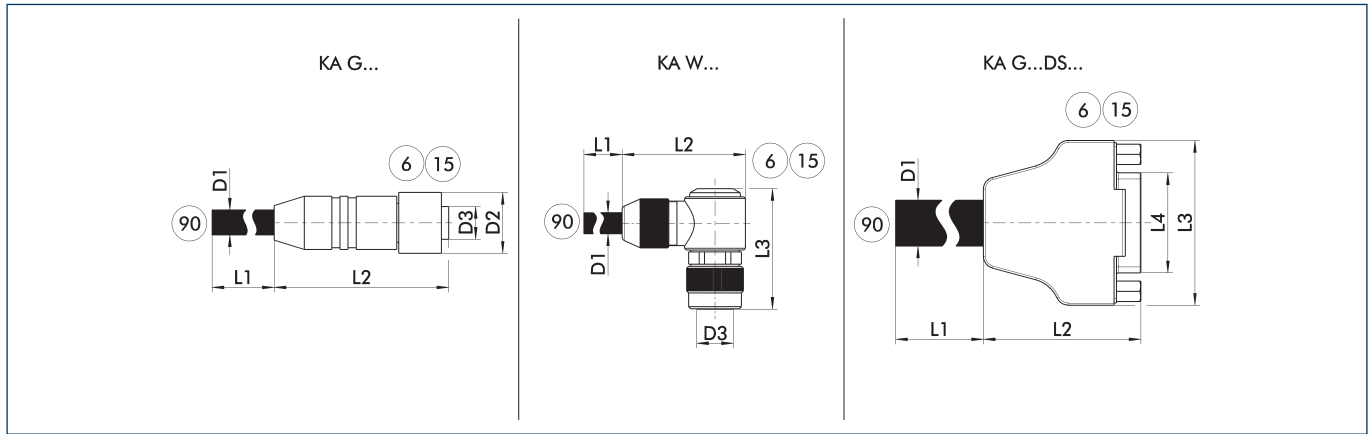

KA G... encoder cable with straight plug
 KA W... encoder cable with angled plug
 KA G...DS... Sub D encoder cable

⑥ Connection module side
 ⑮ Socket
 ⑨⑩ Prefabricated for connection to the drive controller

Connection cables such as power cables and encoder cables are specifically designed for connecting SCHUNK products with drive control units. We will gladly help you to select the right connection cables.

Description	ID	L1	D1	L2	D2	L3	D3
		[m]	[mm]	[mm]	[mm]	[mm]	
Encoder cable for BOSCH IndraDrive A/B/Cs and HIPERFACE® encoder interface – drag chain compatible							
KA WWN1208-GK-00500-K	0349544	5	6	37.5	14.9	30.8	M12
KA WWN1208-GK-01000-K	0349545	10	6	37.5	14.9	30.8	M12
KA WWN1208-GK-01500-K	0349546	15	6	37.5	14.9	30.8	M12
KA WWN1208-GK-02000-K	0349547	20	6	37.5	14.9	30.8	M12
Sensor cable for Siemens SINAMICS and encoder interface DRIVE-CLiQ – cable track compatible							
ERD/ERT - DQ 05m	1395066	5	6	37.5	14.9	30.8	M12
ERD/ERT - DQ 10m	1395071	10	6	37.5	14.9	30.8	M12
ERD/ERT - DQ 15m	1388995	15	6	37.5	14.9	30.8	M12
ERD/ERT - DQ 20m	1395076	20	6	37.5	14.9	30.8	M12

ⓘ Please observe the min. bending radius for cable track-compatible cables or the max. torsion angle for torsion-compatible cables. These are generally 10 times the cable diameter or +/- 180°/m.

Hybrid cable

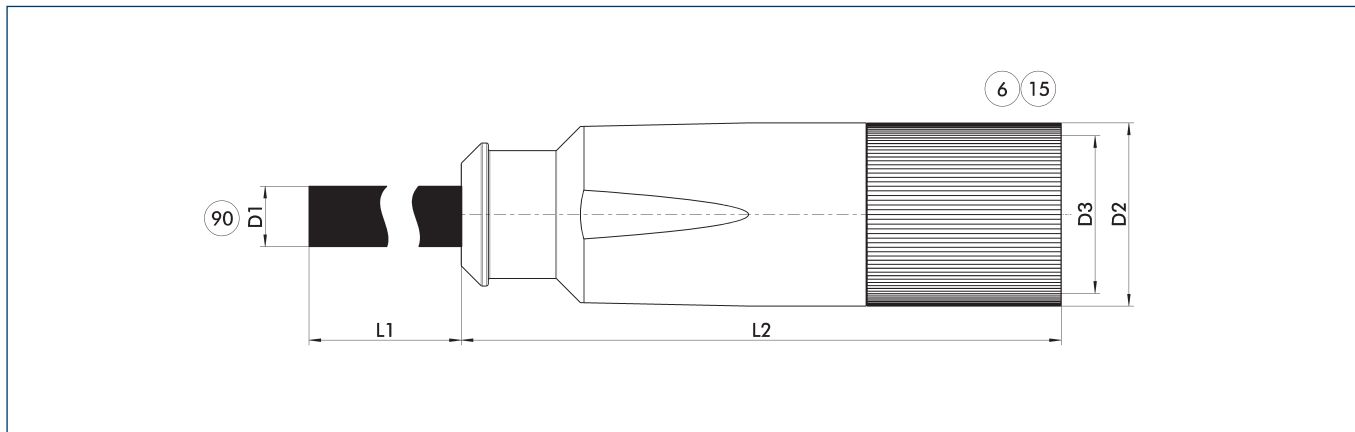

Connection cables such as power cables and encoder cables are specifically designed for connecting SCHUNK products with drive control units. We will gladly help you to select the right connection cables.

- ⑥ Connection module side
- ⑮ Socket

- ⑨⑩ Prefabricated to connect to the higher-level components

Description	ID	L1	D1	L2	D2	D3
		[m]	[mm]	[mm]	[mm]	
Hybrid cable						
ERT - HiperfaceDSL 05m	1528548	5	11	55	21.1	M17
ERT - HiperfaceDSL 10m	1528550	10	11	55	21.1	M17
ERT - HiperfaceDSL 15m	1528552	15	11	55	21.1	M17
ERT - HiperfaceDSL 20m	1528553	20	11	55	21.1	M17

ⓘ Please observe the min. bending radius for cables suitable for drag chain applications and the max. torsion angle for torsion-compatible cables. These are generally ten times the cable diameter or $\pm 180^\circ/m$. Please note additionally that the hybrid cables can only be used in conjunction with a drive controller that supports the Hiperface DSL® interface. This interface is currently only supported by the Beckhoff AX8000 drive controller. Please contact us if you would like to use our product with other controllers that support the Hiperface DSL® interface.

Bosch Rexroth IndraDrive Cs controller

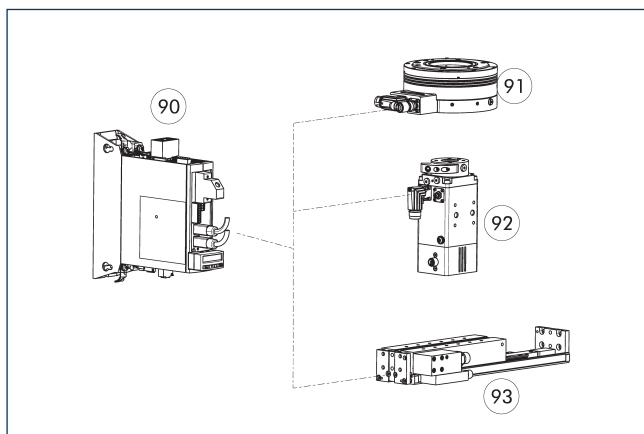

- ⑨⑩ Controller
- ⑨① Rotary module ERS/ERT, electric
- ⑨② ERD Rotary unit
- ⑨③ Compact linear module ELB

The controller can be used to operate the rotary modules ERS, ERT and ERD as well as for SCHUNK linear motor axes. It is available with the PROFIBUS or Multi-Ethernet (Sercos III, PROFINET, EtherCAT, EtherNet/IP) communication interfaces.

Description	Nominal current	Maximum current	Note
	[A]	[A]	
Controller			
HCS01.1E-W0018	7.6	18	

ⓘ We will be happy to help you select the right controller. Please contact us for assistance.



SCHUNK GmbH & Co. KG
Spann- und Greiftechnik

Bahnhofstr. 106 - 134
D-74348 Lauffen/Neckar
Tel. +49-7133-103-0
Fax +49-7133-103-2399
info@de.schunk.com
schunk.com

Folgen Sie uns | *Follow us*

