



Hand in hand for tomorrow



Product data sheet

Gripper for small components EGP 64

EGP

Gripper for small components

High Performance Density. Fast. Compact. Gripper for small components EGP

Electric 2-finger parallel gripper with smooth-running base jaws guided on roller bearings

Field of application

Gripping and moving of small to medium-sized workpieces with flexible force and high speed in clean environments, such as assembly, testing, laboratory and pharmaceutical industry

Advantages – Your benefits

Highest performance density for the use of smaller grippers sizes

Control via digital I/O for easy commissioning and rapid integration into existing systems.

Two to four stage adjustable gripping force for simple adaption to sensitive workpieces

Backlash-free, pre-loaded cross roller guide for precise gripping with nearly constant force for all permissible finger lengths

Very high maximum cycles per minute for highest productivity

Compact dimensions for minimal interfering contours in the application

Proven a thousand times MPG-plus basis for equal gripping forces and strokes with identically high efficiency

Brushless DC servomotor for almost wear-free use and a long service life

Control via IO-Link Enables pre-positioning of the gripper finger and evaluation of the gripper condition as well as the adjustability of special gripping modes.

NEW: food-grade lubrication as a solution for an easy entry into medical technology, lab automation, pharmaceutical and food industry



Sizes
Quantity: 4

m

Weight
0.11 .. 0.83 kg



Gripping force
12 .. 300 N



Stroke per jaw
3 .. 10 mm



Workpiece weight
0.07 .. 1.25 kg

Functional description

The brushless servomotor drives the base jaw via the gear mechanism.

The jaw stroke is synchronized by means of rack and pinion kinematics.

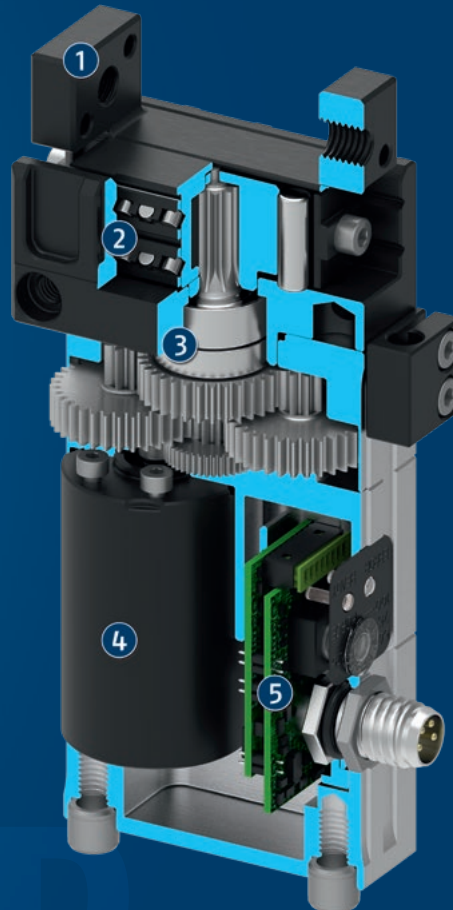

- ① **Base jaw**
for the connection of workpiece-specific gripper fingers
- ② **Cross roller guidance**
precise gripping due to backlash-free base jaw guidance
- ③ **Gear**
Rack and pinion principle for centric gripping
- ④ **Drive**
Brushless DC servomotor
- ⑤ **Control electronics**
Integrated control and power electronics for decentralized control of the servomotor

General notes about the series

Operating principle: Rack and pinion principle

Housing material: Aluminum alloy, coated

Base jaw material: Steel

Actuation: servo-electric, via brushless DC servomotor

Warranty: 24 months

Service life characteristics: on request

Scope of delivery: Gripper including safety information and accessory kit with centering sleeves for gripper and finger mounting. Product-specific instructions and software can be downloaded at schunk.com/downloads-manuals and schunk.com/downloads-software.

Gripping force: is the arithmetic sum of the individual force applied to each jaw at distance P (see illustration).

Finger length: is measured from the reference surface as the distance P in direction to the main axis.

Repeat accuracy (gripping): defined as the spread of the actual position at 100 consecutive closing or opening movements on a rigid workpiece or a fixed workpiece stop under constant conditions.

Repeat accuracy (positioning, unidirectional): defined as the spread of the actual position of the base jaws after 100 consecutive movements to a target position from the same direction under constant conditions.

Repeat accuracy (positioning, bi-directional): defined as the spread of the actual position of the base jaws after 100 consecutive movements to a target position from both directions under constant conditions.

Workpiece weight: is calculated for force-fit gripping with a coefficient of static friction of 0.1 and a safety factor of 2 against workpiece slippage at acceleration due to gravity g. For form-fit or capture gripping, there are significantly higher permissible workpiece weights.

Closing and opening times: are movement times of the base jaws only, without application-specific gripper fingers. PLC reaction times are not included in the above-mentioned times and must be taken into consideration when determining cycle times.

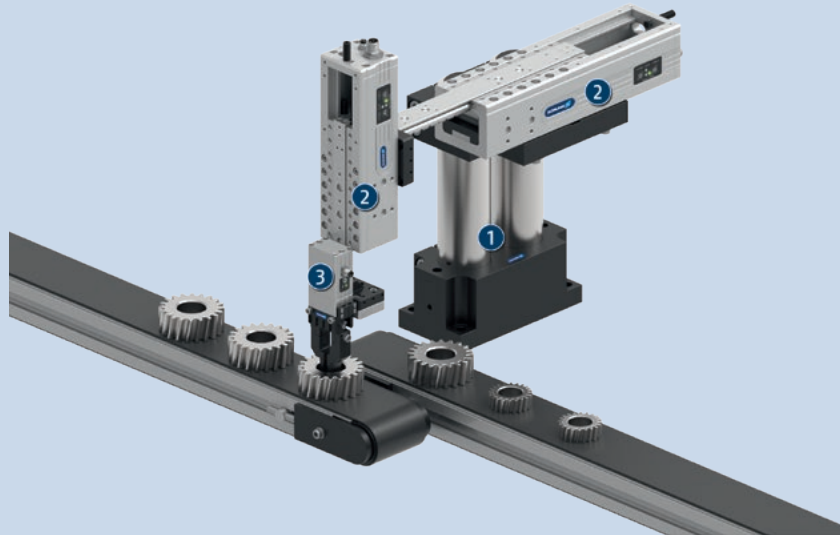

Application example

Pick & place unit driven by linear motor for dynamic movements.

- ① Pillar assembly system
- ② Electric linear module ELP

- ③ Electric 2-finger parallel gripper EGP

SCHUNK offers more ...

The following components make the product even more productive – the suitable addition for the highest functionality, flexibility, reliability, and controlled production.



Linear module



Rotation unit



Rotary gripper module



Pick & Place Unit



Connection cables



Inductive proximity switch

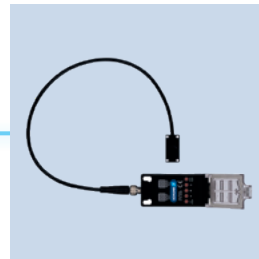

Flexible position sensor



Finger blank

① For more information on these products can be found on the following product pages or at [schunk.com](https://www.schunk.com).

Options and special information

Manually adjustable gripping force: With an integrated rotary switch, the gripping force can be adjusted in two stages for the EGP 25 to 100% and 50%, and in four stages for EGP 40, 50 and 64 to 100%, 75%, 50%, and 25%.

Version with IO-Link: The integration of IO-Link makes it possible to adjust the gripping force, to pre-position the gripper fingers and to evaluate the gripper status.

New! Gripping modes with IO-Link: In addition to a cycle time-optimized gripping mode (FastGrip), the IO-Link version also offers a gripping mode with pulse reduction of the gripping force (SoftGrip) for gripping fragile workpieces.

Speed version S: for faster closing and opening times due to the use of a different gear ratio. The option of a gripping force adjustment is no longer available.

Optional status monitoring via external sensor system: The status of the gripper can be monitored by external sensors.

Optional adapter plates: Space saving, front-end fastening of the gripper is enabled by optional adapter plates.

KA connection cable: Connection cables with an angled or a straight female connector can be ordered in various lengths to connect the gripper with the power supply and higher-level control system.

Food-grade lubrication: The product contains food-compliant lubricants as standard. The requirements of standard EN 1672-2:2020 are not fully met. The relevant NSF certificates are available at <https://info.nsf.org/USDA/Listings.asp> using the lubricant information in the operating manual. Components such as rolling bearings, linear guides, or shock absorbers are not provided with food-compliant lubricants.

EGP 64

Gripper for small components



Gripping force

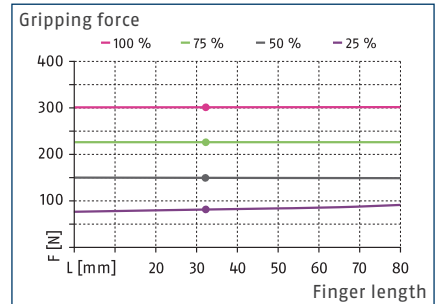

Gripping modes with IO-Link

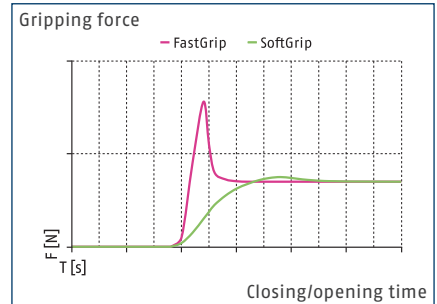

Dimensions and maximum loads

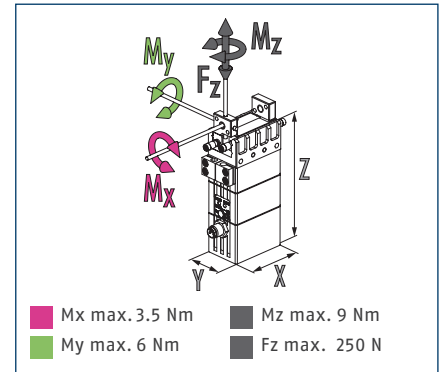

① The indicated moments and forces are static values, apply for each base jaw and may appear simultaneously. Loads may additionally occur to the moment produced by the gripping force itself.

Technical data

Description		EGP 64-N-N-B
ID		0310980
General operating data		
Stroke per jaw	[mm]	10
Min./max. gripping force	[N]	75/300
Recommended workpiece weight	[kg]	1.25
Max. permissible finger length	[mm]	80
Max. permissible weight per finger	[kg]	0.24
Repeat accuracy (gripping)	[mm]	0.02
Closing/opening time	[s]	0.49/0.49
Weight	[kg]	0.8
Min./max. ambient temperature	[°C]	5/55
IP protection class		30
Cleanroom class ISO 14644-1:1999		5
Noise emission	[dB(A)]	<70
Dimensions X x Y x Z	[mm]	64 x 35 x 114.7
Electrical operating data		
Nominal voltage	[V]	24
Nominal current	[A]	0.15
Max. current	[A]	2
Controller electronics		integrated
Communication interface		Digital inputs
Number of digital I/O		2/-
Options and their characteristics		
Version with IO-Link		1383545
Weight	[kg]	0.83
Specification		V1.1
Transmission rate		COM2
Port		Class B
Repeat accuracy (positioning, unidirectional)	[mm]	±0.2
Repeat accuracy (positioning, bi-directional)	[mm]	±0.2
Gripping modes		FastGrip, SoftGrip

Main view

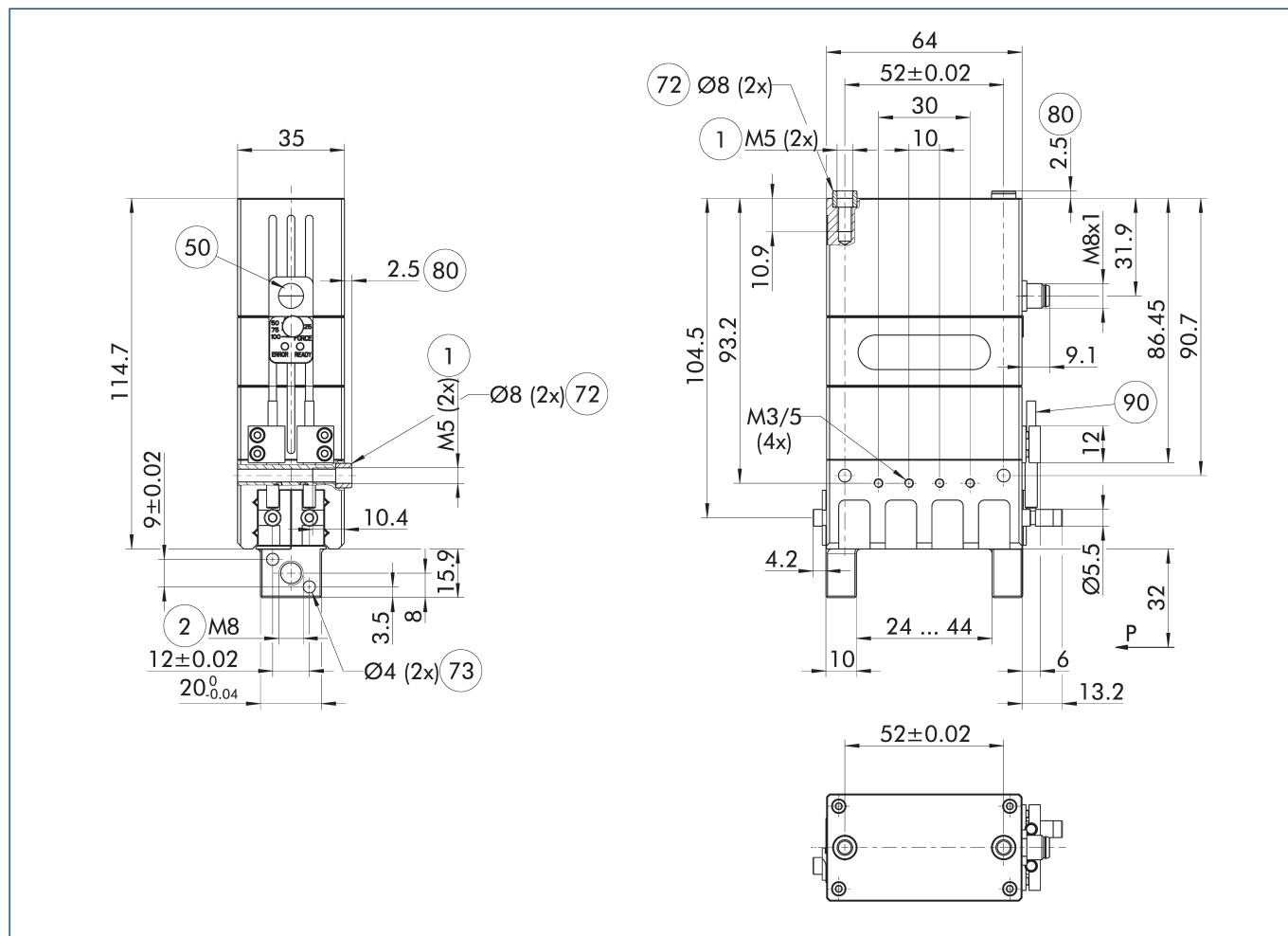

The drawing shows the basic version of the gripper with open jaws, without dimensional consideration of the options described below.

- ① Gripper connection
- ② Finger connection
- ⑤ Electrical connection
- ⑧ Depth of the centering sleeve hole in the counter part

Maximum permitted finger projection

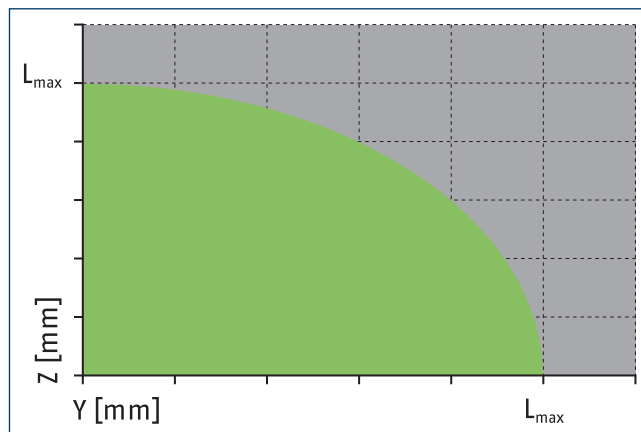
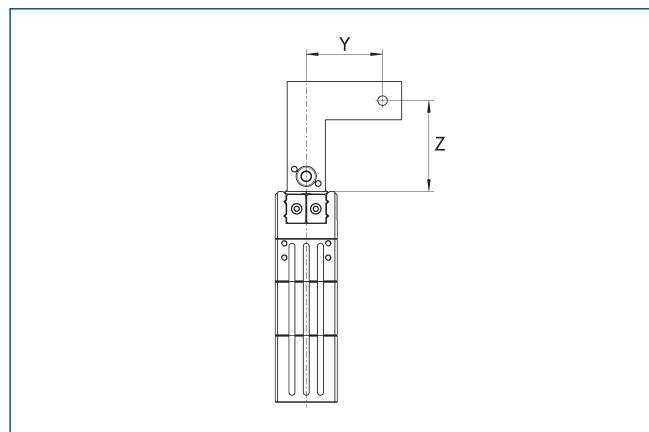

■ Permitted range ■ Inadmissible range
 L_{max} is equivalent to the maximum permitted finger length, see the technical data table.

EGP 64

Gripper for small components

Jaw design

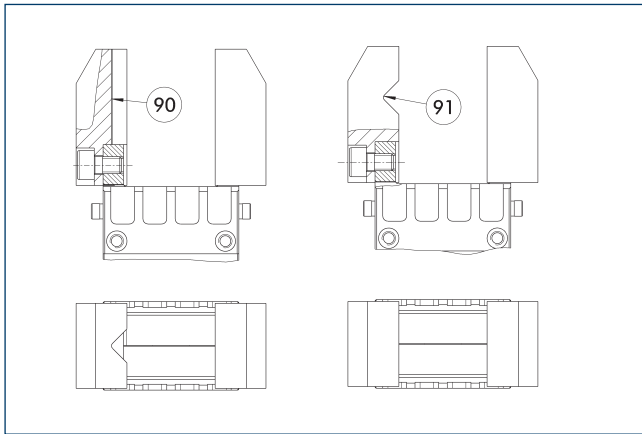

- 90 Vertically positioned prism
- 91 Horizontally positioned prism

A workpiece, which is gripped using three points of contact, can be reliably gripped with high repeatability. A system with more than three points of contact is overdetermined. The drawing shows two alternative gripper finger designs for coaxial and radial gripping of a cylindrical part.

I0-Link version I0L

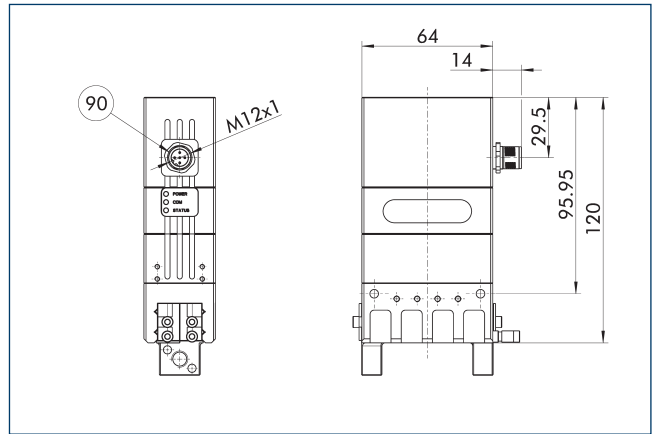

- 90 M12, 5-pin

The position of the gripper fingers and the gripping force can be set flexibly on the I0-link version. The drawing shows dimensional changes of the I0-Link version compared to the basic version found in the main view.

Adapter plate

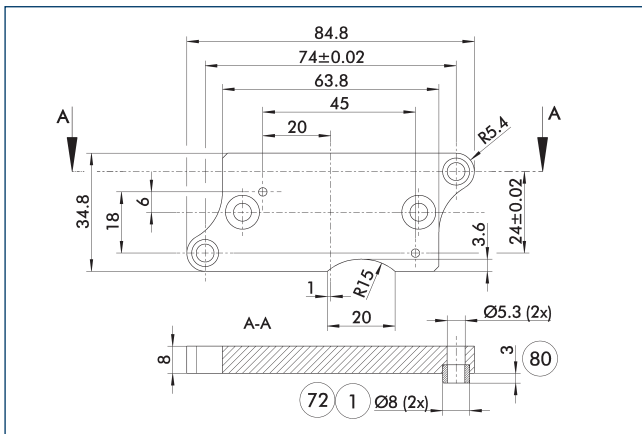

- 1 Gripper connection
- 72 Fit for centering sleeves
- 80 Depth of the centering sleeve hole in the counter part

The adapter plate includes an O-ring* for a direct air connection, additional centering sleeves, and screws for mounting the gripper. *Optional only with pneumatic actuators

Description	ID	
Adapter plate		
APL-MPG-plus 64	0305547	

① The adapter plate is a separately ordered, optional accessory.

Adapter plate

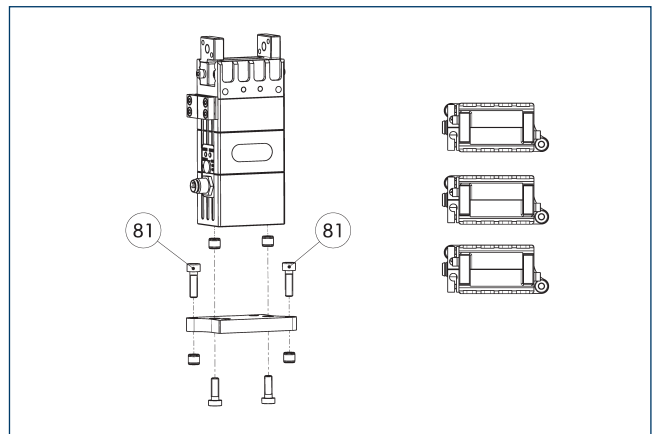

- 81 Not included in the scope of delivery

The adapter plate includes an O-ring* for a direct air connection, additional centering sleeves, and screws for mounting the gripper. *Optional only with pneumatic actuators

Description	ID	
Adapter plate		
APL-MPG-plus 64	0305547	

① The adapter plate is a separately ordered, optional accessory.

Finger blanks with BSWS ABR-BSWS-MPG-plus 64

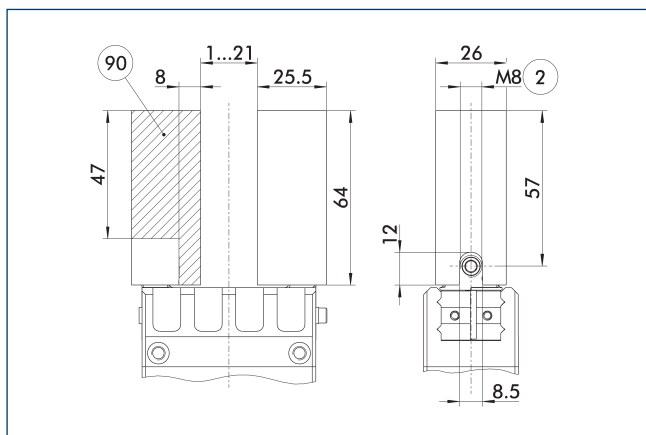

- ② Finger connection
- ⑨⑩ Machining volume

Finger blanks for customized subsequent machining with integrated jaw quick-change system for precise and fast finger changes.

Description	ID	Scope of delivery
Finger blank with jaw quick-change system		
ABR-BSWS-MPG-plus 64	0302898	2

Finger blanks with BSWS

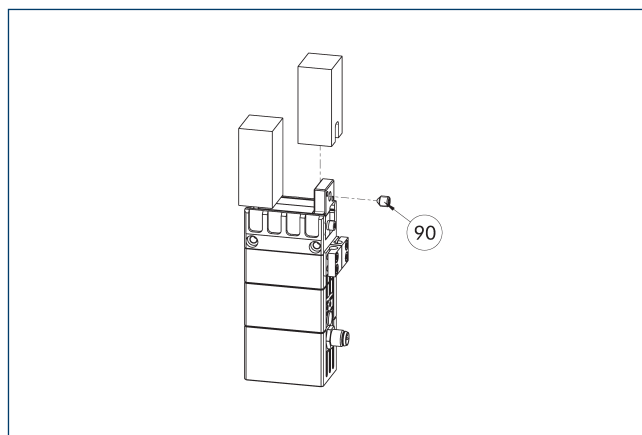

- ⑨⑩ Included in the scope of delivery

The finger blanks with jaw quick-change system allow fast and manual gripper finger changes. The mechanical interface to the gripper is already integrated. Only the specific workpiece geometry needs to be machined into the finger blank.

Description	ID	Scope of delivery
Finger blank with jaw quick-change system		
ABR-BSWS-MPG-plus 64	0302898	2

Finger blanks ABR-MPG-plus 64

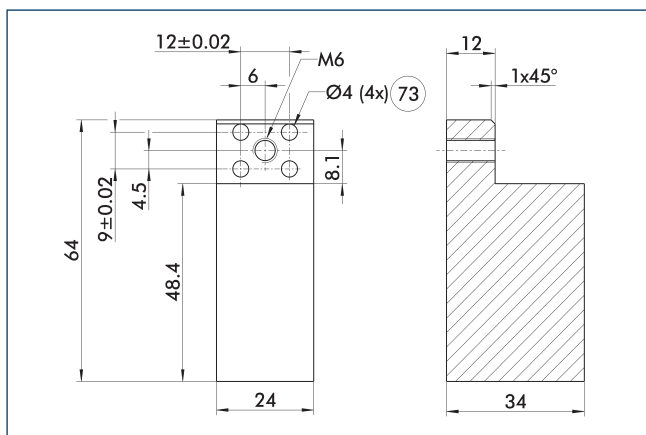

- ⑦③ Fit for centering pins

The drawing shows the finger blank which can be reworked by the customer.

Description	ID	Material	Scope of delivery
Finger blank			
ABR-MPG-plus 64	0340215	Aluminum (3.4365)	2

Modular Assembly Automation

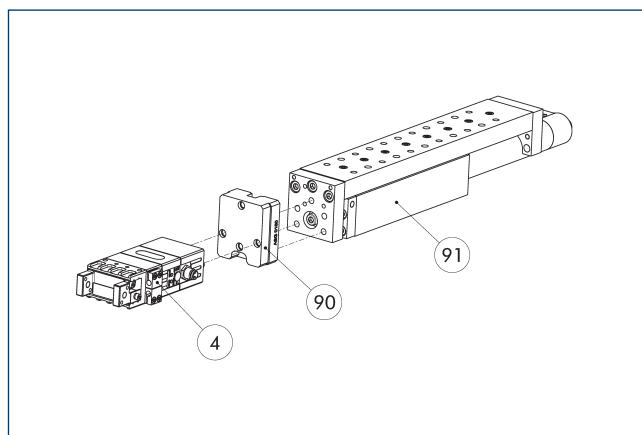

- ④ Grippers
- ⑨⑩ ASG adapter plate
- ⑨① Linear module CLM/KLM/LM/ELP/ELM/ELS/HLM

Grippers and linear modules can be combined with standard adapter plates from the modular assembly system. For more information see our main catalog "Modular Assembly Automation".

EGP 64

Gripper for small components

IN 40 inductive proximity switches

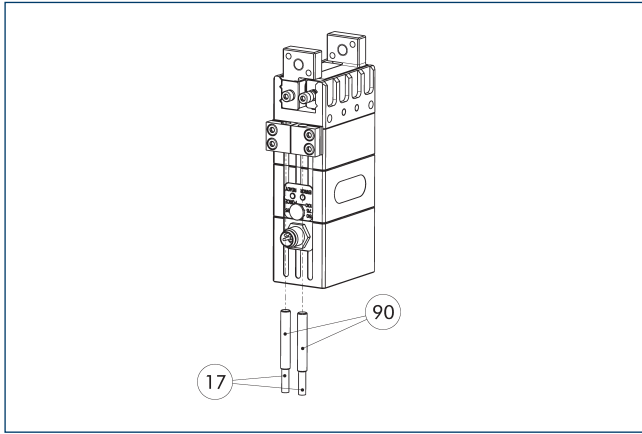

17 Cable outlet

90 Inductive proximity switches

Directly mounted end position monitoring.

Description	ID	Often combined
Inductive proximity switch		
IN 40-S-M12	0301574	
IN 40-S-M8	0301474	●
INK 40-S	0301555	
Connection cables		
KA BG08-L 3P-0300-PNP	0301622	●
KA BG08-L 3P-0500-PNP	0301623	
KA BG12-L 3P-0500-PNP	30016369	
KA BW08-L 3P-0300-PNP	0301594	
KA BW08-L 3P-0500-PNP	0301502	
KA BW12-L 3P-0300-PNP	0301503	
KA BW12-L 3P-0500-PNP	0301507	
Clip for connector/socket		
CLI-M12	0301464	
CLI-M8	0301463	
Cable extension		
KV BG12-SG12 3P-0030-PNP	0301999	
KV BG12-SG12 3P-0060-PNP	0301998	
KV BW08-SG08 3P-0030-PNP	0301495	
KV BW08-SG08 3P-0100-PNP	0301496	
KV BW08-SG08 3P-0200-PNP	0301497	●
KV BW12-SG12 3P-0030-PNP	0301595	
KV BW12-SG12 3P-0100-PNP	0301596	
KV BW12-SG12 3P-0200-PNP	0301597	
Sensor distributor		
V2-M12	0301776	●
V2-M8	0301775	●
V4-M8	0301746	
V8-M8	0301751	

① Two sensors are required per unit for monitoring two positions. On option, extension cables and sensor distributors are available. Additional product variants of the sensor, and further information and technical data can be found in the catalog chapter sensor system.

Attachment kit for FPS

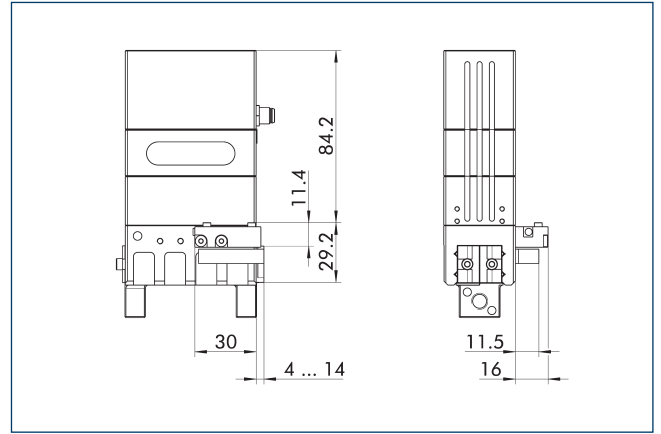

The following FPS position sensor can differentiate between five programmable areas or switching points for the stroke of a gripper, and can be used in connection with a PC as a measuring system.

Description	ID	
Attachment kit for FPS		
AS-FPS-MPG 64	0301764	

① This attachment kit needs to be ordered optionally as an accessory.

Flexible position sensor

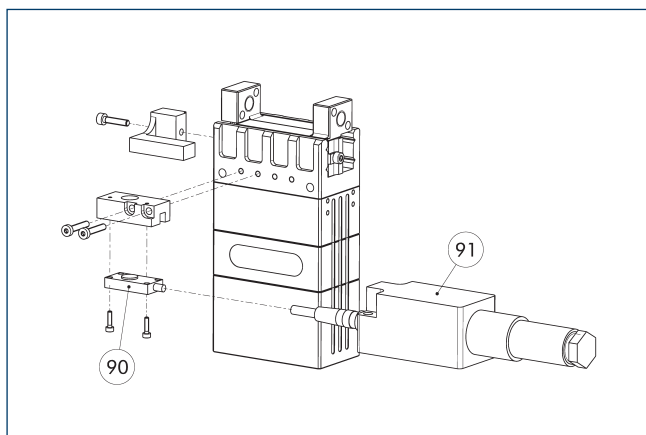

⑨⑩ FPS-S sensor

⑨① FPS-F5 evaluation electronic

Flexible position monitoring of up to five positions.

Description	ID	Often combined
Attachment kit for FPS		
AS-FPS-MPG 64	0301764	
Sensor		
FPS-S 13	0301705	
Evaluation electronics		
FPS-F5	0301805	●
Cable extension		
KV BG08-SG08 3P-0050	0301598	
KV BG08-SG08 3P-0100	0301599	

① When using an FPS system, an FPS sensor (FPS-S) as well as an electronic processor (FPS-F5 / F5 T) are required for each gripper as well as a mounting kit (AS), if listed. Cable extensions (KV) are optionally available – see catalog chapter “Accessories.”

Voltage supply/signals connection cable

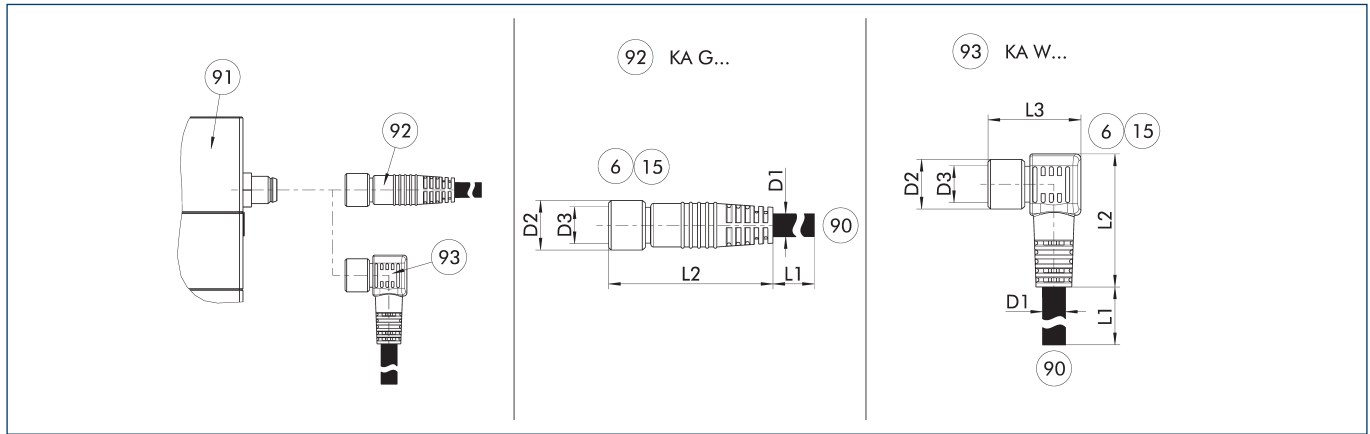

KA G... Connection cable with straight socket
 KA W... Connection cable with angular socket

- ⑥ Connection module side
- ⑬ Socket
- ⑨① Connection plug component
- ⑨② Cable with straight female connector
- ⑨③ Cable with angled female connector
- ⑨④ SAC connection cable with open wire strands

The connection cable is ideal for connecting the corresponding components to the controller or the power supply unit. The connection cable has a 4-pin M8 socket on one side and an open wire strand on the other side for individual connections. The connection cables are suitable for use both in the cable track as well as in torsion applications.

Description	ID	L1 [m]	D1 [mm]	L2 [mm]	D2 [mm]	L3 [mm]	D3	Often combined
Voltage supply/signals connection cable - drag chain and torsion resistant, M8 socket, straight								
KA GLN0804-10-00200-A	1310371	2	4.8	33.7	10		M8	
KA GLN0804-10-00500-A	1310375	5	4.8	33.7	10		M8	●
KA GLN0804-10-01000-A	1310379	10	4.8	33.7	10		M8	
KA GLN0804-10-02000-A	1442994	20	4.5	32	10		M8	
Voltage supply/signals connection cable - drag chain and torsion resistant, M8 socket, angled								
KA WLN0804-10-00200-A	1310372	2	4.8	27.9	10	18.9	M8	
KA WLN0804-10-00500-A	1310376	5	4.8	27.9	10	18.9	M8	
KA WLN0804-10-01000-A	1310381	10	4.8	27.9	10	18.9	M8	
KA WLN0804-10-02000-A	1442996	20	4.5	25	10	20	M8	

① Please observe the min. bending radius for cable track-compatible cables or the max. torsion angle for torsion-compatible cables. These are generally 10 times the cable diameter or +/- 180°/m.

Plug-in connector power supply/signals

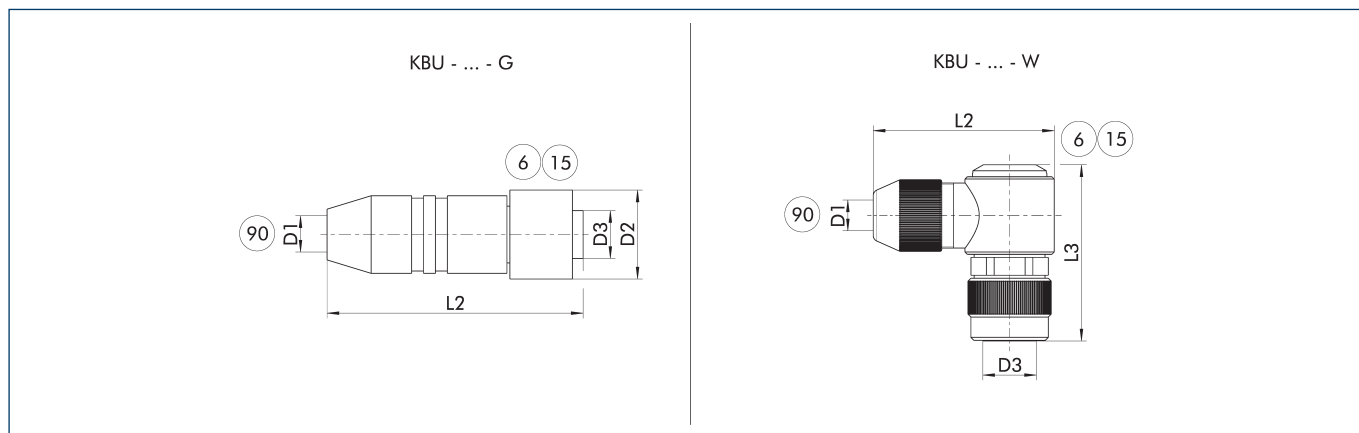

KBU - ... - G Socket with straight outlet

KBU - ... - W Socket with angular outlet

⑥ Connection module side

⑮ Socket

⑨⑩ D1 - max. diameter connection cable

The plug connectors are used to connect the SCHUNK products to the voltage supply. A customer cable can be used for this. The individual wire strands can be soldered to the solder pins of the connector.

Description	ID	D1 (max.) [mm]	L2 [mm]	D2 [mm]	L3 [mm]	D3
Cable connector						
KBU-M8-G 4P	1506418	5	37	12		M8
KBU-M8-W 4P	1506422	5	25		28	M8

① For the connection cable, a cross-section for each individual wire strand of 0.25 mm² is recommended. Please refer to the product documentation for information about max. cable length and min. wire cross section.

Connection cable for voltage supply and communication IO-Link

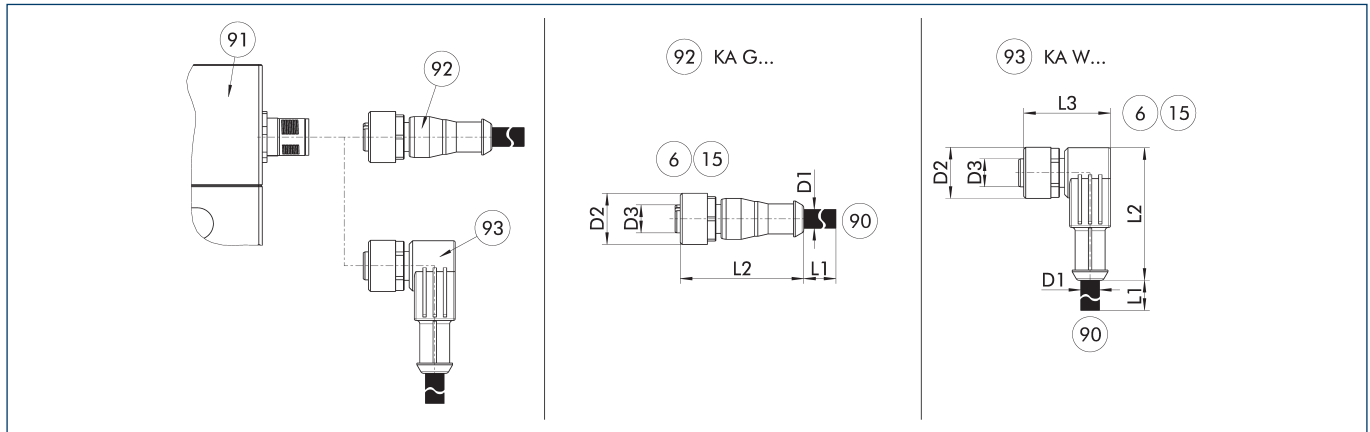

KA G... Connection cable with straight socket
 KA W... Connection cable with angular socket

- ⑥ Connection module side
- ⑬ Socket
- ⑨⑩ SAC connection cable with open wire strands
- ⑨① Connection plug component
- ⑨② Cable with straight female connector
- ⑨③ Cable with angled female connector

The connection cable is ideal for connecting the corresponding components to the control system. The connection cable has a 5-pin M12 socket on one side, and open wire strands on the other side for individual connections. The connection cables are suitable for use both in the cable track as well as in torsion applications.

Description	ID	L1 [m]	D1 [mm]	L2 [mm]	D2 [mm]	L3 [mm]	D3
IO-Link connection cable – drag chain and torsion-compatible							
KA GLN1205-IOL-00500-A	1387207	5	4.8	38	15		M12
KA GLN1205-IOL-01000-A	1387209	10	4.8	38	15		M12
KA WLN1205-IOL-00500-A	1387210	5	4.8	39	15	28	M12
KA WLN1205-IOL-01000-A	1387211	10	4.8	39	15	28	M12

① Please observe the min. bending radius for cable track-compatible cables or the max. torsion angle for torsion-compatible cables. These are generally 10 times the cable diameter or +/- 180°/m.

Cable extension for voltage supply and communication IO-Link

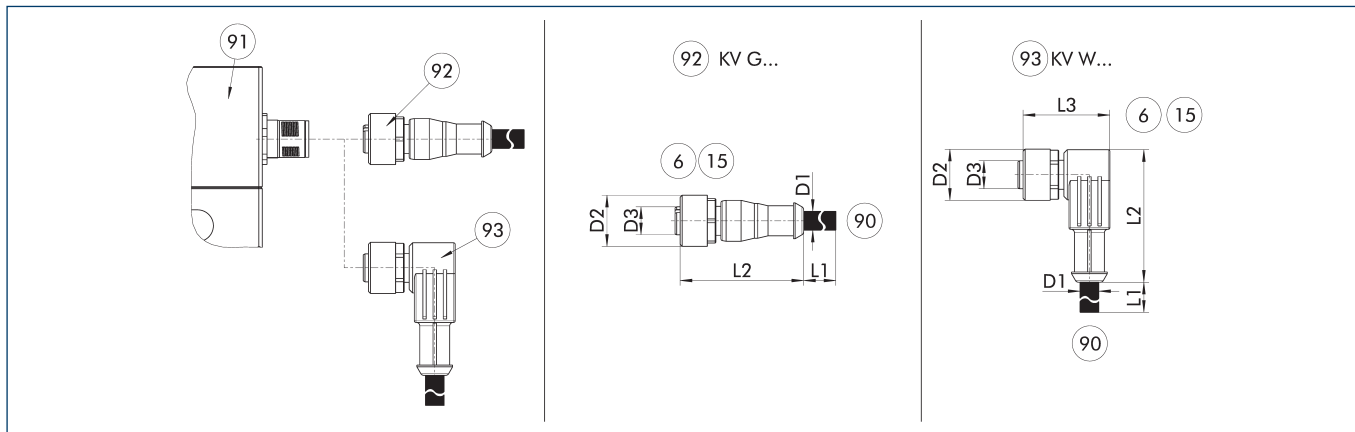

KV G... Cable extension with straight socket
 KV W... Cable extension with angled socket

⑥ Connection module side
 ⑮ Socket
 ⑨⑩ Cable end with straight connector

⑨① Connection plug component
 ⑨② Cable with straight female connector
 ⑨③ Cable with angled female connector

The cable extensions are ideal for connecting the relevant components to the control system, or for use as extension cables. The cable extensions have a 5-pin M12 connector with a straight or angled design on the module side and a 5-pin M12 plug with a straight design on the other side. The cable extensions are suitable for use in the cable track and in torsion applications.

Description	ID	L1 [m]	D1 [mm]	L2 [mm]	D2 [mm]	L3 [mm]	D3
IO-Link cable extension – cable track and torsion-compatible							
KV GGN1205-IO-00200-A	1387195	2	4.8	41	15		M12
KV GGN1205-IO-00500-A	1387199	5	4.8	41	15		M12
KV WGN1205-IO-00200-A	1387202	2	4.8	39	15	28	M12
KV WGN1205-IO-00500-A	1387205	5	4.8	39	15	28	M12

① Please observe the min. bending radius for cable track-compatible cables or the max. torsion angle for torsion-compatible cables. These are generally 10 times the cable diameter or +/- 180°/m.



SCHUNK SE & Co. KG

Spanntechnik

Greiftechnik

Automatisierungstechnik

Bahnhofstr. 106 - 134

D-74348 Lauffen/Neckar

Tel. +49-7133-103-0

Fax +49-7133-103-2399

info@de.schunk.com

schunk.com

Folgen Sie uns | *Follow us*

