



# Power Chuck

## ROTA THW3

### Assembly and Operating Manual

Translation of Original Operating  
Manual

## Imprint

### Copyright:

This manual is protected by copyright. The author is SCHUNK SE & Co. KG.  
All rights reserved.

### Technical changes:

We reserve the right to make alterations for the purpose of technical improvement.

**Document number:** 1440828

**Version:** 07.00 | 24/04/2024 | en

Dear Customer,

Thank you for trusting our products and our family-owned company, the leading technology supplier of robots and production machines.

Our team is always available to answer any questions on this product and other solutions. Ask us questions and challenge us. We will find a solution!

Best regards,

Your SCHUNK team

Customer Management

Tel. +49-7572-7614-1300

Fax +49-7572-7614-1039

cmm@de.schunk.com



**Please read the operating manual in full and keep it close to the product.**

## Table of Contents

<b>1 General .....</b>	<b>5</b>
1.1 About this manual.....	5
1.1.1 Illustration of warnings .....	5
1.1.2 Applicable documents .....	6
1.1.3 Sizes.....	6
1.2 Warranty .....	6
1.3 Scope of Delivery.....	6
<b>2 Basic safety notes.....</b>	<b>7</b>
2.1 Appropriate use .....	7
2.2 Inappropriate use .....	7
2.3 Structural changes.....	8
2.4 Spare parts .....	8
2.5 Ambient conditions and operating conditions .....	8
2.6 Material limitations .....	8
2.7 Chuck Jaws .....	9
2.8 Personnel qualifications .....	9
2.9 Personal protective equipment .....	10
2.10 Transport.....	10
2.11 Protection during handling and assembly .....	10
2.12 Protection during commissioning and operation .....	10
2.13 Notes on safe operation.....	11
2.14 Disposal .....	13
2.15 Fundamental dangers .....	13
2.16 Protection against dangerous movements .....	13
2.17 Notes on particular risks .....	14
<b>3 Technical data .....</b>	<b>17</b>
3.1 Chuck data .....	17
3.2 Clamping force–RPM diagrams .....	18
3.3 Calculations for clamping force and speed .....	22
3.3.1 Calculation of the required clamping force in case of a given rpm.....	22
3.3.2 Calculation example: required initial clamping force for a given speed ..	24
3.3.3 Calculation of the permissible speed in case of a given initial clamping force .....	25
3.4 Grades of Accuracy .....	25
3.5 Permissible imbalance .....	25
<b>4 Assembly.....</b>	<b>26</b>
4.1 Torques per screw .....	26

4.2	Installing and connecting .....	26
4.3	Connection thread draw tube .....	27
4.4	Checking the chuck mount .....	27
4.5	Assembly process .....	28
4.5.1	Chuck assembly (with cylindrical recess) .....	28
4.5.2	Assembly preparation for chuck with reduction or extension flange .....	31
<b>5</b>	<b>Function .....</b>	<b>32</b>
5.1	Function and handling .....	32
5.2	Base jaw position .....	33
5.3	Replacement or renewal of jaws .....	34
5.4	Functional testing .....	34
<b>6</b>	<b>Maintenance .....</b>	<b>35</b>
6.1	Lubrication .....	35
6.2	Technical condition .....	36
6.3	Maintenance intervals .....	37
6.4	Disassembling and assembling the chuck .....	38
<b>7</b>	<b>Storage .....</b>	<b>42</b>
<b>8</b>	<b>Part list .....</b>	<b>43</b>
<b>9</b>	<b>Drawing .....</b>	<b>45</b>

# 1 General

## 1.1 About this manual

This manual contains important information for the safe, correct use of the product.

It is an integral part of the product and must be kept accessible for personnel at all times.

Personnel must have read and understood this manual before beginning any work. The observance of all safety notes in this manual is a prerequisite to ensure safe work processes.

The illustrations are intended to provide a basic understanding and may deviate from the actual version.

Besides this manual, other documents which apply are those listed under ▶ 1.1.2 [ 6 ]

### 1.1.1 Illustration of warnings

To make risks clear, the following signal words and symbols are used for safety notes.



#### **⚠ DANGER**

Denotes a hazard with a high degree of risk that, if not avoided, will result in death or serious injury.



#### **⚠ WARNING**

Denotes a hazard with a medium degree of risk that, if not avoided, could result in death or serious injury.



#### **⚠ CAUTION**

Denotes a hazard with a low degree of risk that, if not avoided, could result in a minor or moderate injury.

#### **CAUTION**

Information about avoiding material damage.

### 1.1.2 Applicable documents

- General Terms and Conditions \*
- Calculation of the jaw centrifugal forces and jaw guidance load, in the "Technology" chapter of the lathe chuck catalog \* and the "Calculating the clamping force and RPM" chapter
- Brief operating instructions if available
- Approval drawings

The documents labeled with an asterisk (\*) can be downloaded from **schunk.com**.

### 1.1.3 Sizes

This operating manual applies to the following sizes:

- ROTA THW3 200-52
- ROTA THW3 225-66
- ROTA THW3 265-81
- ROTA THW3 315-104
- ROTA THW3 400-128
- ROTA THW3 500-165
- ROTA THW3 630-165

## 1.2 Warranty

The warranty for standard products is 24 months from the date of delivery from the factory, or 50,000 cycles\* for manually operated clamping devices and 500,000 cycles\* for power operated clamping devices. For special clamping devices, it is 12 months from the date of delivery from the factory, assuming appropriate use in accordance with the following conditions:

- Observe the applicable documents, ▶ 1.1.2 [ 6]
- Observance of the ambient conditions and operating conditions, ▶ 2.5 [ 8]
- Observance of the specified maintenance and lubrication intervals ▶ 6.1 [ 35]

Parts touching the workpiece and wearing parts are not part of the warranty.

\* One cycle comprises one complete clamping procedure ("opening" and "closing")

## 1.3 Scope of Delivery

- 1 Power lathe chuck in the version ordered
- 1 Set of base jaws
- 3 Mounting screws
- 1 Jaw change key
- 1 Eye bolt from size 225
- 1 Assembly key from size 265
- 1 Assembly and Operating Manual
- 1 Quick guide

## 2 Basic safety notes

Improper handling, assembly and maintenance of this product may result in risk to persons and equipment if this operating manual is not observed.

### 2.1 Appropriate use

- The product is used for clamping metal and plastic workpieces on machine tools.
- The product may only be used within the scope of its technical data.
- The product is intended for industrial and commercial use.
- Appropriate use of the product includes compliance with all instructions in this manual.
- The maximum speed and the necessary clamping force must be determined by the operator for each clamping task in accordance with the valid standards or technical specifications of the manufacturer.  
(See also "Calculation for clamping force and speed of rotation" in the chapter "Technical data").
- Use suitable top jaws with a suitable interface.
- The interference circuit diameter of the workpiece must be smaller or at most equal to the outer diameter of the clamping device.
- The workpiece must not experience plastic deformation under clamping force (clamping pressures are permissible).

### 2.2 Inappropriate use

The product is not being used appropriately if:

- the product is used as a press, a punch, a toolholder, a load-handling device or as lifting equipment.
- the specified technical data for use of the product are exceeded.
- workpieces are not properly clamped, paying particular attention to the specified clamping forces.
- the top jaws are not mounted properly.
- the product is not being operated properly.
- the product is operated in the stroke end positions.
- the guideways are overloaded due to the chuck jaws being too high or the clamping point being selected too high.
- the product has been insufficiently maintained.
- the product is brought into contact with aggressive media, especially acids.
- the product is used in abrasive blasting processes, especially sandblasting.

## 2.3 Structural changes

### Implementation of structural changes

Modifications, changes or reworking, e.g. additional threads, holes, or safety devices, can damage the product or impair its functionality or safety.

- Structural changes should only be made with the written approval of SCHUNK.

## 2.4 Spare parts

### Use of unauthorized spare parts

Using unauthorized spare parts can endanger personnel and damage the product or cause it to malfunction.

- Only use original spare parts and spares authorized by SCHUNK.

## 2.5 Ambient conditions and operating conditions

### Required ambient conditions and operating conditions

Incorrect ambient and operating conditions can make the product unsafe, leading to the risk of serious injuries, considerable material damage and/or a significant reduction in the service life of the product.

- Make sure that the product is only used within its defined application parameters.
- Ensure that the product is of a sufficient size for the application.
- Ensure that maintenance and lubricating intervals are observed.
- Only use cooling emulsions with anti-corrosive additives when machining.

Depending on the operating conditions, the function and clamping force must be checked after a certain period of operation.

With the smallest possible actuation pressure on the clamping cylinder, the base jaws should move evenly. This method is not a substitute for measuring the clamping force.

If the clamping force has dropped too much or if the base jaws and/or the release mechanism no longer move properly, the clamping device must be disassembled, cleaned, and relubricated.

## 2.6 Material limitations

The product is made of steel alloys, elastomers, aluminum alloys and brass. In addition, Linomax plus grease, Branotect anti-rust oil and Renolit HLT2 are incorporated into the product as auxiliary and operating materials. The safety data sheet for LINOMAX plus can be found at [www.schunk.com](http://www.schunk.com).



## 2.7 Chuck Jaws

### Requirements of the chuck jaws

Rotational or if applicable, accumulated energy, can make the product unsafe and risk the danger of serious injuries and considerable material damage.

- Change chuck jaws at a standstill and without a clamped workpiece.
- Do not use welded jaws.
- Design the chuck jaws to be as light and as low as possible. The clamping point must be as close as possible to the chuck face (clamping points at a greater distance lead to greater surface pressure in the jaw guidance and can significantly reduce the clamping force).
- If the clamping point is at a greater distance from the housing, the operating pressure must be reduced.
- After a collision, the clamping device and the chuck jaws must be subjected to a crack detection test before being used again. Replace damaged parts with original SCHUNK spare parts.
- The chuck jaw mounting screws and if present, the T-nuts, must be replaced if there are signs of wear or damage. Only use screws of quality grade 12.9 in compliance with the specified tightening torques. For clamping devices with fine serration, the jaw mounting screws must be screwed into the holes closest to the clamping point.

## 2.8 Personnel qualifications

### Inadequate qualification of personnel

Any work on the product by inadequately qualified personnel can lead to serious injuries and considerable material damage.

- All work must be performed by appropriately qualified personnel.
- Personnel must have read and understood the complete manual before beginning any work on the product.
- Observe country-specific accident prevention regulations and the general safety notes.

The following personnel qualifications are required for the various activities on the product:

<b>Qualified electrician</b>	Qualified electricians have the professional training, knowledge, and experience to work on electrical systems, to recognize and avoid potential dangers, and know the relevant standards and regulations.
<b>Specialist personnel</b>	Specialist personnel have the specialized training, knowledge, and experience to perform the tasks entrusted to them, to recognize and avoid potential dangers, and know the relevant standards and regulations.
<b>Instructed person</b>	Instructed persons have been instructed by the operator regarding the tasks entrusted to them and the potential dangers of inappropriate behavior.
<b>Manufacturer's service personnel</b>	The manufacturer's service personnel have the specialized training, knowledge, and experience to perform the work entrusted to them and to recognize and avoid potential dangers.

## 2.9 Personal protective equipment

### Use of personal protective equipment

Personal protective equipment serves to protect staff in the event of a danger that may interfere with their health or safety at work.

## 2.10 Transport

### Handling during transport

Incorrect handling during transport can make the product unsafe and risks the danger of serious injuries and considerable material damage.

- During transport and handling, secure the product to prevent it from falling.
- Use the transport thread on the clamping device.

## 2.11 Protection during handling and assembly

### Incorrect handling and assembly

Incorrect handling and assembly can make the product unsafe and can risk the danger of serious injuries and considerable material damage.

- All work must only be performed by appropriately qualified personnel.
- Secure the system against accidental operation during all work.
- Use suitable assembly and transport equipment and take precautions to prevent jamming and crushing.

## 2.12 Protection during commissioning and operation

### Falling or violently ejected components

Falling and ejected components can lead to serious injury or death.

- Take suitable protective measures to secure the danger zone.

## 2.13 Notes on safe operation

### Incorrect manner of working by personnel

An incorrect manner of working can make the product unsafe and risks serious injuries and considerable material damage.

- Observe the safety notes and assembly instructions.
- Do not expose the product to any corrosive media. Products for special ambient conditions are excluded.
- Rectify malfunctions as soon as they occur.
- Observe the care and maintenance instructions.
- Observe the current safety, accident prevention, and environmental protection regulations for the application field of the product.
- Do not start the machine spindle until the clamping force has built up on the chuck jaws and clamping has taken place in the permissible operating range.
- Unclamping may only occur once the machine spindle has come to a standstill.

### Functionality check

After installation of the clamping device, its function must be checked prior to commissioning.

#### Two important points are:

- **Clamping force:** At max. actuation force/pressure/torque, the clamping force specified for the clamping device must be reached.
- **Stroke control:** The stroke of the clamping piston must have a margin of safety at the front and back end positions. The machine spindle must not start up until the clamping piston has passed through this safety margin.

With manual clamping devices, stroke control is carried out via the indicator pin. Clamping is only correct if the indicator pin is countersunk and clamping force is applied to the workpiece.

When determining the clamping force required to machine a workpiece, the centrifugal force acting on the chuck jaws must be taken into account (according to VDI 3106). If the chuck jaws are changed, the stroke control will have to be adjusted to the new situation.

### Maintenance instructions

The clamping device's reliability and safety can only be guaranteed if the operator complies with the manufacturer's maintenance instructions.

- For lubrication, we recommend our tried and tested special grease, LINOMAX plus. Unsuitable lubricants can have a negative impact on the functioning of the clamping device (clamping

force, coefficient of friction, wear behavior). (For product information about LINOMAX plus, see the "Accessories" chapter of the SCHUNK lathe chuck catalog or contact SCHUNK.)

- Use a suitable high-pressure grease gun to ensure that you reach all the greasing areas.
- To ensure correct distribution of the grease, move the clamping device to its end positions several times, lubricate again, and then check the clamping force.
- Move the clamping device through to its end position several times after 500 clamping strokes, at the latest. This moves the lubricant back to the surfaces of the force transmission.
- Check the clamping device regularly for clamping force and jaw stroke.

**Clamping force measurement**

- Depending on the operating conditions, the function and clamping force must be checked after a certain period of operation. For this purpose, a calibrated clamping force meter (e.g. SCHUNK IFT) must be used. The loading conditions are shown below for the different chuck variants.

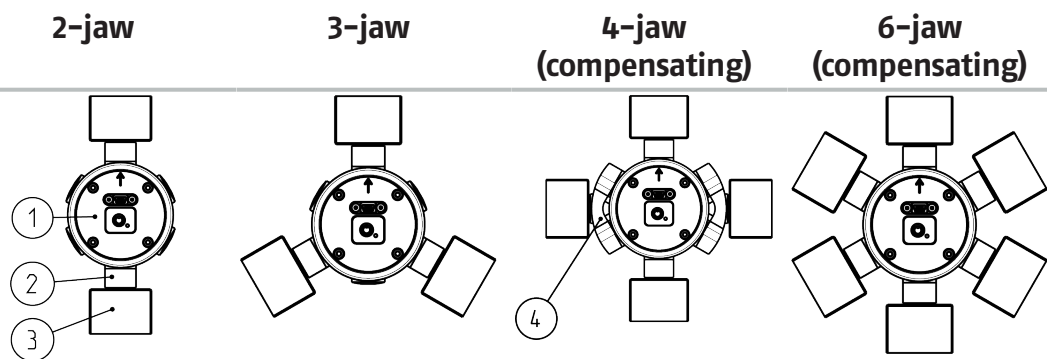

<b>Measuring device</b>	SCHUNK IFT clamping force tester	SCHUNK IFT clamping force tester	SCHUNK IFT clamping force tester	SCHUNK IFT clamping force tester
<b>Accessories</b>	-	-	IFT MA4	-
<b>Measuring points</b>	0°/180°	0°/120°/240°	0° / 180° / 90° / 270° (IFT MA4)	0°/60°/120°/180°/ 240°/300°
<b>Please note</b>	Operating manual SCHUNK IFT Clamping force tester	Operating manual SCHUNK IFT Clamping force tester	Operating manual SCHUNK IFT Clamping force tester	Operating manual SCHUNK IFT Clamping force tester

**Attention**  
 Compensation must be activated, otherwise it may lead to inconsistent results.

**Attention**  
 Compensation must be activated, otherwise it may lead to inconsistent results.

- ① Measuring head
- ② Clamping insert
- ③ Chuck jaw
- ④ Bridge element (IFT MA4)

- If the clamping force has dropped too much or if the base jaws and piston no longer move properly, the chuck will have to be disassembled, cleaned and relubricated.
- The clamping force should always be measured with the clamping device in the same condition as it is used in for the current clamping application. If top jaws with clamping steps are used, measuring must be performed in the same step as for the respective clamping task. In the event of high operating speeds, clamping force losses must be accounted for due to the centrifugal force acting on the chuck jaws. In this case the value of the operating clamping force should be measured dynamically.
- We recommend checking the clamping force using a clamping force tester before starting a new production run and between maintenance intervals. "Optimum safety can only be guaranteed through regular checks".

## 2.14 Disposal

### Handling of disposal

Incorrect handling of disposal can make the product unsafe and lead to risks of environmental harm.

- Follow local regulations on dispatching product components for recycling or proper disposal.

## 2.15 Fundamental dangers

### General

- Disconnect power sources before installation, modification or calibration. Ensure that no residual energy remains in the system.
- Do not reach into the open mechanism or movement area of the product during operation.

## 2.16 Protection against dangerous movements

### Unexpected movements

If the system still retains residual energy, serious injuries can be caused while working on the product.

- Switch off the energy supply, ensure that no residual energy remains and secure against inadvertent reactivation.
- Never rely merely on the response of the monitoring function to avert danger. Assume that the drive movement is faulty as long as the installed monitors are not effective, since the effect depends on the control and the current operating state of the drive.
- To avoid accidents and/or material damage, human access to the movement range of the machine must be restricted.

## 2.17 Notes on particular risks



### **⚠ DANGER**

**Risk of fatal injury to operating personnel due to the workpiece falling down or being flung out in the event of a power failure**

This poses a risk of death or injury to the operating personnel and can result in serious damage to the machine.



### **⚠ DANGER**

**Possible risk of death for the operating personnel in case of insufficient clamping force due to ejection or falling of the workpiece!**

Due to settling behavior, the clamping force may decrease over time.

- Re-clamping of the workpiece with manual or pneumatic clamping devices after 4 hours.
- The energy supply must be constantly applied to power-operated clamping devices during operation.
- Use clamping cylinders with energy conservation.



### **⚠ DANGER**

**Possible risk of death for operating personnel if the clamping device's top speed of rotation is exceeded and a workpiece is released or parts fly off.**

If the machine tool or the technical equipment can reach a higher speed than the maximum speed of the clamping device, the speed must be limited for safety purposes!



### **⚠ DANGER**

**Possible risk of death for operating personnel if a jaw breaks or if the clamping device fails because the technical data has been exceeded and a workpiece is released or parts fly off!**

- Never exceed the technical data specified by the manufacturer for using the clamping device.



### **⚠ DANGER**

**Possible risk of death for operating personnel from clothing or hair getting caught on the clamping device and being dragged into the machine!**

Loose clothing or long hair may become caught on projecting parts of the clamping device and be drawn into the machine.

- Always wear tight-fitting clothing and a hairnet when working on the machine and the lathe chuck.



### **⚠ WARNING**

**Possible risk of death for the operating personnel due to impact of the rotating clamping device!**

- Keep a safe distance to the rotating clamping device!
- Do not reach into the rotating clamping device!



### **⚠ CAUTION**

**Risk of limbs being crushed when opening and closing the chuck jaws during manual loading or unloading or when exchanging moving parts.**

- Do not reach between the chuck jaws.



### **⚠ CAUTION**

**Hazard from vibration due to imbalanced rotating parts and noise generation.**

Physical and mental strains due to imbalanced workpieces and noise during the machining process on the clamped and rotating workpiece.

- Ensure the clamping device's axial and concentric runout.
- Check options for remedying imbalances on special top jaws and workpieces.
- Reduce the speed.
- Wear hearing protection.



### **⚠ CAUTION**

**There is a risk of limbs being crushed by moving parts during manual loading and unloading and the clamping procedure.**

- Do not reach between the chuck jaws.
- Use loading devices.



### **⚠ CAUTION**

**Allergic reactions or irritation due to skin or eye contact with lubricants on the product.**

- In case of foreseeable contact with lubricants on the product (e.g. when lubricating or cleaning)
- Wear protective equipment (protective gloves, protective goggles)

### **CAUTION**

**Risk of damage due to incorrect choice of clamping position for chuck jaws on workpiece.**

If an incorrect clamping position is chosen for the chuck jaws on the workpiece, the base and top jaws may become damaged.

- Observe maximum positions of base and top jaws.
- The diameter of the workpiece must not be greater than the clamping device diameter.
- For clamping devices with fine serration, do not allow the T-nuts for connecting the top jaws to protrude beyond the base jaws in radial direction.
- The outer diameter of the screwed-on top jaws must not exceed the outer diameter of the clamping device by more than 10%.



## 3 Technical data

### 3.1 Chuck data

ROTA THW3	200	225	265	315	400	500	630
Max. actuating force [kN]	38	41	59	80	128	128	128
Max. clamping force [kN]	64	82	115	150	240	240	240
Max. speed [RPM]**	6000	5400	4000	3600	3000	2200	1700
Stroke per jaw [mm]	6.7	7.4	8.2	8.6	8.6	10.5	10.5
Piston stroke [mm]	17.5	21	24	25	25	30	30
Chuck bore [mm]	52	66	81	104	128	165	165
Centrifugal torque of base jaw $M_{cGB}^*$ [kgm]	0.048	0.095	0.198	0.457	0.503	1.550	2.225
Operating temperature	+15°C to +60°C						
Weight [kg]							
ISO 702-4 No. 5	18.6	-	-	-	-	-	-
ISO 702-1 No. 5	(19.6)	-	-	-	-	-	-
ISO 702-4 No. 6	-	25.1	-	-	-	-	-
ISO 702-1 No. 6	-	(26.1)	-	-	-	-	-
ISO 702-4 No. 8	-	-	43.3	58.1	-	-	-
ISO 702-1 No. 8	-	-	(46.3)	(61.1)	-	-	-
ISO 702-4 No. 11	-	-	-	-	103.2	-	-
ISO 702-1 No. 11	-	-	-	-	110.3	225.1	-
ISO 702-4 No. 15	-	-	-	-	-	199.1	-
ISO 702-1 No. 15	-	-	-	-	129.2	209.3	-
ISO 702-4 No. 20	-	-	-	-	-	-	292

\* The specified centrifugal torque of the base jaw has been calculated in the radially outermost position of the base jaw. For other positions, it is necessary to specifically determine this data. Calculation examples can be found in the "Technology" chapter of the SCHUNK lathe chuck catalog.

\*\* The maximum RPM stated is only valid with the maximum clamping force and when using the hard standard chuck jaws that go with the chuck. The maximum permissible speed of rotation for the specific machining has to be defined by the user on the basis of the required clamping forces. This speed of rotation must not exceed the maximum speed of rotation of the lathe chuck.

Ensure minimal weight for all jaws.

For unhardened top jaws or special chuck jaws, the permissible speed of rotation according to VDI 3106 must be determined by means of calculation for the respective machining job whereby the maximum recommended speed must not be exceeded. The calculated values must be verified by means of a dynamic measurement. Function monitoring (piston movement and actuating pressure) must be performed in accordance with the guidelines of the Berufsgenossenschaft (employers' mutual insurance association).

### 3.2 Clamping force–RPM diagrams

Clamping force/RPM curves have been calculated using the corresponding standard top jaws (stepped jaws and monoblock jaws). In the determination process, the maximum actuating force was applied and the jaws were set flush with the outer diameter of the chuck.

The chuck is in perfect condition and lubricated with SCHUNK LINOMAX plus special grease.

If one or more of these prerequisites is modified, the graphs will no longer be valid.

#### Chuck setup for clamping force/RPM diagram

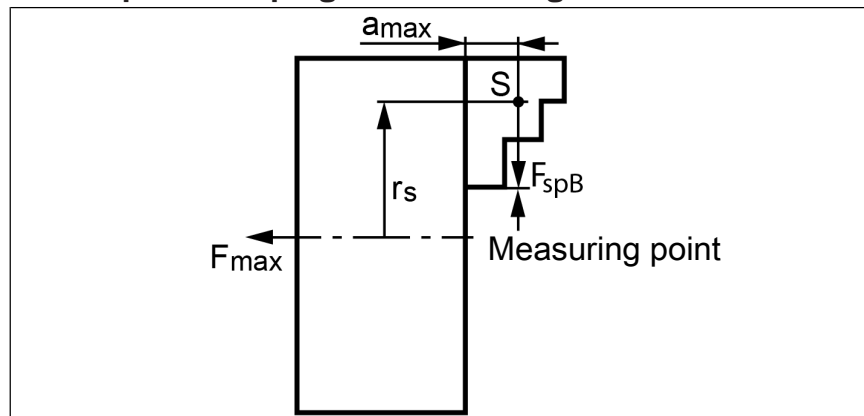

$F_{spB}$	Jaw clamping force	S	Center of gravity
$r_s$	Radius of center	$a_{max}$	Max. jaw eccentricity of center of gravity in axial direction
$F_{max}$	Max. actuating force		



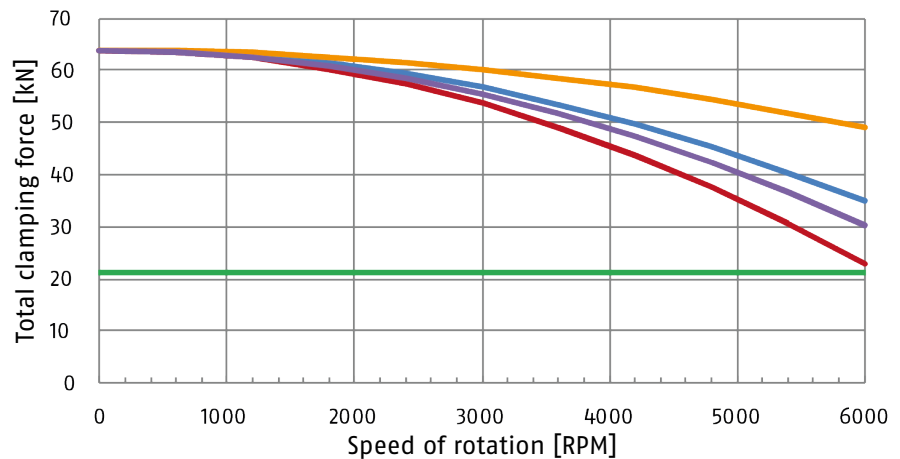



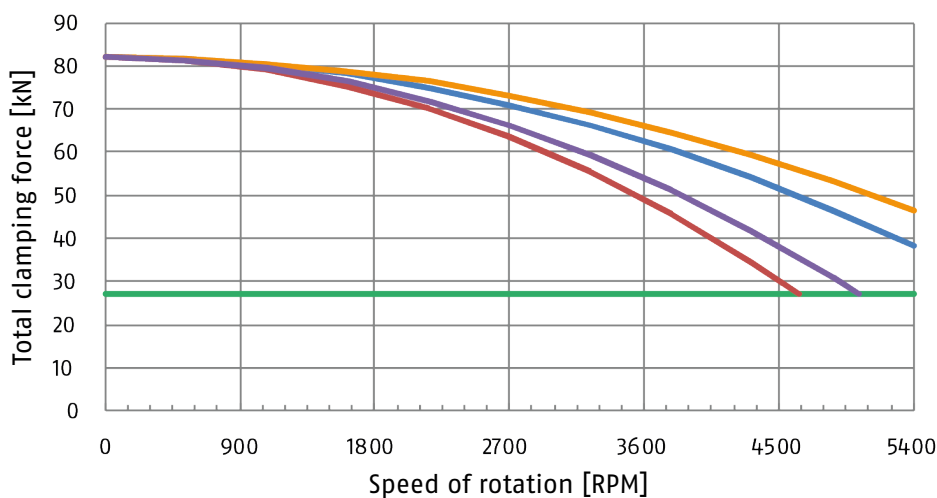

#### Clamping force/RPM diagram for ROTA THW3 200–52



Colour	Jaw ID	Weight [kg]
	SHF 160	0,6
	SFA 160	1,2
	GST 140	0,7
	UVB 160	1,6
	Minimum required clamping force 33%	







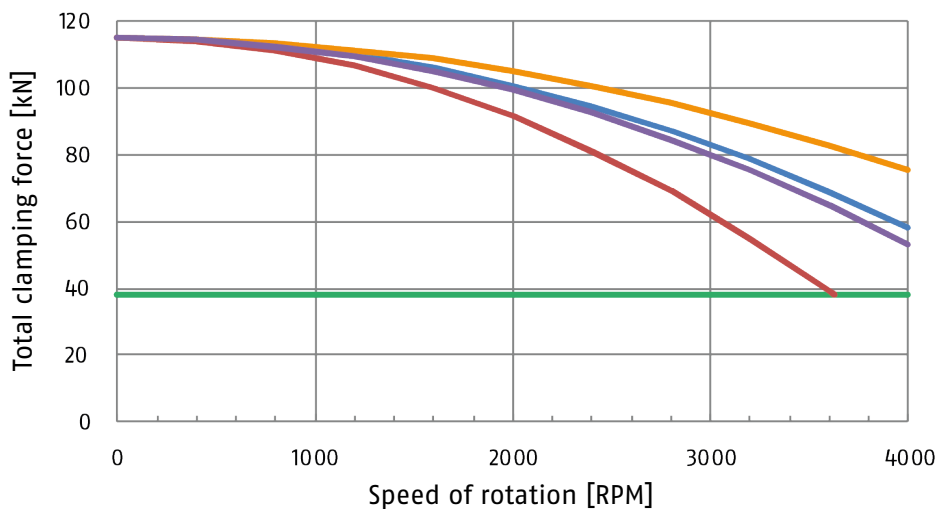

### Clamping force/RPM diagram for ROTA THW3 225-66



Colour	Jaw ID	Weight [kg]
	 SHF 200	0,8
	 SFA 200	2,0
	 GST 201	1,6
	 UVB 200	2,7
	Minimum required clamping force 33%	







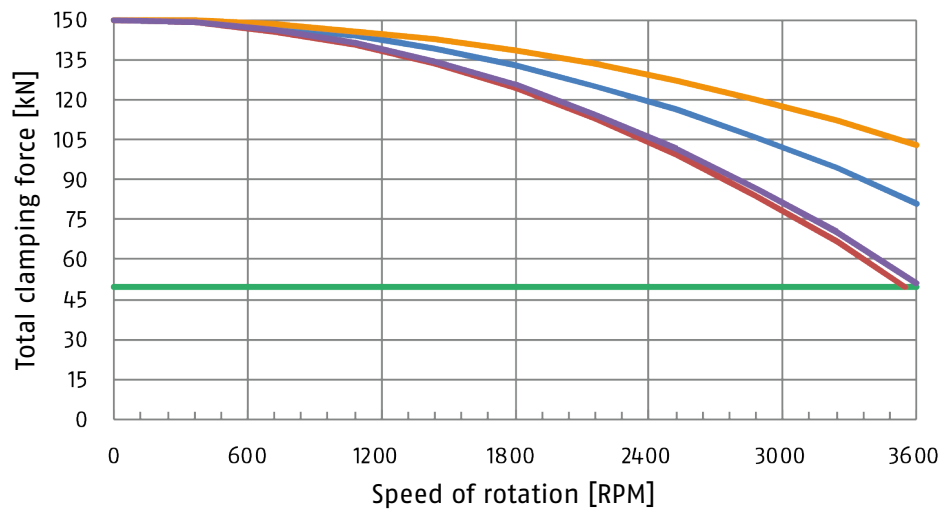

### Clamping force/RPM diagram for ROTA THW3 265-81



Colour	Jaw ID	Weight [kg]
	 SHF 250	1,9
	 SFA 250	3,7
	 GST 251	2,8
	 UVB 250	4,8
	Minimum required clamping force 33%	







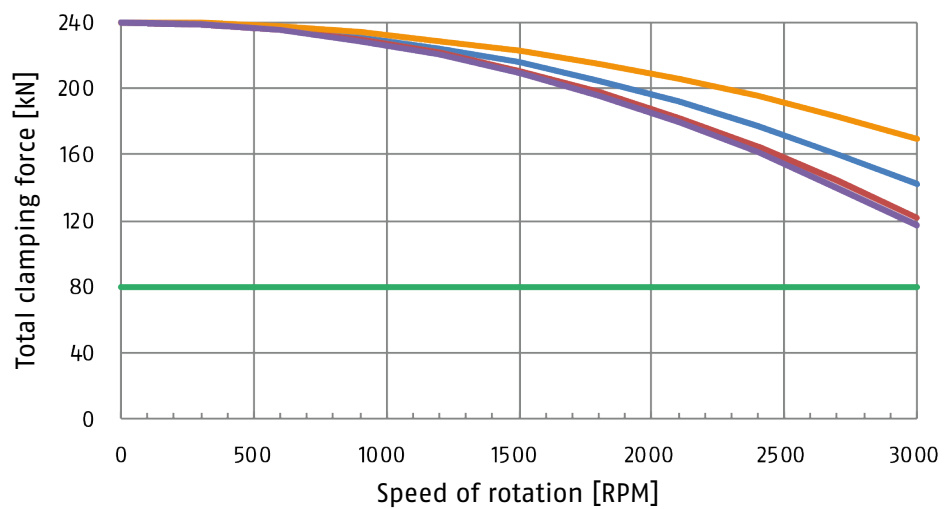

### Clamping force/RPM diagram for ROTA THW3 315-104



Colour	Jaw ID	Weight [kg]
	 SHF 250	1,9
	 SFA 250	3,7
	 GST 315	3,5
	 UVB 315	7,6
	Minimum required clamping force 33%	







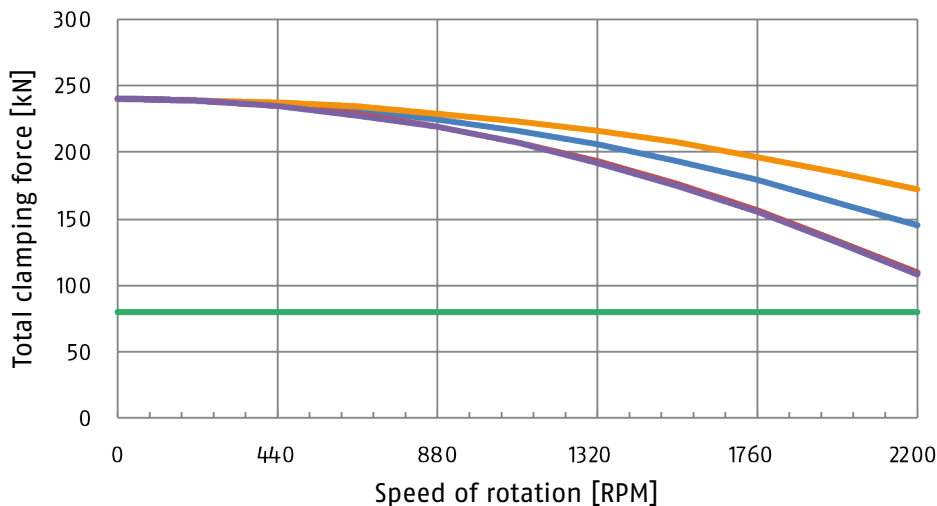

### Clamping force/RPM diagram for ROTA THW3 400-128



Colour	Jaw ID	Weight [kg]
	 SHF 315	3,3
	 SFA 315	5,6
	 GST 400	4,6
	 UVB 400	10,0
	Minimum required clamping force 33%	







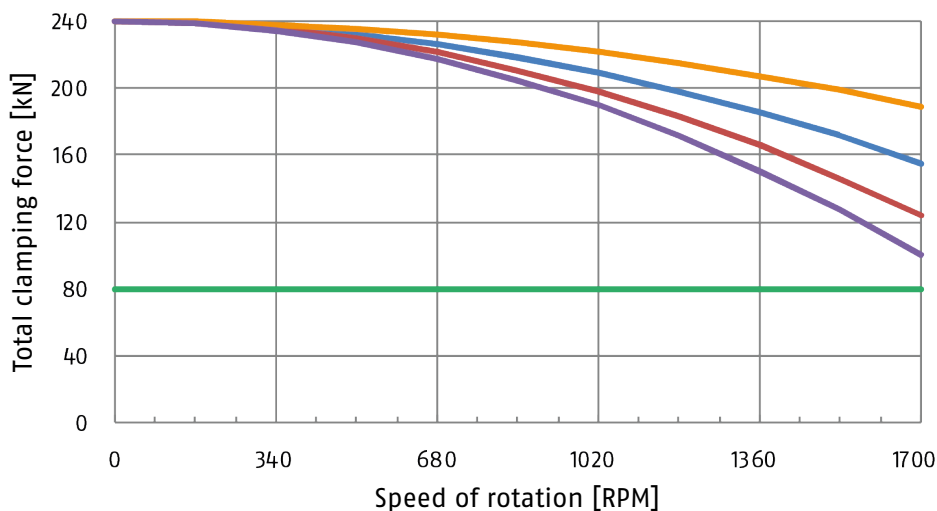

### Clamping force/RPM diagram for ROTA THW3 500-165



Colour	Jaw ID	Weight [kg]
	 SHF 400	6,8
	 SFA 400	13,5
	 GST 500-630	11,7
	 UVB 500	20,3
	Minimum required clamping force 33%	

### Clamping force/RPM diagram for ROTA THW3 630-165



Colour	Jaw ID	Weight [kg]
	 SHF 400	6,8
	 SFA 400	13,5
	 GST 500-630	11,7
	 UVB 630	31,0
	Minimum required clamping force 33%	

### 3.3 Calculations for clamping force and speed

Missing information or specifications can be requested from the manufacturer.

#### Legend

$F_c$	Total centrifugal force [N]	$M_{cAB}$	Centrifugal torque of top jaws [Kgm]
$F_{sp}$	Effective clamping force [N]	$M_{cGB}$	Centrifugal torque of base jaws [Kgm]
$F_{spmin}$	Minimum required clamping force [N]	$n$	Speed [rpm]
$F_{sp0}$	Initial clamping force [N]	$r_s$	Center of gravity radius [m]
$F_{spz}$	Cutting force [N]	$r_{sAB}$	Center of gravity radius of top jaw [m]
$m_{AB}$	Mass of one top jaw [kg]	$s_{sp}$	Safety factor for clamping force
$m_B$	Mass of chuck jaw set [kg]	$s_z$	Safety factor for machining
$M_c$	Centrifugal force torque [Kgm]	$\Sigma_s$	Max. clamping force of chuck [N]

#### 3.3.1 Calculation of the required clamping force in case of a given rpm

The initial clamping force  $F_{sp0}$  is the total force impacting radially on the workpiece via the jaws due to actuation of the lathe chuck during shutdown. Under the influence of rotation, the jaw mass generates an additional centrifugal force. The centrifugal force reduces or increases the initial clamping force depending on whether gripping is from the outside inwards or from the inside outwards.

The sum of the initial clamping force  $F_{sp0}$  and the total centrifugal force  $F_c$  is the effective clamping force  $F_{sp}$ .

$$F_{sp} = F_{sp0} \mp F_c \text{ [N]}$$

(-) for gripping from the outside inwards

(+) for gripping from the inside outwards



#### **! DANGER**

Risk to life and limb of the operating personnel and significant property damage when the RPM limit is exceeded! With gripping from the outside inwards, and with increasing RPM, the effective clamping force is reduced by the magnitude of the increasing centrifugal force (the forces are opposed). When the RPM limit is exceeded, the clamping force drops below the required minimum clamping force  $F_{spmin}$ . Consequently, the workpiece is released spontaneously.

- Do not exceed the calculated RPM.
- Do not fall below the necessary minimum clamping force.

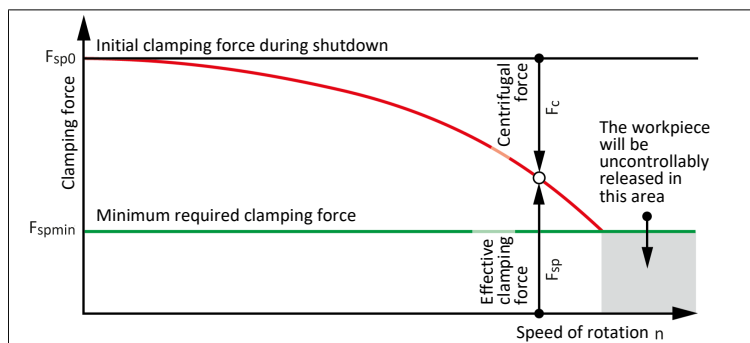

Reduction in effective clamping force by the magnitude of the total centrifugal force, for gripping from the outside inwards.

The required effective clamping force for machining  $F_{sp}$  is calculated from the product of the **machining force**  $F_{spz}$  and the **safety factor**  $S_z$ . This factor takes into account uncertainties in the calculation of the machining force. According to VDI 3106:  $S_z \geq 1.5$ .

$$F_{sp} = F_{spz} \cdot S_z \text{ [N]}$$

From this we can derive the calculation of the initial clamping force during shutdown:

$$F_{sp0} = S_{sp} \cdot (F_{sp} \pm F_c) \text{ [N]}$$

(+) for gripping from the outside inwards

(-) for gripping from the inside outwards

### CAUTION

**This calculated force must not be larger than the maximum clamping force  $\Sigma S$  engraved on the lathe chuck.**

See also "Lathe chuck data" table ▶ 3.1 [17]

From the above formula it is evident that the sum of the effective clamping force  $F_{sp}$  and the total centrifugal force  $F_c$  is multiplied by the **safety factor for the clamping force**  $S_{sp}$ . According to VDI 3106, the following also applies here:  $S_{sp} \geq 1.5$ .

The **total centrifugal force**  $F_c$  is dependent on both the sum of the masses of all jaws and on the center of gravity radius and the rpm.

### CAUTION

**For safety reasons, in accordance with DIN EN 1550, the centrifugal force may be a maximum of 67% of the initial clamping force.**

The formula for the calculation of the total centrifugal force  $F_c$  is:

$$F_c = \sum(m_B \cdot r_s) \cdot \left(\frac{\pi \cdot n}{30}\right)^2 = \sum M_c \cdot \left(\frac{\pi \cdot n}{30}\right)^2 \text{ [N]}$$

For this, **n is the given speed of rotation** in RPM. The product  $m_B \cdot r_s$  is referred to as the **centrifugal torque**  $M_c$ .

$$M_c = m_B \cdot r_s \text{ [kgm]}$$

In case of toolholders with split chuck jaws, i.e., with base jaws and top jaws, for which the base jaws change their radial position only by the stroke amount, the **centrifugal torque of the base jaws**  $M_{cGB}$  and the **centrifugal torque of the top jaws**  $M_{cAB}$  need to be added:

$$M_c = M_{cGB} + M_{cAB} \text{ [kgm]}$$

The centrifugal torque of the base jaws  $M_{cGB}$  can be found in the table "Lathe chuck data" ▶ 3.1 [17]. The centrifugal torque of the top jaws  $M_{cAB}$  is calculated as per:

$$M_{cAB} = m_{AB} \cdot r_{sAB} \text{ [kgm]}$$

### 3.3.2 Calculation example: required initial clamping force for a given speed

#### Required initial clamping force $F_{sp0}$ for a given RPM $n$

The following data is known for the machining job:

- Gripping from the outside in (application-specific)
- Machining force  $F_{spz} = 3000$  N (application-specific)
- max. RPM  $n_{max} = 3200$  RPM ("Lathe chuck data" table)
- RPM  $n = 1200$  RPM (application-specific)
- Mass of one (!) top jaw  $m_{AB} = 5.33$  kg (application-specific)
- Center of gravity radius of top jaw  $r_{sAB} = 0.107$  m (application-specific)
- Safety factor  $S_z = 1.5$  (according to VDI 3106)
- Safety factor  $S_{sp} = 1.5$  (according to VDI 3106)

**Note:** Masses of the jaw mounting screws and T-nuts are not taken into account.

First the required effective clamping force  $F_{sp}$  is calculated using the machining force stated:

$$F_{sp} = F_{spz} \cdot S_z = 3000 \cdot 1.5 \Rightarrow \mathbf{F_{sp} = 4500 \text{ N}}$$

Initial clamping force during shutdown:

$$F_{sp0} = S_{sp} \cdot (F_{sp} + F_c)$$

Calculation of total centrifugal force:

$$F_c = \sum M_c \cdot \left(\frac{\pi \cdot n}{30}\right)^2$$

For two-part chuck jaws, the following applies:

$$M_c = M_{cGB} + M_{cAB}$$

Take the centrifugal torque of the base jaw and top jaw specified from the "Lathe chuck data" table:

$$\mathbf{M_{cGB} = 0.319 \text{ kgm}}$$

For the centrifugal torque of the top jaw, the following applies:

$$M_{cAB} = m_{AB} \cdot r_{sAB} = 5.33 \cdot 0.107 \Rightarrow \mathbf{M_{cAB} = 0.57 \text{ kgm}}$$

Centrifugal torque for one jaw:

$$M_c = 0.319 + 0.571 \Rightarrow \mathbf{M_c = 0.89 \text{ kgm}}$$

The chuck has 3 jaws, the total centrifugal torque is:

$$\sum M_c = 3 \cdot M_c = 3 \cdot 0.889 \Rightarrow \sum \mathbf{M_c = 2.667 \text{ kgm}}$$

The total centrifugal force can now be calculated:

$$F_c = \sum M_c \cdot \left(\frac{\pi \cdot n}{30}\right)^2 = 2.668 \cdot \left(\frac{\pi \cdot 1200}{30}\right)^2 \Rightarrow \mathbf{F_c = 42131 \text{ N}}$$

Initial clamping force during shutdown that was sought:

$$F_{sp0} = S_{sp} \cdot (F_{sp} + F_c) = 1.5 \cdot (4500 + 42131) \Rightarrow \mathbf{F_{sp0} = 69947 \text{ N}}$$



### 3.3.3 Calculation of the permissible speed in case of a given initial clamping force

Calculation of the permissible RPM  $n_{perm}$  in case of a given initial clamping force  $F_{sp0}$

The following formula can be used to calculate the permissible RPM for a given initial clamping force during shutdown:

$$n_{zul} = \frac{30}{\pi} \cdot \sqrt{\frac{F_{sp0} - (F_{spz} \cdot S_z)}{\sum M_c}} \quad [\text{min}^{-1}]$$

#### CAUTION

**For safety reasons, the calculated permissible RPM may not exceed the maximum RPM inscribed on the lathe chuck!**

**Example of calculation: Permissible RPM for a given effective clamping force**

The following data is known from previous calculations:

- Initial clamping force during shutdown  $F_{sp0} = 17723 \text{ N}$
- Machining force for machining job  $F_{spz} 3000 \text{ N}$  (application-specific)
- Total centrifugal torque of all jaws  $\sum M_c = 2,668 \text{ kgm}$
- Safety factor  $S_z = 1.5$  (according to VDI 3106)
- Safety factor  $S_{sp} = 1.5$  (according to VDI 3106)

#### NOTE:

Masses of the jaw mounting screws and T-nuts are not taken into account.

Identifying the permissible RPM:

$$n_{zul} = \frac{30}{\pi} \cdot \sqrt{\frac{F_{sp0} - (F_{spz} \cdot S_z)}{\sum M_c}} = \frac{30}{\pi} \cdot \sqrt{\frac{69947 - (3000 \cdot 1.5)}{2.668}} \Rightarrow n_{zul} = 1495 \text{ min}^{-1}$$

The calculated RPM  $n_{perm} = 1495 \text{ RPM}$  is smaller than the maximum permissible RPM of the lathe chuck  $n_{max} = 3200 \text{ RPM}$  (see "Lathe chuck data" table ▶ 3.1 [17]).

**This calculated RPM may be used.**

### 3.4 Grades of Accuracy

Tolerances for radial and axial run-out accuracy correspond to the Technical Supply Terms for lathe chucks as per DIN ISO 3442-2.

### 3.5 Permissible imbalance

The ROTA THW3 in ungreased state without top jaws corresponds to the balancing quality class 6.3 (according to DIN ISO 21940-11). Residual imbalance risks may arise due to insufficient rotation compensation being achieved (see DIN EN ISO 21940-11). This applies particularly to high RPM, asymmetrical workpieces or the use of various top jaws, as well as uneven lubrication. In order to prevent damage resulting from these residual risks, the entire rotor must be dynamically balanced in accordance with DIN ISO 21940-11.

## 4 Assembly

### 4.1 Torques per screw

**Tightening torques for mounting screws used to clamp the chuck on lathes or other suitable technical equipment (screw quality 10.9)**

Screw size	M6	M8	M10	M12	M14	M16	M18	M20	M22	M24	M27	M30
Tightening torques $M_A$ (Nm)	13	28	50	88	120	160	200	290	400	500	1050	1500

Screw size	7/16"	1/2"	5/8"	3/4"	7/8"	1"
Tightening torques $M_A$ (Nm)	50	88	160	290	400	500

**Tightening torques for mounting screws used to attach top jaws onto the lathe chuck (screw quality 12.9)**

Screw size	M6	M8	M10	M12	M16	M20	M24
Tightening torques $M_A$ (Nm)	16	25	60	80	100	180	230

### 4.2 Installing and connecting



#### **⚠ WARNING**

**Risk of injury due to unexpected movements!**

If the power supply is switched on or residual energy remains in the system, components can move unexpectedly and cause serious injuries.

- Before starting any work on the product: Switch off the power supply and secure against restarting.
- Make sure, that no residual energy remains in the system.

1. Check the connection thread or adapter.
2. Checking the spindle nose for mounting the chuck flange ▶ 4.4 [ 27]
3. Chuck assembly
  - ⇒ Chuck assembly (with cylindrical recess) ▶ 4.5.1 [ 28] if required:
  - ⇒ Assembly preparation for the chuck with reduction or expansion adapter plate ▶ 4.5.2 [ 31]
4. Performing a functional check
  - ▶ 5.4 [ 34]

### 4.3 Connection thread draw tube

The chuck and draw tube are connected via a thread. The following requirements must be met on the draw tube side. If they cannot be attached directly to the draw tube, an adapter must be used.

Size	A	B	C	D	E	F	G	O-ring
ROTA THW3 200-52	M64 x 1.5	13.0	52	62.0	2.4	58	3.5	62 x 1.5
ROTA THW3 225-66	M78 x 1.5	13.0	66	76.0	2.4	70	3.5	76 x 1.5
ROTA THW3 265-81	M90 x 2.0	16.0	81	87.4	2.4	84	-	86 x 2.0
ROTA THW3 315-104	M115 x 2.0	18.0	104	109.5	3.2	107	-	110 x 3.0
ROTA THW3 400-128	M140 x 2.0	20.1	128	135.0	3.2	131	-	135 x 3.0
ROTA THW3 500-165	M175 x 2.0	20.1	165	170	3.2	168	-	170 x 3.0
ROTA THW3 630-165	M175 x 2.0	20.1	165	170	3.2	168	-	170 x 3.0

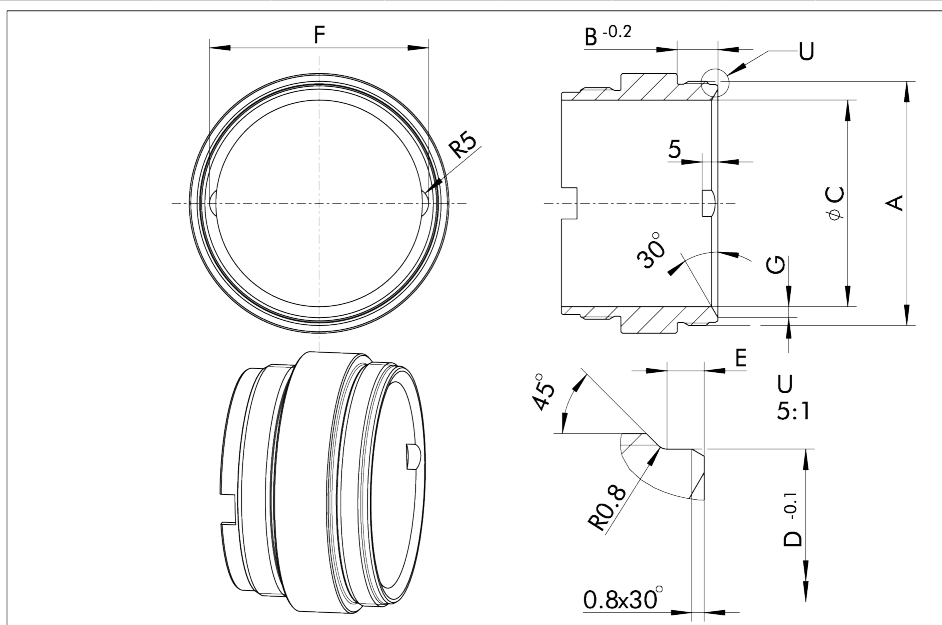

### 4.4 Checking the chuck mount

The machine side must be aligned prior to the flange being installed in order to achieve high run-out accuracy of the chuck. To do this, check the contact surfaces on the spindle for axial and radial run-out accuracy using a dial indicator.

**There should be a maximum concentricity error in the centering of the mount of 0.01 mm and a maximum axial run-out error in the contact surfaces of 0.01 mm. The flat surface of the spindle must also be checked for flatness using a straight edge. Make sure that the surface area of the flat surface is deburred at the bore holes and is clean.**

## 4.5 Assembly process

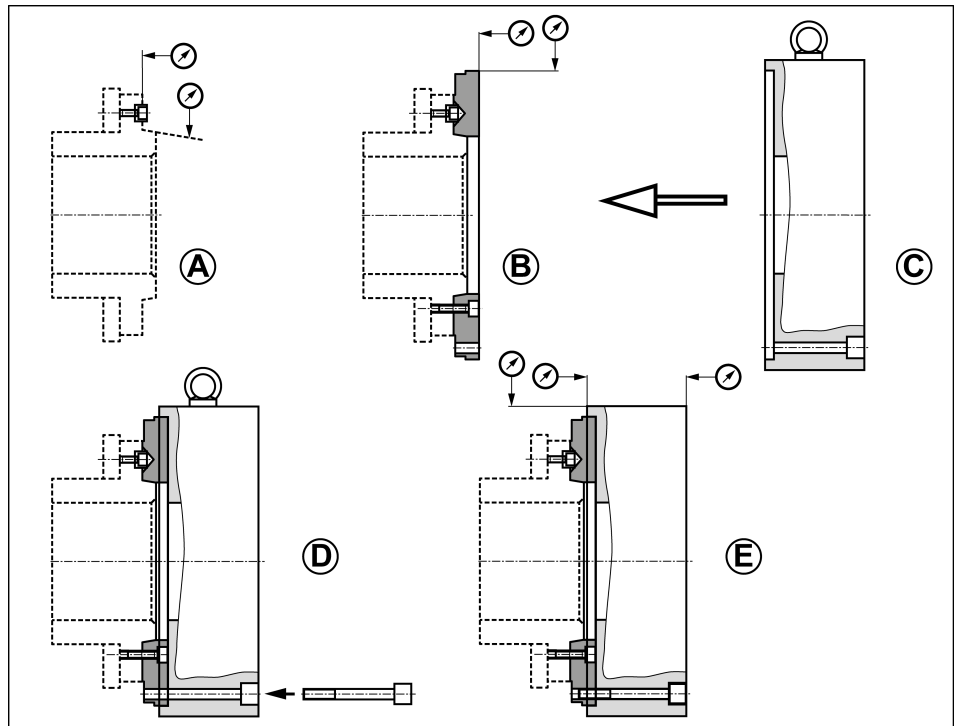

Lathe chuck assembly

- Chuck assembly (with cylindrical recess) ▶ 4.5.1 [ 28]
  - ⇒ Assembly preparation for the chuck with reduction or expansion adapter plate ▶ 4.5.2 [ 31]

### 4.5.1 Chuck assembly (with cylindrical recess)

#### NOTE

If the mount of the machine spindle and the lathe chuck are identical, chuck assembly takes place without assembly preparation.

If the mount of the machine spindle differs from that of the lathe chuck, a connecting flange must be affixed before the chuck is assembled, (See ▶ 4.5.2 [ 31]).

#### CAUTION

Use a crane to install the lathe chuck. The chuck can be fastened to the eye bolt provided (see Fig. "Lathe chuck assembly" - C).

The eye bolt must be removed prior to commissioning.

The eye bolt is included in the scope of delivery (from size 225).

#### Chuck assembly

- Move the draw tube to its foremost position by actuating the clamping cylinder
  - Piston in foremost position
  - R1 = Push the chuck piston to its foremost position and

measure with a depth gauge.

$$R2 = R1 + 0.3 \text{ mm}$$

(max. + 0.5 mm)

**Ensure that the piston can be moved to its foremost position (jaw change). To do this, ensure that the dimensions for the attachment are complied with.**

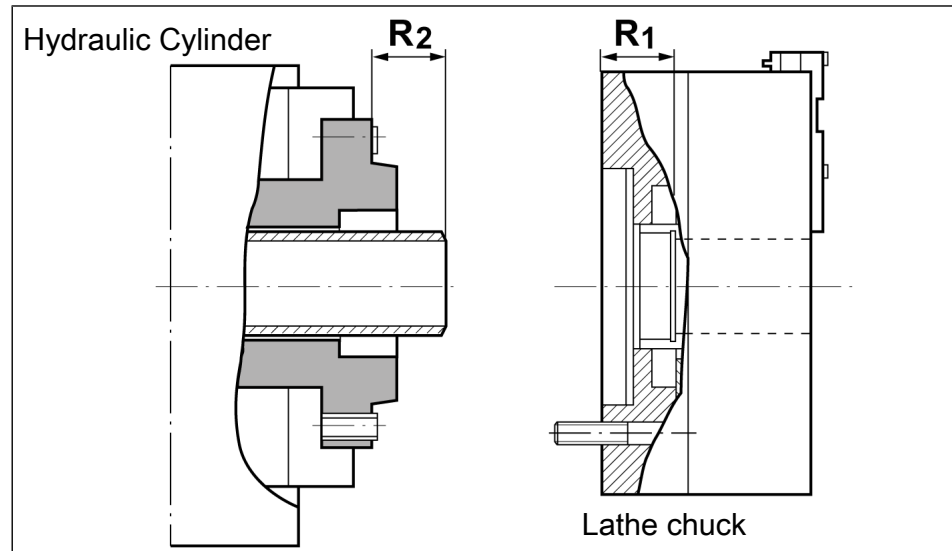

- Push the chuck piston to its foremost position.

### CAUTION

**Due to the seal, an air cushion can form in the chuck, which prevents the piston from remaining in the forward position.**

This can be remedied by venting the chuck ▶ 6.1 [□ 35].

### CAUTION

**Due to the seal, an air cushion can form in the chuck, which can disrupt the jaw change mechanism.**

This can be remedied by venting the chuck ▶ 6.1 [□ 35].

### Chucks in sizes 200 and 225

- Offset the base jaws (item 22) so that they do not project over the outer edge of the chuck.
- Rotate the entire chuck on the draw tube (bar).
- Slightly tighten the supplied chuck mounting screws (item 31) alternately to attach the chuck to the spindle nose.
- Check the chuck for concentricity and axial run-out accuracy (see ▶ 4.5 [□ 28]) and, if necessary, align at the outer diameter with gentle taps using a hammer.
- Tighten the mounting screws (item 31) with a torque wrench. Observe the maximum admissible torques ▶ 4.1 [□ 26].

- Check the chuck again for concentricity and axial run-out accuracy (see ▶ 4.5 [□ 28]). The "Concentricity and axial run-out tolerances" table shows the concentricities and axial run-out accuracies to be achieved.
- Check the actuating force is functioning and is sufficiently large.
- Move the clamping cylinder to the foremost position. Unlock the jaw connection with the supplied jaw change key (item 20) and insert or offset the base jaws into the chuck's jaw guidance as shown on markings 1, 2 or 3.
- Check that the base jaws can move easily and check the jaw stroke.

### **Chucks in size 265 or above**

- Offset the base jaws (item 22) up to the outermost marking of the chuck face.
- Lift the chuck to in front of the spindle lug using an eye bolt flush to the center of the spindle.
- Screw the rotating center sleeve (item 14) onto the draw tube as far as the stop using the supplied assembly key (item 23).
- Slightly tighten the supplied chuck mounting screws (item 31) alternately to attach the chuck to the spindle nose.
- Check the chuck for concentricity and axial run-out accuracy (see ▶ 4.5 [□ 28]) and, if necessary, align at the outer diameter with gentle taps using a hammer.
- Tighten the mounting screws (item 31) with a torque wrench. Observe the maximum admissible torques ▶ 4.1 [□ 26].
- Check the chuck again for concentricity and axial run-out accuracy (see ▶ 4.5 [□ 28]). The "Concentricity and axial run-out tolerances" table shows the concentricities and axial run-out accuracies to be achieved.
- Check the actuating force is functioning and is sufficiently large.
- Move the clamping cylinder to the foremost position. Unlock the jaw connection with the supplied jaw change key (item 20) and insert or offset the base jaws into the chuck's jaw guidance as shown on markings 1, 2 or 3.
- Check that the base jaws can move easily and check the jaw stroke.

**At regular intervals, check that the retainer ring (item 15) is seated firmly.**

The parts are disassembled in the same way but in the reverse order.

### Concentricity and axial run-out tolerances

Chuck size [mm]	max. concentricity error [mm]	max. axial run-out error [mm]
200	0.02	0.02
225	0.02	0.02
265	0.03	0.03
315	0.03	0.03
400	0.03	0.03
500	0.04	0.04
630	0.04	0.04

#### 4.5.2 Assembly preparation for chuck with reduction or extension flange

If the bolt pitch circle of the machine spindle does not correspond to the bolt pitch circle of the lathe chuck, a reduction or expansion adapter plate must be used.

- Before assembly of the chuck flange, remove any dirt or chips from the machine spindle and from the centering mount and contact surface of the flange.
- A chuck flange produced by the user must be fully machined on the machine spindle and balanced before assembly of the chuck.
- After assembly, ensure that the flange is in contact with the entire surface.
- Check the concentricity and axial run-out of the flange (see Fig. ▶ 4.5 [📄 28]).
- Then the chuck is assembled ▶ 4.5.1 [📄 28].

## 5 Function

### 5.1 Function and handling

The lathe chucks of type ROTA THW3 are actuated using rotating closed-center or open-center hydraulic cylinders or via a static hydraulic cylinder. The axial tensile and pressure forces are converted to the radial jaw clamping force by the wedge angle in the pistons and thrust jaw.

The clamping and opening path of the chuck jaws is determined by the clamping cylinder. The base jaws with screwed-on top jaws are moved or changed in the open clamping position. For safety reasons, the serration for the base jaws is still engaged in this chuck piston position. The base jaws are unlocked manually.



#### ⚠ CAUTION

**There is a risk of crushing during manual loading due to the jaw stroke!**

We recommend automatic loading.

If manual loading is used, set up the jaw position so that there is no risk of injury when inserting the parts. The maximum opening gap must be less than 4 mm when the workpiece is in contact with one of the jaws.

For each jaw guidance, an eccentric bolt (item 4) with hexagon socket, which can be turned using the jaw change key (item 20), is arranged on the chuck perimeter. Turning the eccentric bolt moves the serration of the chuck axially out of the serration for the base jaw (item 22). In this position, the base jaws can be moved or changed radially inwards or outwards. It is not possible to pull out the jaw change key in this position; the chuck piston is locked.

**The jaw change key is locked so long as the chuck jaws have not been moved into the functional area! The functional area means that the base jaw is engaged by the serration of the chuck. The maximum position of the base jaws is marked on the chuck body.**

#### CAUTION

**The chuck piston (item 3) must not be moved as long as the jaw change key (item 20) is located in one of the eccentric bolt (item 4) for the chuck.**

**Risk of damage to the chuck.**

#### CAUTION

**The jaw change key must be inserted into the chuck as far as the stop before turning to the "change" position.**

Twisting too soon will lead to a malfunction of the jaw change mechanism.



**CAUTION**

Only adjust the chuck from the "change" to the "lock" position with the jaw correctly inserted. Do not apply excessive torque to the jaw change key. Risk of damage to the lathe chuck.

**5.2 Base jaw position**

A marking line between the jaw guidances is milled on the face side of the chuck. This marking line is the positioning aid for the base jaws or top jaws. The outermost base jaw or monoblock position is reached when the front face of the base jaw or the unsplit top jaw matches up with the marking line in the jaw change position (chuck open).

**CAUTION**

It is vital that the maximum jaw position is adhered to so that all teeth are engaged for the force transmission from the chuck to the base jaws or top jaws.

When the quick-change jaw is moved over the monitoring pin (Item 8) towards the clamping center, the monitoring pin must be manually pressed into the release position. Completely depress the monitoring pin with a suitable tool (A). Then move the top jaw radially outward from the chuck body (Item 1) while keeping the monitoring pin depressed (B).

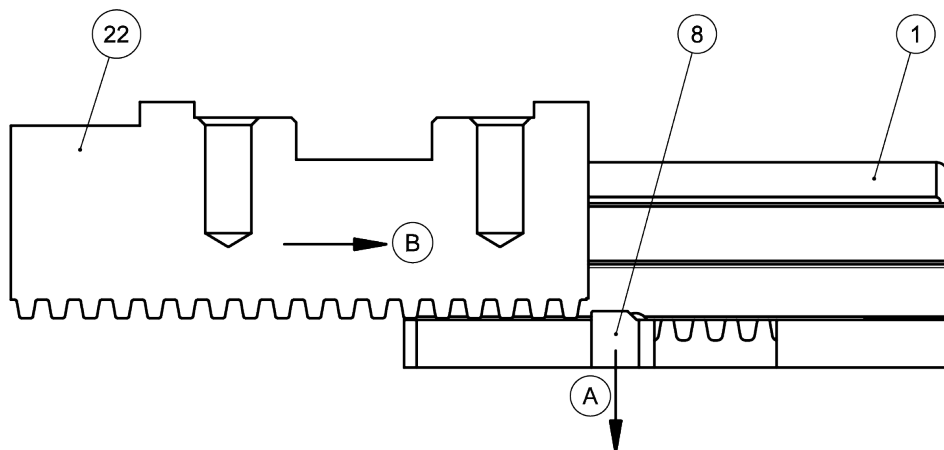

Item	Designation
1	Chuck body
8	Monitoring pin
22	Base jaw
A	Depress monitoring pin
B	Move base jaw

**CAUTION**

Excessive force (e.g. from hammer blows) will damage the clamping device.

### 5.3 Replacement or renewal of jaws

Chuck jaws for maximum clamping repeat accuracy must be turned or ground in the chuck under clamping pressure.

- When turning or grinding, ensure that the jaw turning ring or turning pin is clamped **by the top jaws** and not by the base jaws.
- Keep the base jaws and top jaws screwed in place for recurring work. Tighten the jaw mounting screws to the specified torque ▶ 4.1 [□ 26].

#### CAUTION

**Tighten the jaw mounting screws with a torque wrench. Faulty mounting of jaws can limit the function of the clamping device.**

#### CAUTION

**Make sure that the workpiece is clamped halfway up the base jaw stroke.**

**The workpiece must not be clamped at the end of the base jaw stroke. This can lead to the workpiece becoming loose.**

### 5.4 Functional testing

#### Functional test

After installation of the chuck, its function must be checked prior to start-up.

#### Two important points are:

- **Clamping Force!** The clamping force of the chuck must be achieved at max. operating force/pressure.
- **Stroke control!** The stroke of the clamping piston must allow a safety zone at the front and rear end position. The machine spindle may only be started when the clamping piston has passed through the safety zone. Only limit switches that meet the requirements for safety limit switches specified in DIN EN 60204-1 may be used.

When determining the necessary clamping force to machine a workpiece, take the centrifugal force acting on the chuck jaws into account (according to VDI 3106).

If the chuck jaws are changed, adjust the stroke control to the new situation.



#### ⚠ DANGER

**Risk of fatal injury to operating personnel if the top speed is exceeded, resulting in workpiece loss and parts flying off!**

- A reliable speed limiter must be installed in the machine tool or technical equipment and proof must be provided that the speed limiter is effective!

## 6 Maintenance

### 6.1 Lubrication

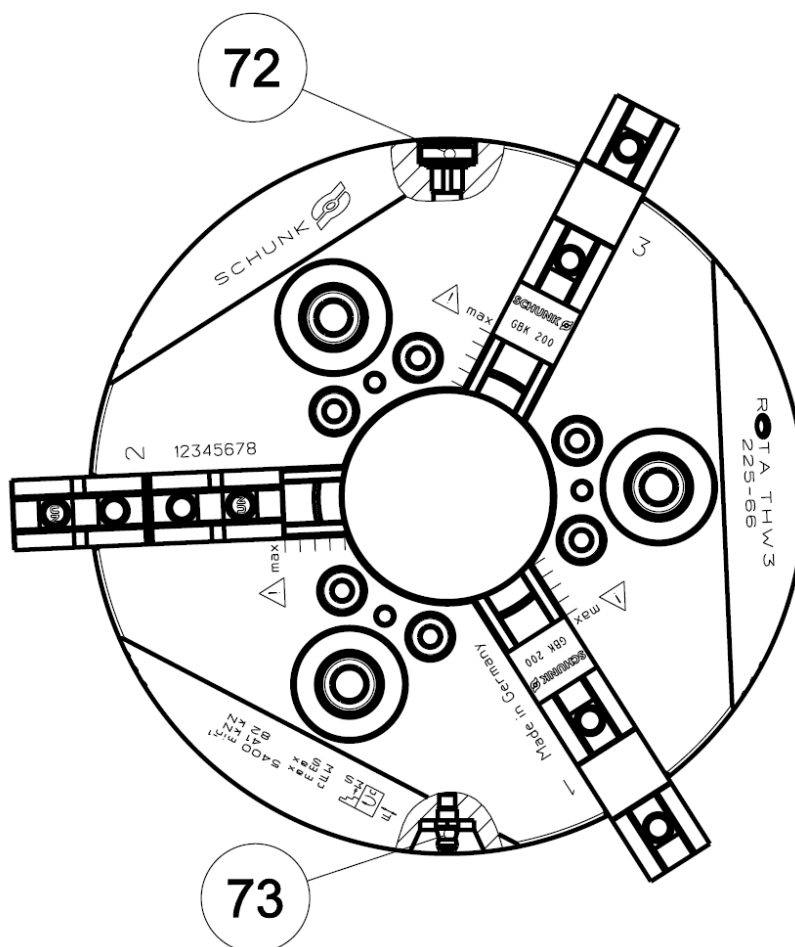

#### Greasing areas

To maintain the safe function and high quality of the lathe chuck, it must be regularly lubricated at the lubrication nipple (item 73) in the chuck body with LINOMAX plus.

1. Lubrication is only possible in the chuck position "open"; for this purpose, move the piston to its front end position.
2. Open the air bleed screw (item 72) and remove it.
3. Check the bore of the air bleed screw for possible blockage. If necessary, loosen the blockage with a suitable tool.
4. With a horizontally assembled chuck, position the air bleed screw so it is facing upwards.
5. Couple the mouth of the grease gun with the lubrication nipple.
6. Fill the chuck with grease until grease is visible at the air bleed screw.

7. Close and open the chuck completely several times (approx. 10 times) to distribute grease and displace air from the system.
8. Remove any excess grease on the air bleed screw outlet.
9. Screw in the air bleed screw to the stop.

For optimum grease distribution, the chuck piston must travel the entire clamping stroke several times after lubrication. After lubrication, check that the jaw change mechanism is working properly, ▶ 6.2 [ 36].



### **⚠ CAUTION**

**Allergic reactions if lubricating grease comes into contact with the skin.**

- Wear protective gloves.

### **CAUTION**

**Malfunctions after lubricating the chuck are due to air pockets in the system. The malfunction can be remedied by venting. To do this, repeat steps 2, 3, 7, 8, 9.**

#### **Operating conditions**

Depending on the operating conditions, the function and clamping force must be checked after a specific period of operation (see "Maintenance intervals" ▶ 6.2 [ 36]). Only perform the clamping force test with a calibrated clamping force tester (SCHUNK IFT).

## **6.2 Technical condition**

With the smallest possible actuating pressure (hydraulic cylinder), the base jaws should move evenly. This method only provides a limited indication and is not a substitute for measuring the clamping force. If the clamping force has dropped too much or if the base jaws and piston no longer move properly, the chuck has to be disassembled, cleaned and relubricated.

**Only use original SCHUNK spare parts when replacing damaged parts.**

#### **Checking correct functioning upon jaw change**

The mechanics of the jaw change notching/serrations must be checked at regular intervals; at the latest at the specified maintenance intervals. To do this, insert the jaw change key (item 20) into the eccentric bolt (item 4), and turn anti-clockwise to "change" position and remove base jaws from the chuck.

- Visual inspection of the serration for damage.
- In the "change" position, the serrations must be fully recessed.
- The monitoring pin (item 8) must have come out.
- It must not be possible to turn the jaw change key to the "lock" position without the base jaw.
- In the "change" position, the jaw change key cannot be removed.

### CAUTION

**Only adjust the chuck from the "change" to the "lock" position with the jaw correctly inserted. Do not apply excessive torque to the jaw change key. Risk of damage to the lathe chuck.**

## 6.3 Maintenance intervals

After one year, or after 250,000 clamping cycles, the chuck must be disassembled and completely cleaned.

Lubrication of the chuck ▶ 6.1 [ 35 ] must be carried out at the following intervals.

### Lubricating the greasing areas:

Interval	Demands
every 30 days or after 50,000 clamping cycles	normal / use of coolant
every 15 days or after 25,000 clamping cycles	high / use of coolant

## 6.4 Disassembling and assembling the chuck

The item numbers specified for the corresponding individual components relate to the chapter Drawings, ▶ 9 [ 45].

**The lathe chuck can only be disassembled once it has been removed.** ▶ 4 [ 26]

Before mounting the lathe chuck, the thrust jaws (item 2) and the mount (item 7) must be pre-assembled.

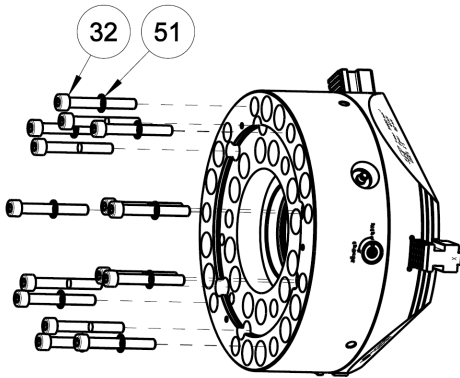

Remove screws (item 32) incl. screw seal (item 51) from the mount.

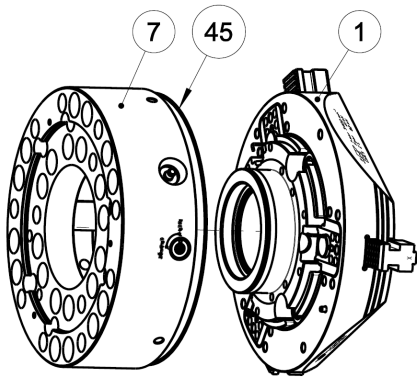

Remove the pre-assembled mount (item 7) and O-ring (item 45) from chuck body (item 1).

### Assembly:

Check the chuck body and mount are aligned using the cylindrical pin (item 71).

Do not turn the mount; otherwise the retrieval element (item 16) of the thrust jaw (item 2) may get damaged.

Insert the retrieval elements in the guide in the mount. Eccentric bolt (item 4) in the "lock" position.

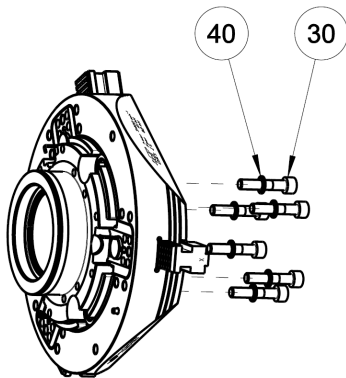

Remove screws (item 30) incl. the screw seal (item 40) of the chuck body.

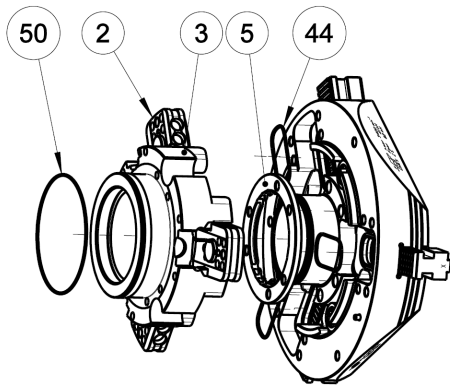

Remove the piston (item 3), pre-assembled thrust jaws (item 2) and guide ring (item 5) in the package, and then dismantle the individual components.

Remove the O-rings (item 50 / item 44) from the grooves.

**Assembly:**

Pre-position the wiper (item 10) flush with the chuck body (item 1) so that it can be joined with the thrust jaw.

Align the threaded holes of the guide ring with the bore holes of the chuck body.

Align base jaws (item 22) with the serration of the driver (item 6).

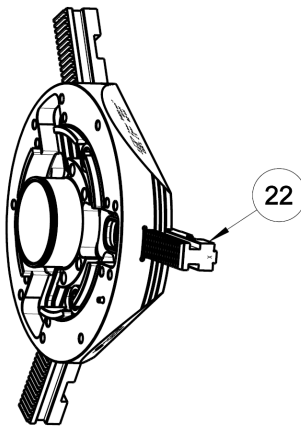

Remove the base jaws (item 22) from the guideway.

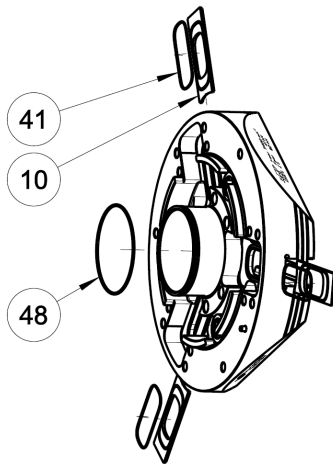

Remove the wiper (item 10) incl. the inserted O-ring (item 41) radially from the guide groove. Remove the O-ring (item 48) from the chuck body.

### Pre-assembly of thrust jaw

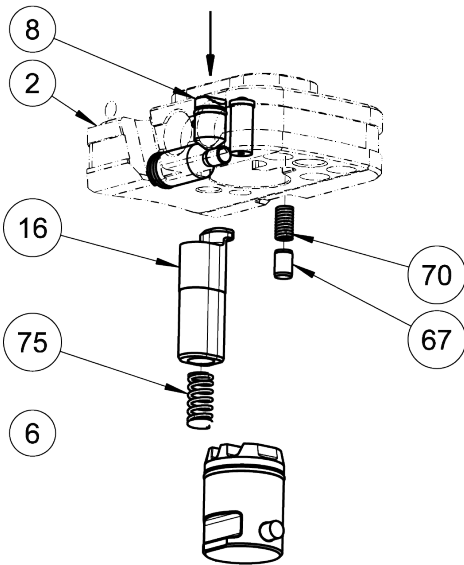

Push the monitoring pin (item 8) on the flat surface or the thrust jaw (item 2) to release the driver (item 6). Pull the driver downwards out of the thrust jaw. Remove the compression spring (item 70) and cylindrical pin (item 67) from the bore hole in the thrust jaw. Remove retrieval element (item 16) incl. compression spring (item 75) from the driver (item 6).

**Assembly:**

First insert the driver (item 6) into the top of the thrust jaw and only then press in the cylindrical pin (item 66). Ensure correct alignment of the retrieval element!

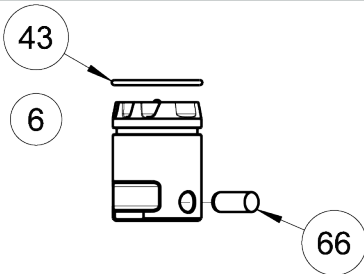

Remove O-ring (item 43) from the driver (item 6) and push out the cylindrical pin (item 66).

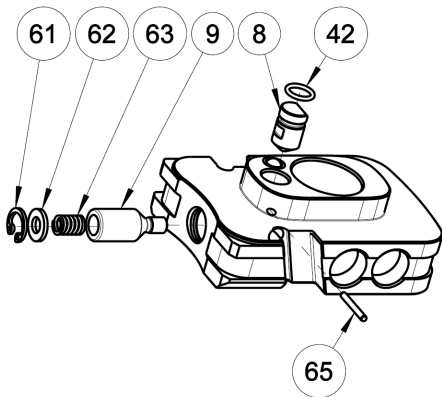

Remove the cylindrical pin (item 65) from the bore hole and push the monitoring pin (item 8) incl. O-ring (item 42) out of the thrust jaw.

Remove the locking pin (item 9), compression spring (item 63), washer (item 62) and safety ring (item 61) from the bore hole.



### Pre-assembly of mount

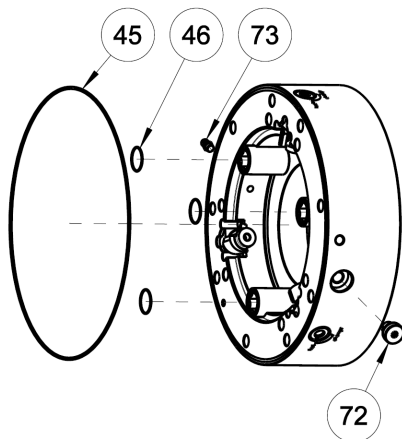

Remove O-rings (item 45 / item 46), unscrew the air bleed screw (item 72), unscrew the grease nipple (item 73).

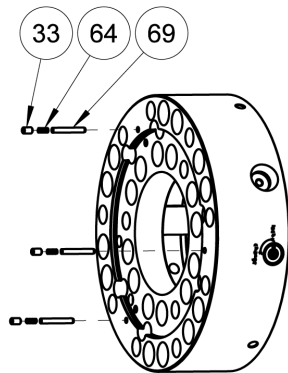

Release the lock (item 33), remove the compression spring (item 64) and the cylinder pin (item 69).

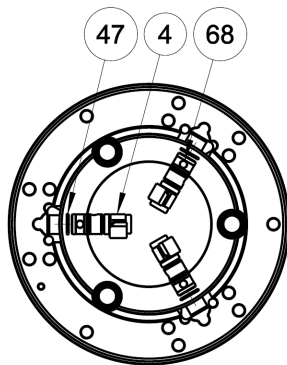

Remove the eccentric bolt (item 4) from the inside of the mount. Remove the ball (item 68) from the bore hole and the O-ring (item 47) from the groove of the eccentric bolt.

#### Assembly:

Push the eccentric bolt (item 4) completely into the bore hole and put in the "lock" position.

**Only use original SCHUNK spare parts when replacing damaged parts.**

The chuck is assembled in the same way, but in reverse order.

### CAUTION

**When assembling the base jaws, make sure that the numbers on the base jaws match the numbers on the jaw guides.**

## 7 Storage

When storing the product for a longer period of time, observe the following points:

- Clean the product and lubricate it lightly.
- Store the product in a suitable transport container.
- Only store the product in dry rooms.
- Protect the product from major temperature fluctuations.

**NOTE:** Before recommissioning, clean the product and all attachments, check for damage, functionality and leaks.

## 8 Part list

When ordering spare parts, it is essential to specify the type, size and, above all, the serial number of the chuck. **Seals, sealing elements, screw connections, springs, bearings, screws and wiper strips as well as parts that come into contact with the workpiece are not covered by the warranty.**

Item	Designation	Quantity	Note
1	Chuck body	1	
2	Thrust jaw	3	
3	Piston	1	
4	Eccentric bolt	3	
5	Guide ring	1	
6	Driver	3	
7	Mount	1	
8	Monitoring pin	3	
9	Locking pin	3	
10	Wiper	3	
14	Center sleeve	1	265 / 315 / 400 / 500 / 630
15	Ring	1	265 / 315 / 400 / 500 / 630
16	Retrieval element	3	
20	Jaw change key	1	
21	Eye bolt	1	225 / 265 / 315 / 400 / 500 / 630
22	Base jaw	3	
23	Assembly key	1	265 / 315 / 400 / 500 / 630
30	Screws	6	
31	Screws	3	
32	Screws	15	
33	Lock	3	
40	Screw seal	6	
41	O-ring	3	
42	O-ring	3	
43	O-ring	3	
44	O-ring	3	
45	O-ring	1	
46	O-ring	3	225 / 265 / 315 / 400
47	O-ring	3	
48	O-ring	1	
49	O-ring	1	265 / 315 / 400 / 500 / 630

<b>Item</b>	<b>Designation</b>	<b>Quantity</b>	<b>Note</b>
50	O-ring	1	
51	Screw seal	15	
52	O-ring	1	
53	Clamping cord	1	265 / 315 / 400 / 500 / 630
60	Pressure piece	3	
61	Safety ring	3	
62	Washer	3	
63	Compression spring	3	
64	Compression spring	3	
65	Cylindrical pin	3	
66	Cylindrical pin	3	
67	Cylindrical pin	3	
68	Ball	3	
69	Cylindrical pin	3	
70	Compression spring	3	
71	Cylindrical pin	1	
72	Air bleed screw	1	
73	Lubrication nipples	1	
74	Emblem	1	
75	Compression spring	3	

## 9 Drawing

### Full chuck

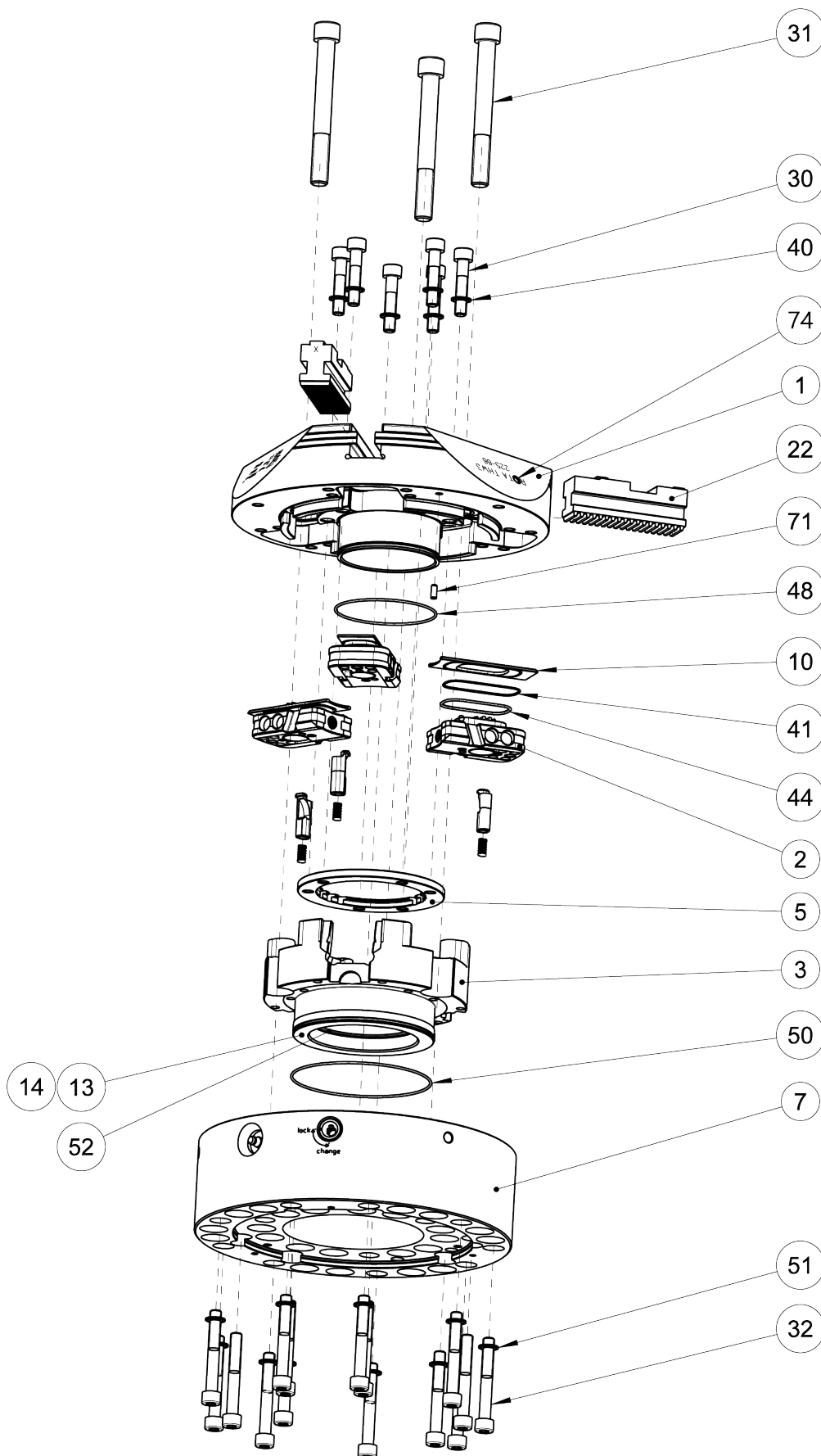

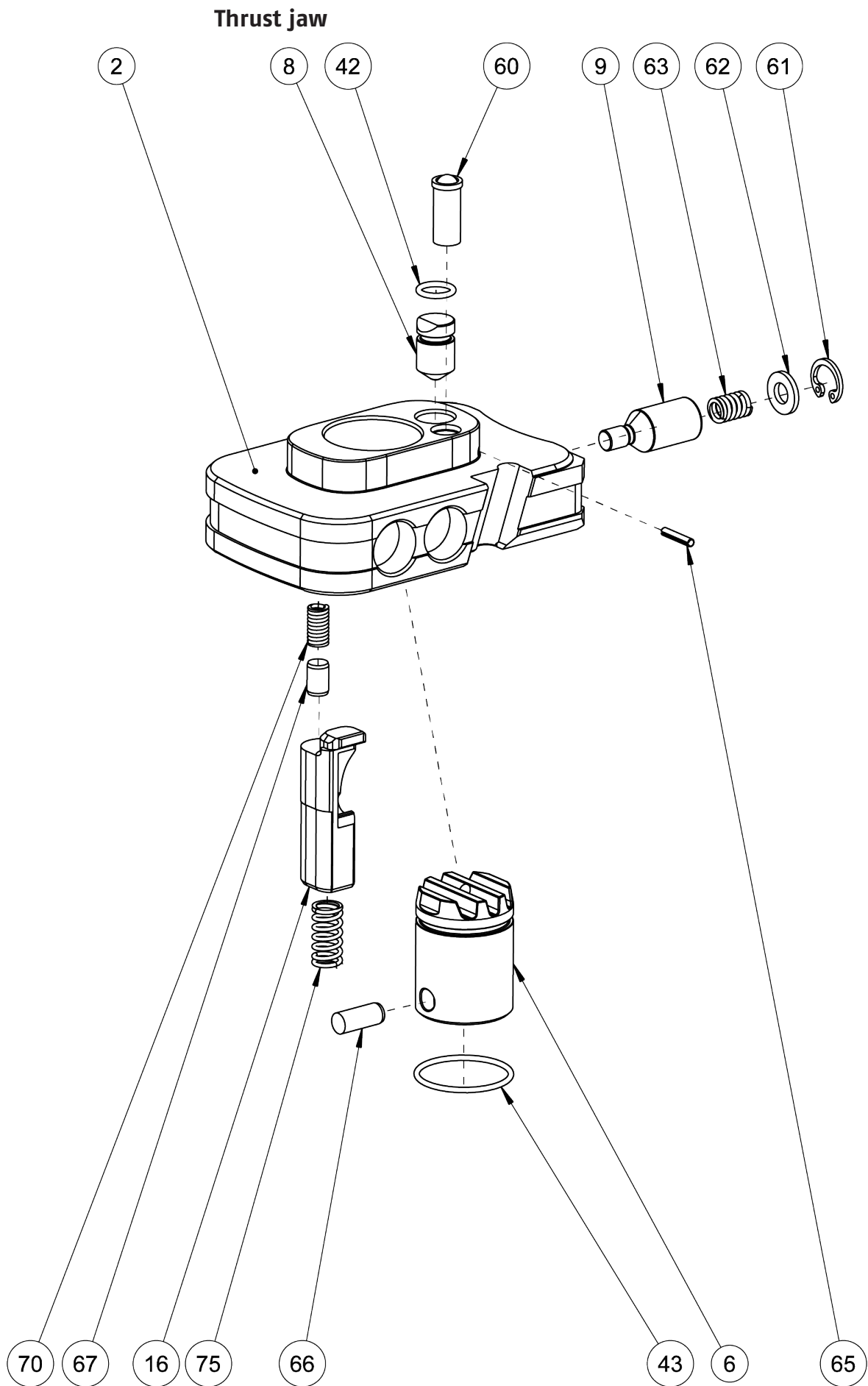

### Mount

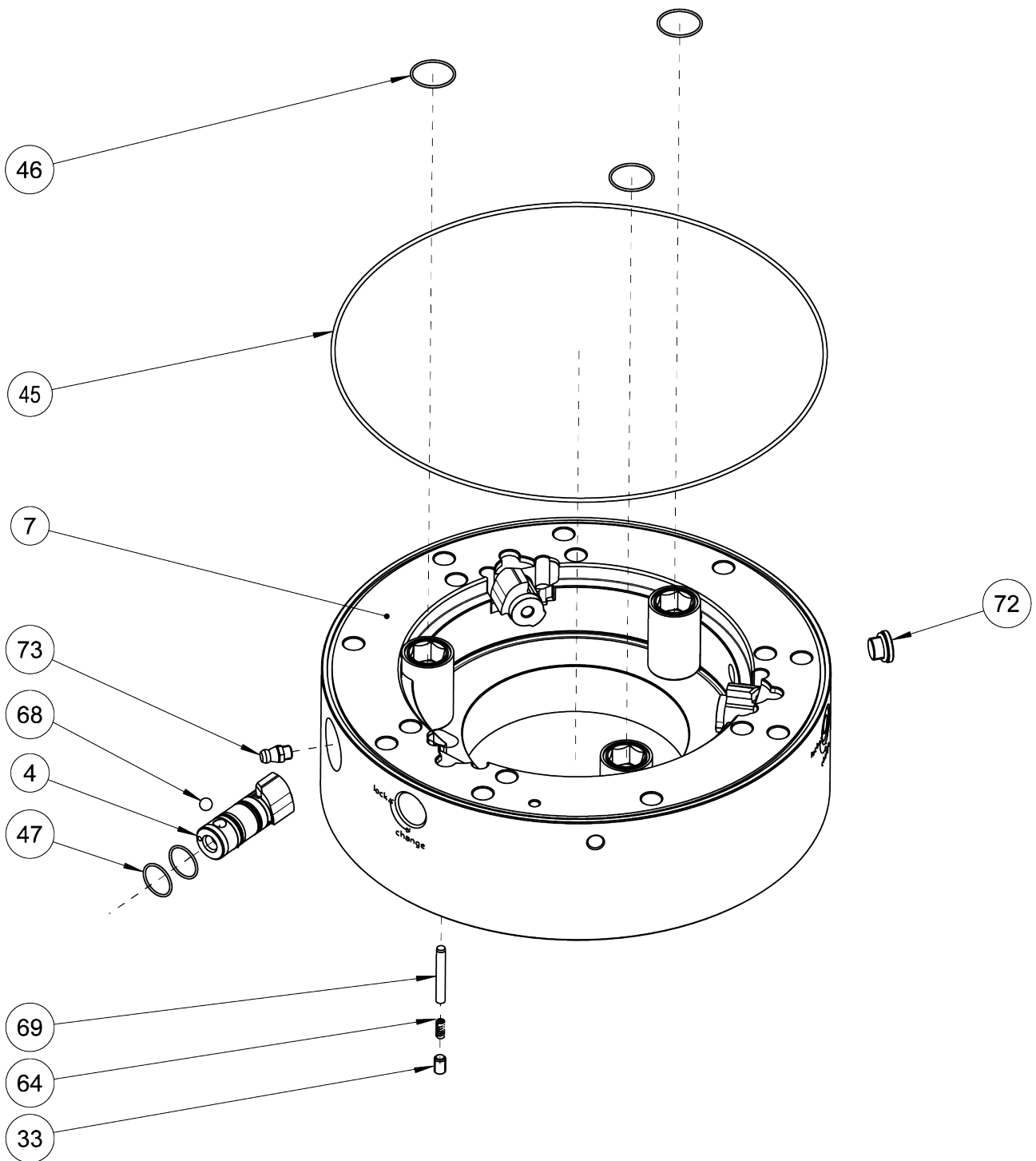

### Retaining ring center sleeve from size 265

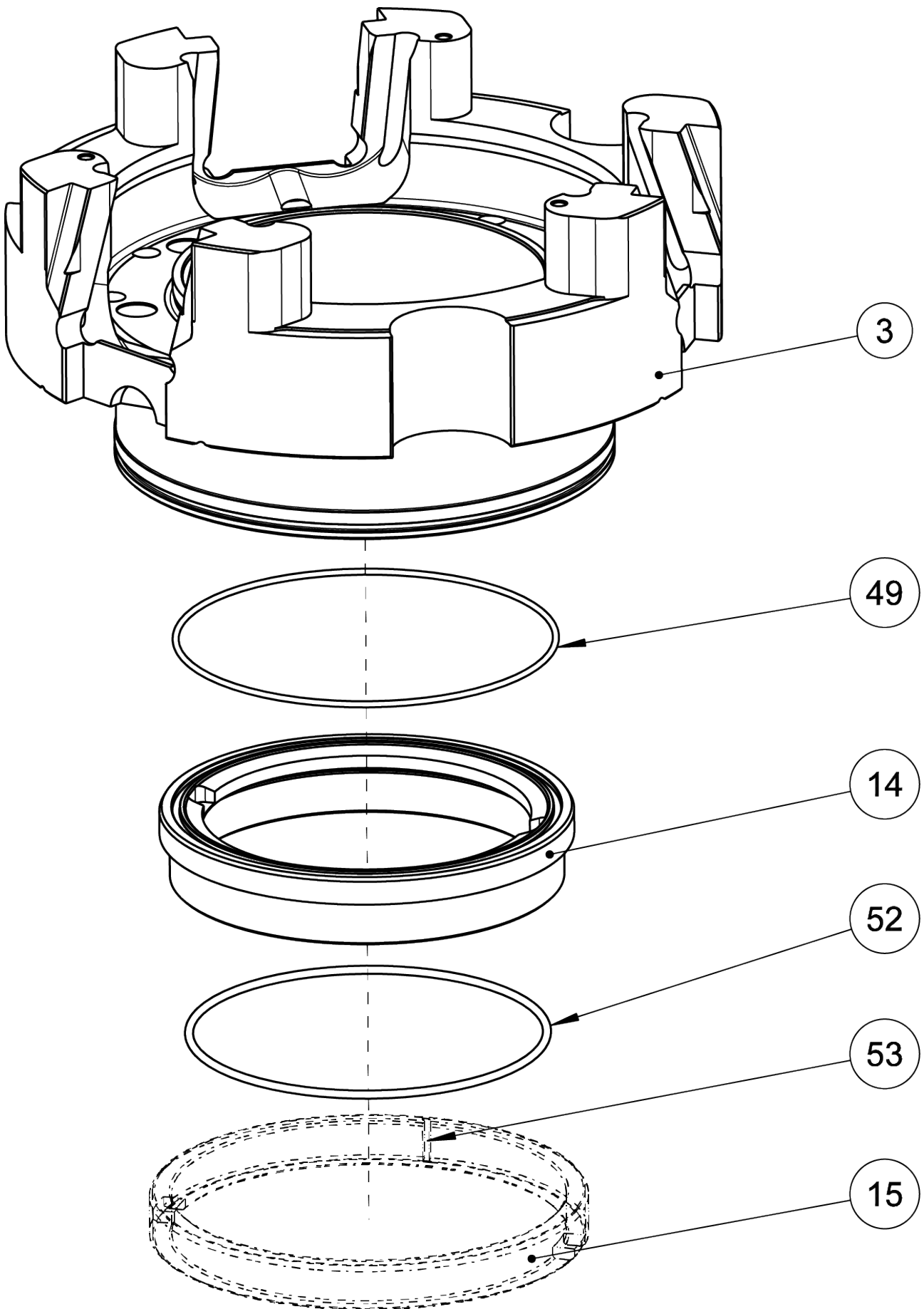



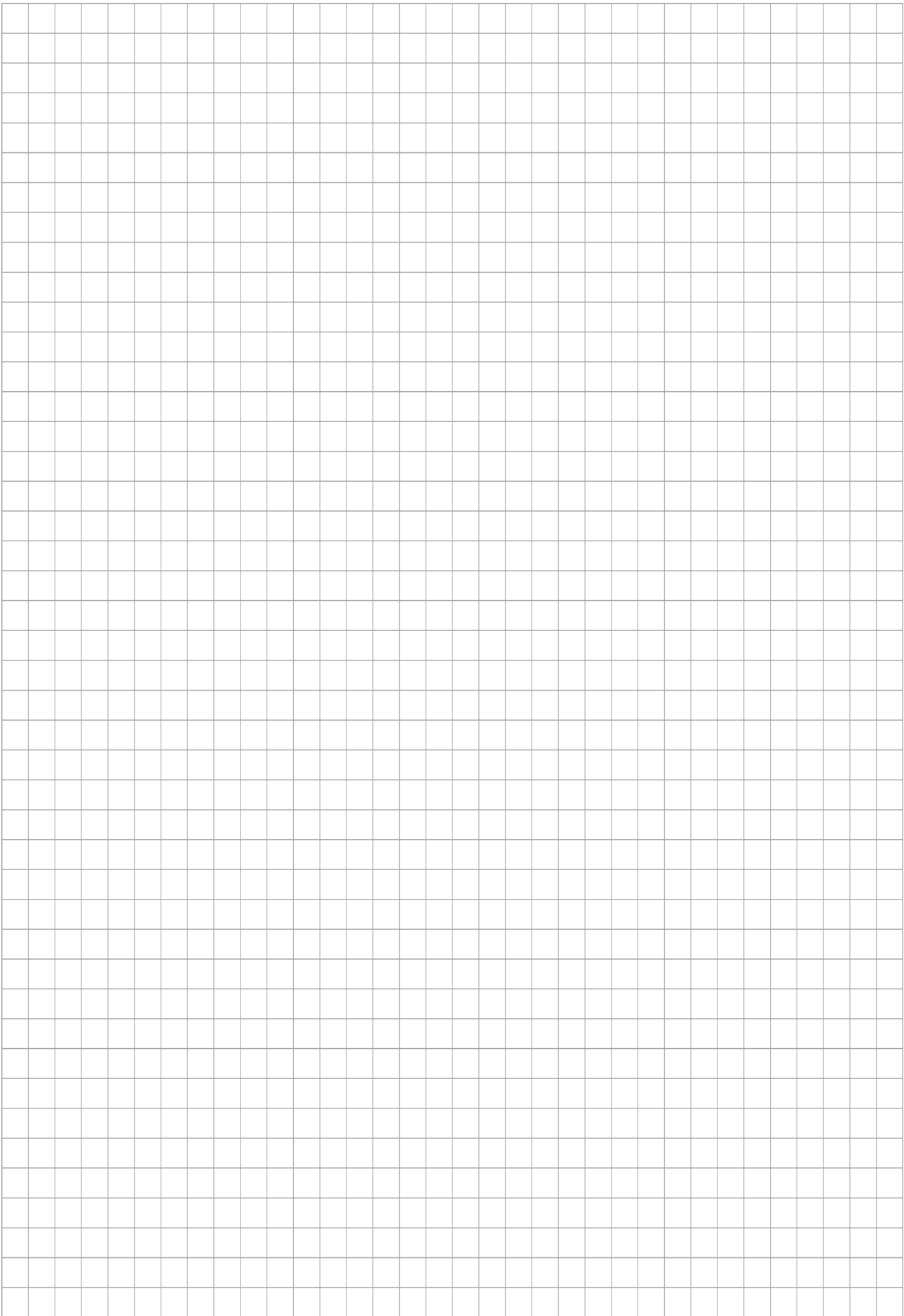

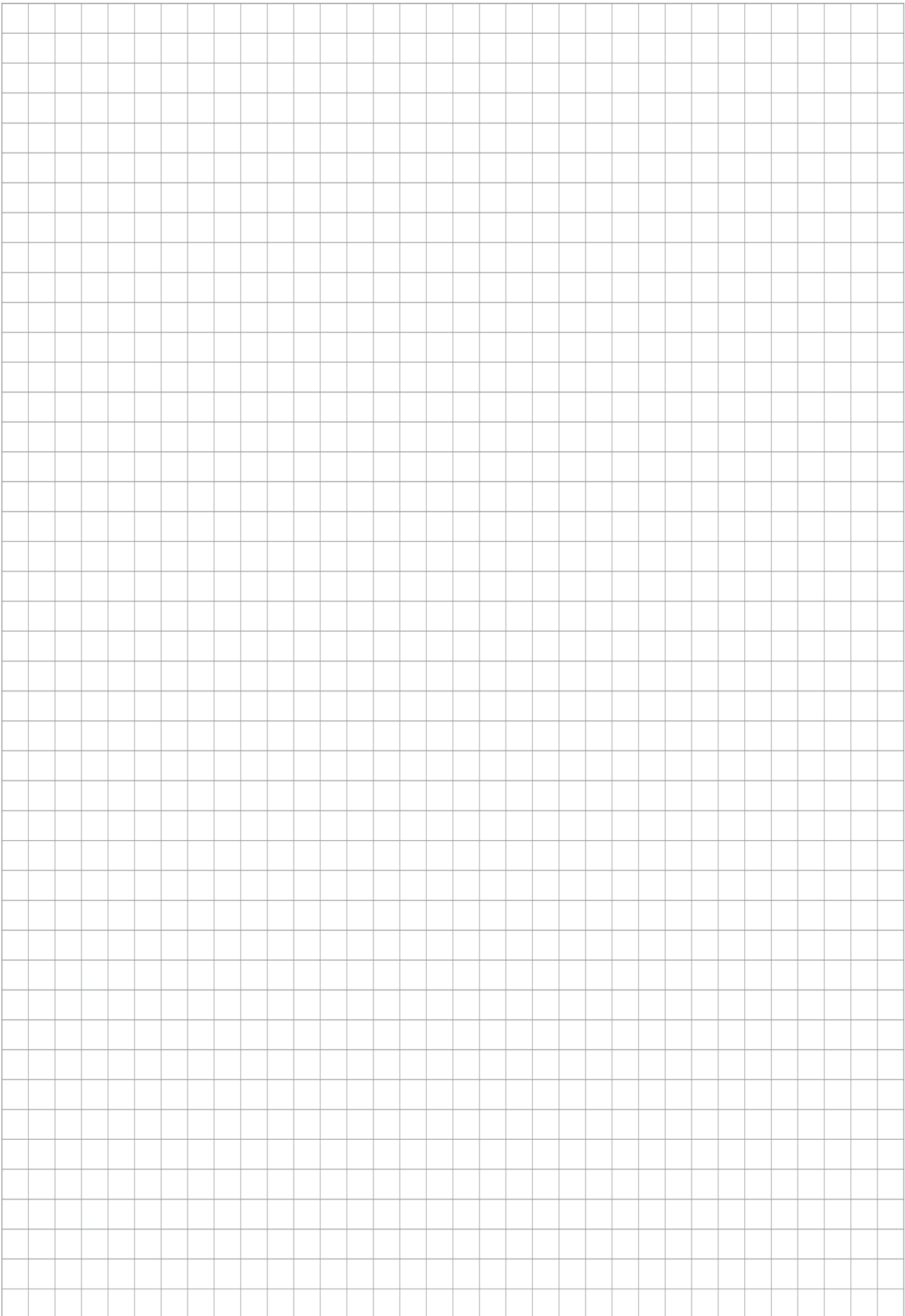

# Manufacturer certificate

**Manufacturer /** Heinz-Dieter SCHUNK GmbH & Co. Spanntechnik KG.  
**Distributor:** Lothringer Str. 23  
D-88512 Mengen

**Product:** Lathe chuck  
**Description:** ROTA  
**Type designation:** 2B, NCA, NCD, NCE, NC, NCF, NCK, NCO, NCR, NCS, NCX, TH, THW, HSH, HSA, DFF

Heinz-Dieter SCHUNK GmbH & Co. Spanntechnik KG certifies that the above-mentioned products, when used as intended and in compliance with the operating manual and the warnings on the product, are safe according to the national regulations and:

- a **risk assessment** has been carried out in accordance with ISO 12100:2010.
- an **operating manual** for the assembly instructions has been created in accordance with the contents of the Machinery Directive 2006/42/EC Annex I No. 1.7.4.2. and the contents of the provisions of Annex VI of the Machinery Directive 2006/42/EC.
- the relevant basic and proven safety principles of the Annexes of **ISO 13849-2:2012**, taking into account the requirements of the documentation have been observed for the component. The parameters, limitations, ambient conditions, characteristic values, etc. for correct operation are defined in the operating manual.
- an  $MTTF_D$  value of 150 years can be estimated for mechanical components using the informative procedure in Table C.1 of ISO 13849-1:2015.
- the **fault exclusion** against the fault "Unexpected release without pending release signal".
- the **fault exclusion** against the fault "Breakage during operation" in compliance with the parameters, limitations, ambient conditions, characteristic values and maintenance intervals, etc., specified in the operating manual.
- that internal bore diameters in the **pipe or control lines** are at least 2 mm for pneumatic clamping systems and at least 3 mm for hydraulic clamping systems

## Harmonized standards applied:

- **ISO 12100:2010** Safety of machinery - General principles for design - Risk assessment and risk reduction
- **EN 1550:1997+A1:2008** Machine-tools safety – Safety requirements for the design and construction of lathe chucks for the workpiece mount

## Other related technical standards and specifications:

- **ISO 702-1:2010-04** Machine tools – Connecting dimensions of spindle noses and lathe chucks – Part 1: front short-taper mount with screws
- **ISO 702-4:2010-04** Machine tools – Connecting dimensions of spindle noses and lathe chucks – Part 4: cylindrical mount
- **VDI 3106:2004-04:** Determination of permissible RPM of lathe chucks (jaw chucks)

Mengen, 02. Aug. 2023

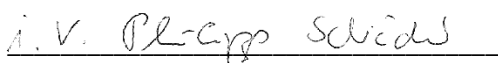

p.p. Philipp Schröder / Head of Development standard products

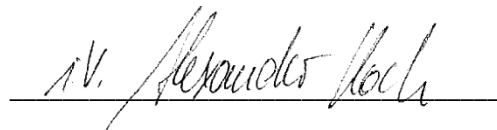

p.p. Alexander Koch / Head of Engineering Design special products



H.-D. SCHUNK GmbH & Co.  
Spanntechnik KG

Lothringer Str. 23  
D-88512 Mengen  
Tel. +49-7572-7614-0  
info@de.schunk.com  
schunk.com

Folgen Sie uns | *Follow us*



Wir drucken nachhaltig | *We print sustainable*