



Robot+PLUS

Compensation units AGM

Precise. Reliable. Modular.

Hand in hand for tomorrow

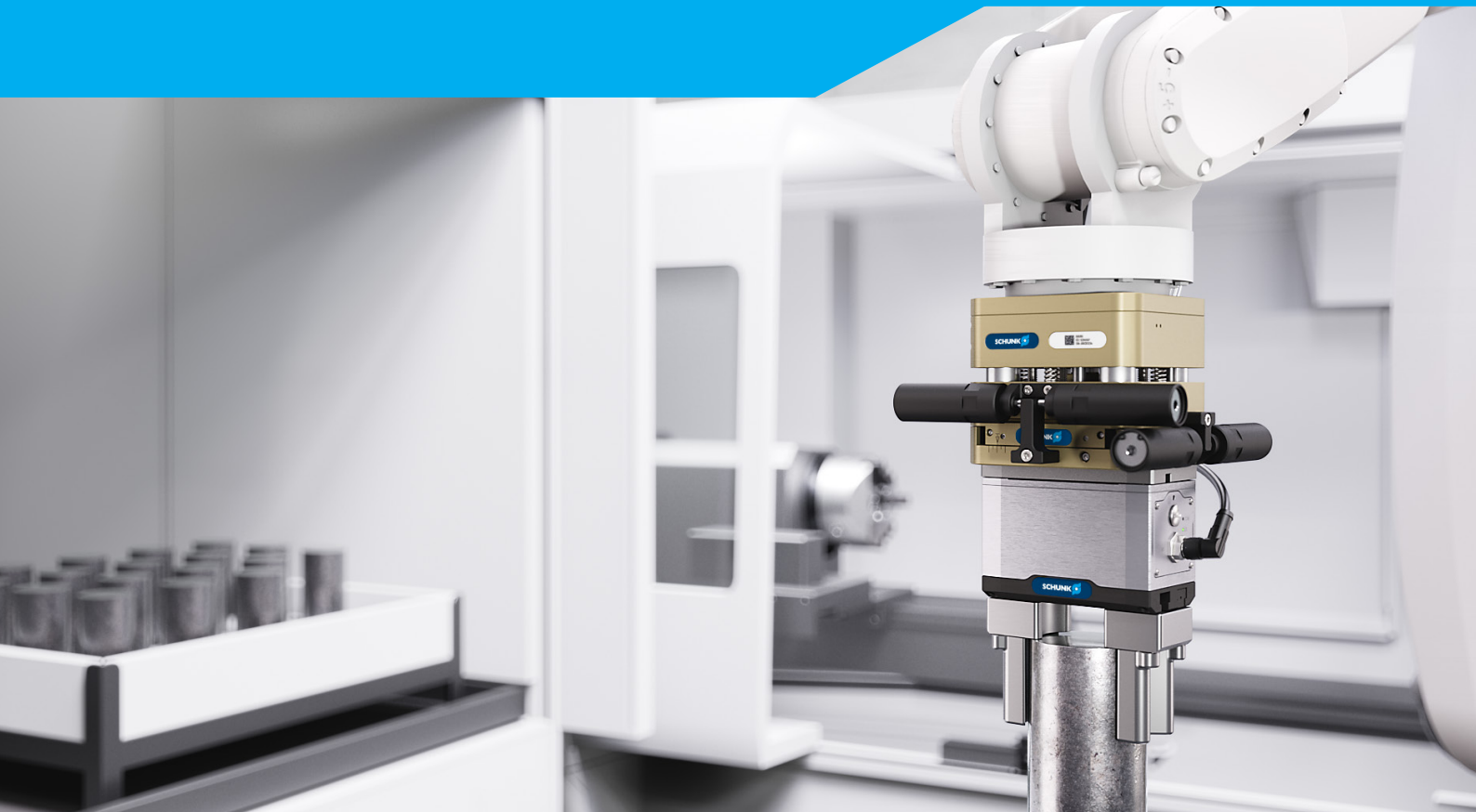

Compensation units AGM product family

The AGM product family plays a key role when it comes to compensating inaccuracies and tolerances in automated processes. In robotic applications, the product portfolio offers versatile solutions in the field of compensation to optimize process reliability and protect robots and components from wear.



Your benefits:

- + Always the right compensation behavior – in every axis and direction**
The broad AGM portfolio enables compensation in XY, Z, W and their combinations XYZ and WZ
- + Controlling gravity – regardless of mounting position and component weight**
Patented spring and air cartridges provide adjustable weight compensation and allow compensating from the neutral center position
- + Modular and combinable – precisely tailored to your application**
The modular design allows for combinable compensation paths – compactly integrated to meet various process requirements

When tolerances become a problem, AGM ensures reliable processes

The AGM product family is modular in design and consists of three series that can be flexibly combined with each other (XYZ-, WZ-direction). This allows SCHUNK to offer a customized solution for every customer-specific application.

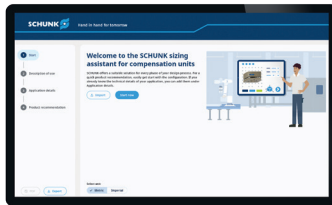
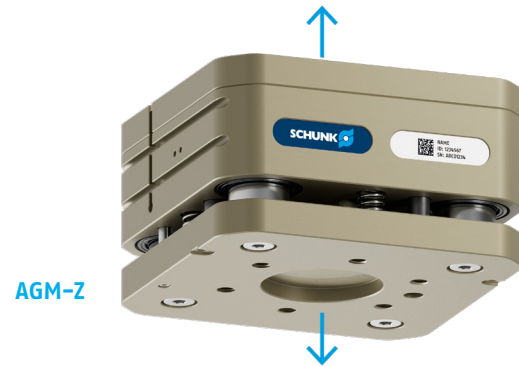
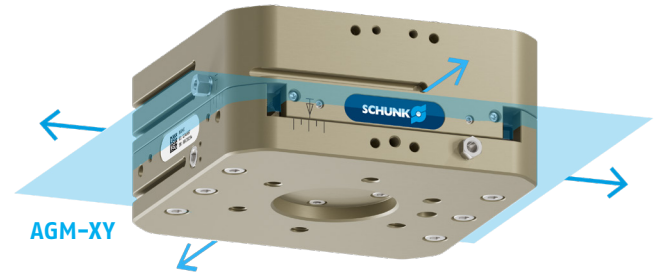

Find the right
product for your application – with our
sizing assistant!



schunk.com/compunit

Machine loading with AGM-XYZ



Machine loading

During the loading and unloading of machine tools, raw and finished parts are handled with a gripper or double gripper. Due to tolerances, forces may occur on the workpiece or the gripper. Such force situations can affect the process and lead to errors.

Benefit from the AGM – Your advantages:

- + **Increased process stability and efficiency** through the prevention of forces on the gripper and workpiece ensure optimized machine utilization
- + **Precise insertion of components** thanks to the appropriate compensation behavior in X-, Y- and Z-axes
- + **Weight compensation** with patented spring cartridges, the component is held in a defined position
- + **Optional sensor systems** capture the locking and unlocking of the AGM in the XY- and Z-directions without additional interfering contours

Weight compensation through patented spring and air cartridges

In applications where compensation in a horizontal or inclined position is required, the patented spring and air cartridges provide effective weight compensation. This innovative technology allows the compensation unit to stabilize against gravity and compensate in both the X- and Y-directions from the neutral central position. The weight compensation can be individually adjusted in both the X- and Y-directions to ensure optimal adaptation to different requirements.

Manual spring cartridges

This variant uses the principle of pure spring force and can be adjusted manually. Depending on the size, different force ranges are available to optimally adapt the weight compensation to the customized application.



Automated air cartridge

This variant combines the spring force with compressed air to allow adjustments during the process.



Insertion process with AGM-XY



Insertion processes

In automated insertion processes, especially with high production volumes, positioning or component tolerances pose significant challenges. Inaccuracies lead to downtime and costly scrap when parts are incorrectly inserted or damaged. The variability of components in size, shape, and weight – ranging from small, delicate circuit boards to large components such as engine blocks – requires flexible and precise handling technologies.

Benefit from the AGM – Your advantages:

- + **Compensation of inaccuracies and offset** in the X- and Y-axes allows reliable insertion of components
- + **The manually adjustable stroke** allows continuous limitation or locking of the compensation path, e.g., in Y-direction
- + **Suitable for delicate and fragile components** thanks to the smoothness of the guiding concept
- + **Meets requirements for shorter strokes**, lower compensation forces, and compact design, especially in height



Bin picking with AGM-W

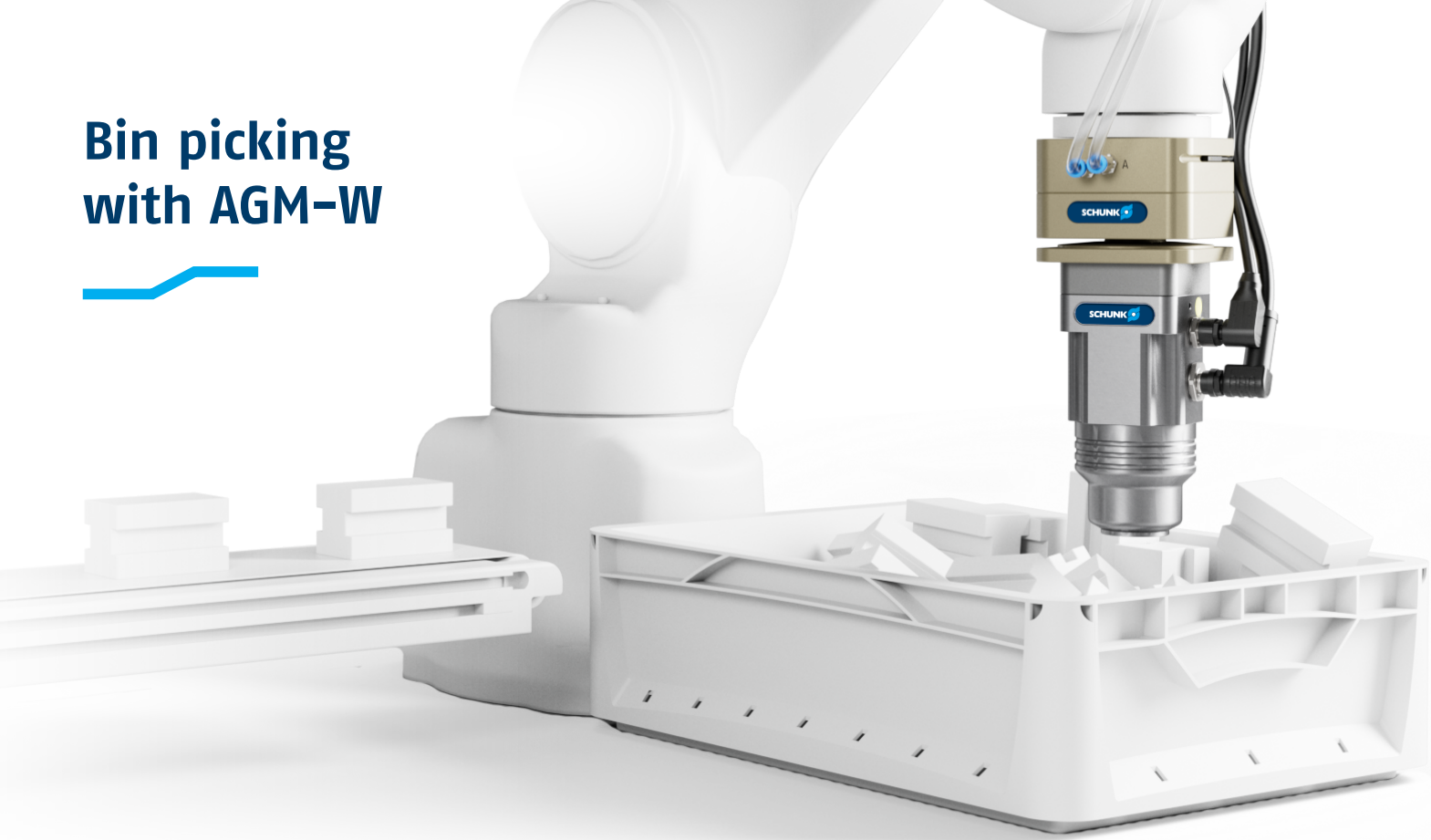

Bin picking

In bin picking applications, the undefined positions of the parts present a major challenge. The geometry of each part must be identified and securely grasped to enable collision-free removal. Since robots are unable to detect the parts on their own, costly vision systems are required. Additionally, the positions of the parts continuously change during removal, leading to misgrips and process delays. The desired cycle time is not achieved, the bin cannot be emptied fully automatically, which results in the need for manual rework.

Benefit from the AGM – Your advantages:

- + **Angular compensation** offsets the varying orientations of the components, allowing them to be gripped securely without getting caught
- + **Pneumatic locking and unlocking** supports highly dynamic processes with fast travel paths of robots or linear axis movements
- + **The pressure-dependent deflection torque** enables optimally controlled angular compensation in inclined spatial orientations
- + **Efficient part separation and complete emptying of the box** for fragile parts without damage

Customized to your requirements

Our AGM compensation units impress with their versatile range of applications. For specific requirements, our experienced engineering team develops customized concepts precisely tailored to your requirements.

Precision in E-Mobility

Designed for E-Mobility applications, this compensation unit allows compensation in the X-, Y- and rotational axes to avoid harmful forces on sensitive battery cells.

Interested?

In addition to the modular AGM compensation units, SCHUNK offers customized solutions for your individual requirements. Do not hesitate to get in touch with us.

Tel.: +49-7133-103-2990
automationsolution@de.schunk.com

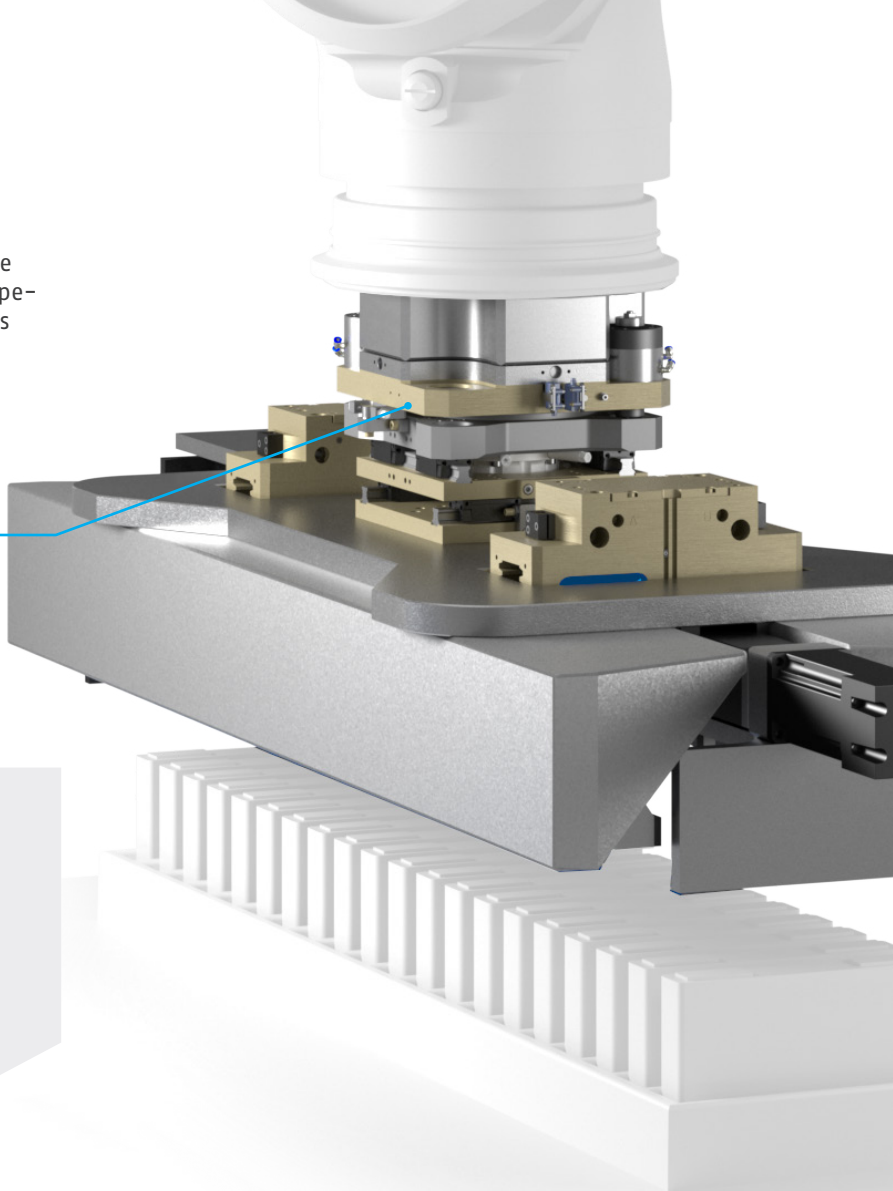

SCHUNK SE & Co. KG
Spanntechnik
Greiftechnik
Automatisierungstechnik

Bahnhofstr. 106 - 134
D-74348 Lauffen/Neckar
Tel. +49-7133-103-0
Fax +49-7133-103-2399
info@de.schunk.com
schunk.com

Follow us

