



Superior Clamping and Gripping



Product data sheet

Universal swivel unit SRM

SRM

Universal swivel unit

Robust. Fast. High Performance.

Universal rotary actuator SRM

Universally usable unit for pneumatic swivel and turning movements

Field of application

Can be used in either clean or dirty areas, or wherever pneumatic swiveling is required.



Advantages – Your benefits

Finely graded series with a steady increase in torque for multiple cases of application, the correct size as a standard product is available

Large center bore for feed-through of cables and hoses with the same unit height

Pre-adjusted shock absorber stroke for fast and easy commissioning

Swivel angle can be selected as either 90° or 180° complete flexibility in selecting the angle of rotation, application-specific angles possible on request

Selectable end position adjustability either small or large for flexible adjustability of the swivel angle

Optionally attachable fluid feed-through and electrical feed-through for permanently safe feed-through of gases, vacuum, and electrical sensor and actuator signals

Modular attachment to various options for individual adjustment to various cases of application

Choice of electronic magnetic sensors or inductive proximity sensors for absolute variability of position monitoring



Sizes
Quantity: 8



Weight
0.252 .. 11.14 kg



Torque
0.45 .. 23.7 Nm



Repeat accuracy
0.03 .. 0.07°



Angle of rotation
90 .. 180°

Functional description

When subjected to pressure, the two pneumatic pistons move their end faces in a straight line in their respective bores thus turning the pinion by means of the serrations on their sides.

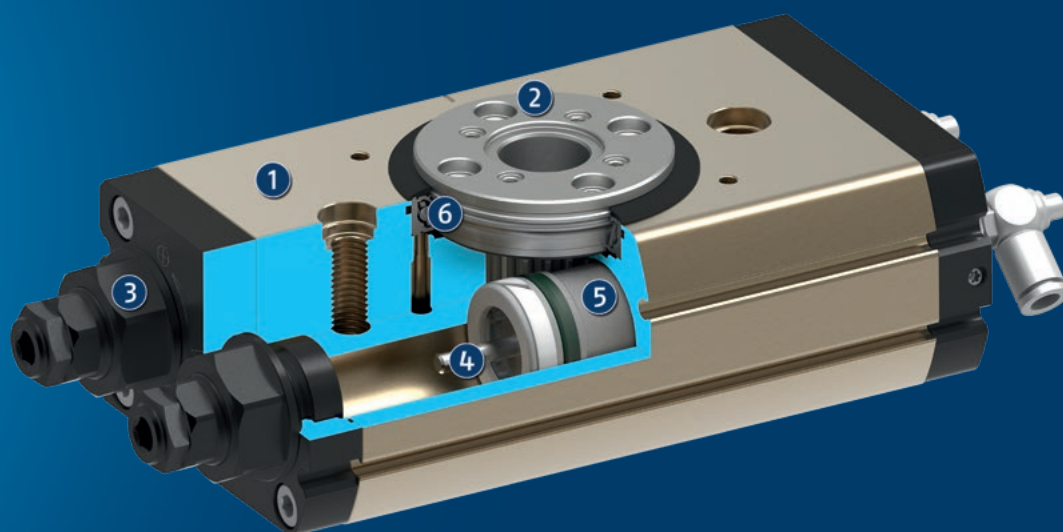

- | | |
|--|---|
| <p>① Housing
weight-optimized due to the use of hard-anodized aluminum alloy</p> <p>② Pinion
stable pinion for transforming the piston movement into a rotary movement</p> <p>③ Swivel angle adjustment
for quick, easy and intuitive end position adjustment</p> | <p>④ Damping
Hydraulic shock absorbers for high moments of inertia</p> <p>⑤ Drive
Pneumatic, powerful double piston drive</p> <p>⑥ Bearing
play-free, pre-loaded bearing</p> |
|--|---|

Detailed functional description

Bearing of the pinion

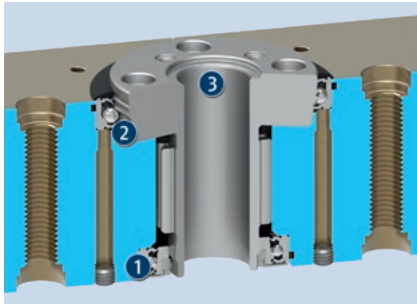

The pinion of the rotary module SRM is driven by two pistons, and is mounted at two points. The upper bearing is integrated in the pinion, whereby a minimum height of the entire unit is achieved. The lower bearing is pre-loaded free from play, whereby a very high accuracy and bearing stiffness is achieved. Both bearings are sealed to the outside with double-lip seals made of sturdy and durable FKM material.

- ❶ Pre-loaded bearing with double lip seal
- ❷ Integrated bearing with double lip seal
- ❸ Large center hole for feeding through cables and hoses

Adjustment of end position and shock absorber stroke



The two end positions and the respective shock absorber stroke can be manually adjusted laterally on the unit. Due to the factory presetting of the shock absorber stroke, its adaptation is not necessary for many applications. The markings on the cover show the influence of the direction of rotation on the adjustment of the swivel angle.

- ❶ Adjustment of the shock absorber stroke
- ❷ Adjustment of the end position

Version with external damping

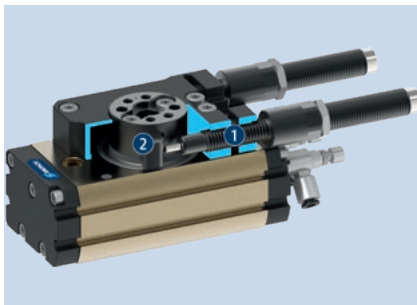

In the basic variant of the SRM, the movement of the drive pistons is damped by the shock absorbers in the piston chamber. In the variant with external damping, the shock absorbers are mounted on the output side of the unit. Here, the movement is directly damped on the rotary table. As a result, higher moments of inertia and a higher repeat accuracy can be realized. In addition, full torque is available in all positions.

- ❶ Hydraulic shock absorber
- ❷ Rotary table with mechanical stop

Variant with media feed-through



The SRM swivel unit can optionally be equipped with a media feed-through, which enables process-reliable feed-through of compressed air, gases, or vacuum. In case of sizes 10, 12, 14, and 16, the media feed-through can be optionally routed through the center bore, and in turn is covering it. In case of sizes SRM 20, 25, 32 and 40, the large center bore is completely intact, even if the option media feed-through is chosen.

- ❶ Connection for the set-up to be swiveled, equipped with fluid feed-throughs
- ❷ Connection fluid feed-throughs fixed part

Variant with electric rotary feed-through



The swivel unit SRM can optionally be equipped with an electrical rotary feed-through, thus ensuring operationally reliable feed-through of electrical signals. The electric rotary feed-through is equipped on both sides with standardized and color-coded M8 or M12 cable plugs. This makes it easy to identify the signal flow and simplify commissioning.

- ① Plug connector on the driving side, 4-pole, color coded
- ② Plug connector on the driven side, 3-pole, color coded
- ③ Plug connector on the driven side, 4-pole, color coded

Monitoring via electronic magnetic switches



There are two C-slots on each side of the SRM swivel unit, into which the SCHUNK electronic magnetic switches MMS can be inserted. This ensures flexible monitoring of the end positions, regardless of the installation position of the SRM.

- ① Monitoring with magnetic switch on the back of the swivel unit
- ② Monitoring with magnetic switch on the front of the swivel unit

Monitoring via inductive proximity sensors and adjustable control cam



To monitor the end positions of the swivel unit with inductive sensors, an additional set-up is mounted onto the rotary table. For flexible monitoring of individual swivel angles, a version with adjustable control cam is available. This allows up to three positions to be inductively monitored.

Monitoring via inductive proximity sensors and fixed control cam



For simple commissioning and maintenance of inductive monitoring, a version with a fixed control cam is also available. This is not adjustable and therefore only available for swivel angles of 180° or 90°. As a result, monitoring of up to three positions is possible.

Variant with pneumatic center position

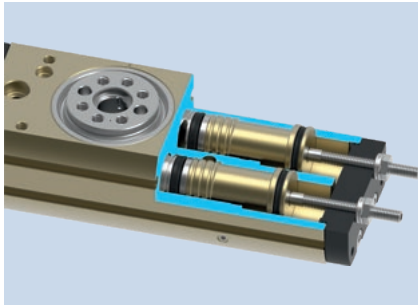

The SRM swivel unit can optionally be ordered with pneumatic center position. This makes it possible, to control a third position in addition to the two end positions.

Adjustment range of end positions and swivel angle

Versions with small end position adjustability

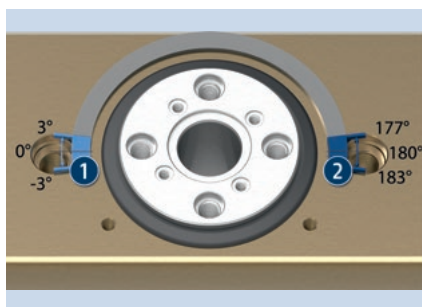

Slight end position adjustability for fine adjustment of both end positions ($\pm 3^\circ$) in case of swivel units with a swivel angle of 180°

- ❶ Adjustment range starting angle
- ❷ Adjustment range end angle

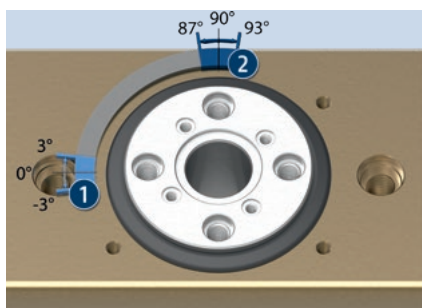

Slight end position adjustability for fine adjustment of both end positions ($\pm 3^\circ$) in case of swivel units with a swivel angle of 90°

- ❶ Adjustment range starting angle
- ❷ Adjustment range end angle

Version with large end position adjustability

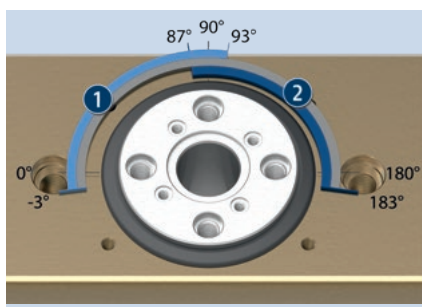

Large end position adjustability for variable adjustment of the swivel angle between 0° and 186° . Both end positions can each be limited by 90° ($\pm 3^\circ$).

- ❶ Adjustment range starting angle
- ❷ Adjustment range end angle

Ordering example

	SRM	25	-	H	-	180	-	3	-	M	-	4P	-	6E	-	SI
Description	SRM															
Size	10/12/14/16/20/25/32/40															
Type of damping method	H = hydraulic E = Elastomer (for sizes 10-14) X = external damping (for sizes 10-14) S = Speed damping (for size 12 and 14)															
Swivel angle	90°/180°															
End position adjustability	3 = ±3° 90 = +5°/-95° (for sizes 10 - 14) 90 = +3°/-93° (for sizes 16 - 40)															
Middle position	M = pneumatic center position															
Number of media feed-throughs	- = no 2P = 2 pneumatic feed-throughs (for size 10) 4P = 4 pneumatic feed-throughs (for sizes 12 - 40)															
Number of connectors for electric rotary feed-through	- = no 6E = 6 connectors per side (for sizes 16-32) 10E = 10 connectors per side (for size 40)															
Option for inductive proximity switches	- = no SI = with adjustable position (for sizes 16-40) SF = with fixed position (for sizes 16-40)															

General notes about the series

Standard conditions: The technical data shown refers to an environment of 20 °C and atmospheric pressure.

Housing material: Aluminum (extruded profile)

Actuation: pneumatic, with filtered compressed air as per ISO 8573-1:2010 [7:4:4].

Operating principle: Double piston rack and pinion principle

Scope of delivery: Swivel unit in the ordered variant, accessory kit (centering sleeves, O-rings for direction connection/detailed contents see operating manual) and safety information. Product-specific instructions can be downloaded at schunk.com/downloads-manuals.

Warranty: 24 months

Service life characteristics: on request

Repeat accuracy: is defined as a distribution of the end position for 100 consecutive cycles.

Pinion position: is always shown in the left end position. The pinion rotates from here to the right in clockwise direction. The arrow makes the direction of rotation clear.

Pinion screw connection diagram: When setting a swivel angle smaller than 90°, the left end stop must be completely turned in. This means that the left end position has a screw connection diagram on the pinion which is clockwise turned by 90° compared to the main view, which shows a swivel angle of 180°.

Customized angle of rotation: More swivel angles are available on request.

Torque in the end positions: Please note that the final angular degrees (approx. 2°) before the end position can only be approached using the force of a single drive piston. For this reason, double actuated modules only have about half the rated torque available in this area.

Travel to the pneumatic middle position: is carried out using only half of the nominal torque.

Swiveling time: is the rotation time of pinion/flange around the nominal rotation angle. Valve switching times, hose filling times, or PLC reaction times are not included and are to be considered when cycle times are calculated.

Application example

Swivel unit with electrical and pneumatic feed-through and double gripper for loading and unloading a machine tool

- ① Universal rotary actuator SRM
- ② Tolerance compensation unit TCU
- ③ Universal gripper PGN-plus-P
- ④ Inductive proximity switches IN
- ⑤ Magnetic switch MMS
- ⑥ Universal linear module Beta with toothed belt drive

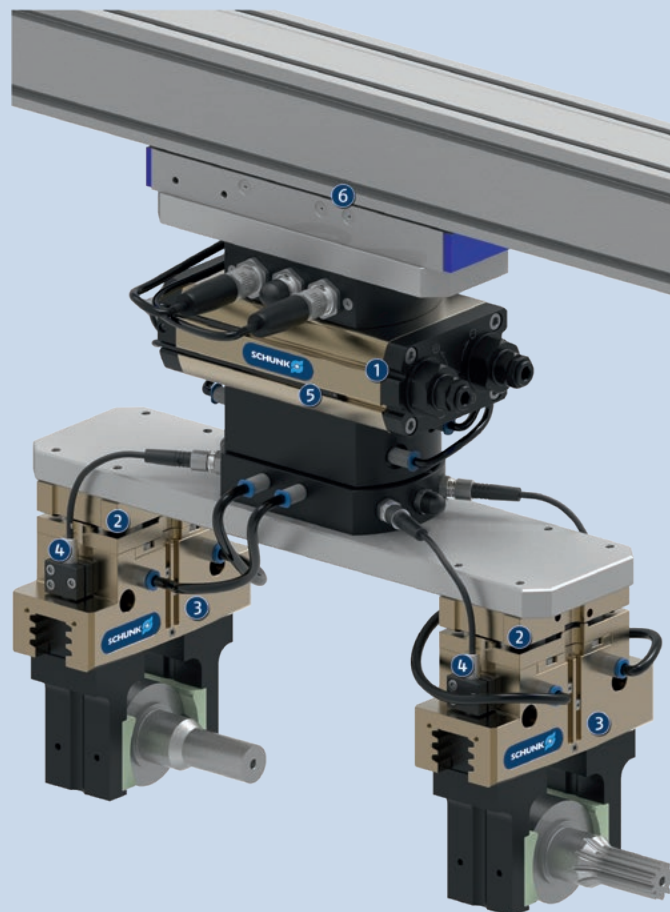

SCHUNK offers more ...

The following components make the product even more productive – the suitable addition for the highest functionality, flexibility, reliability, and controlled production.



Universal gripper



Gripper for small components



Linear module

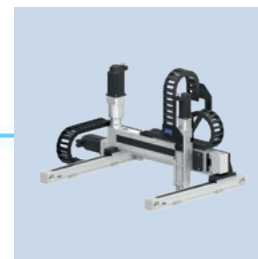

Room gantry



Fastened with screws



Inductive proximity switch



Magnetic switches



Pressure maintenance valve

① For more information on these products can be found on the following product pages or at [schunk.com](https://www.schunk.com).

Options and special information

Shock absorber variants: The basic version of the swivel unit SRM is equipped with hydraulic shock absorbers. Additional shock absorber variants are available: elastomer damping (E), external damping (X) and speed damping (S).

End position adjustability: The SRM is available in the two swivel angles 90° and 180° and the end positions can be fine adjusted. In this case, a fine adjustment of the end positions of $\pm 3^\circ$ is possible. For all deviating swivel angles, a large end position adjustability is optionally available. Thus, any angle of rotation between -3° and $+183^\circ$ can be realized.

Variant with media feed-through MDF: The optional media feed-through ensures process-reliable feeding through of compressed air, gases, or vacuum with four fluid channels.

Variant with electric rotary feed-through EDF: The optional electric rotary feed-through ensures process-reliable feed-through of electrical signals.

Variant with inductive monitoring: An additional attachment is required to monitor the SRM with inductive proximity switches. Here you can choose between fixed (SF) and adjustable (SI) switching position.

Please note that suitable emergency stop scenarios (e.g. controlled shut down) and restarting scenarios (e.g. pressure build-up valves, appropriate valve switching sequences) are needed for all pneumatic actuators.

Variant with pneumatic center position: The SRM swivel unit can optionally be ordered with pneumatic center position. This makes it possible, to control a third position in addition to the two end positions.

Food-grade lubrication: The product contains food-compliant lubricants as standard. The requirements of standard EN 1672-2:2020 are not fully met. The relevant NSF certificates are available at <https://info.nsf.org/USDA/Listings.asp> using the lubricant information in the operating manual. Components such as rolling bearings, linear guides, or shock absorbers are not provided with food-compliant lubricants.

SRM 10

Universal swivel unit

Dimensions and maximum loads

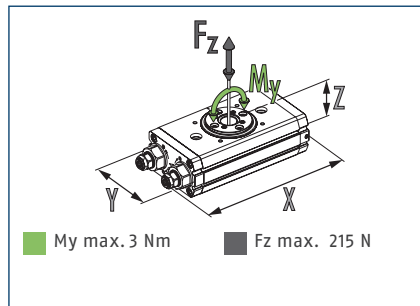

① The indicated moments and forces are static values, valid for the base unit, and may appear simultaneously. Throttling has to be done for ensuring that the rotary movement takes place without impact or bouncing. Otherwise the service life reduces.

Technical data SRM

Description		SRM 10-H-180-90	SRM 10-E-180-90	SRM 10-X-90-3	SRM 10-X-180-3
ID		1413281	1413282	1413286	1413285
End position damping		hydr. damper	Elastomer	External damper	External damper
Angle of rotation	[°]	180.0	180.0	90.0	180.0
End position adjustability	[°]	+5/-95	+5/-95	+3/-3	+3/-3
Torque	[Nm]	0.5	0.5	0.5	0.5
Number of intermediate positions		none	none	none	none
IP protection class		40	40	40	40
Weight	[kg]	0.266	0.252	0.33	0.33
Fluid consumption (2x nom. angle)	[cm ³]	7.2	7.2	4.2	7.2
Min./nom./max. operating pressure	[bar]	3/6/6.5	4.5/6/6.5	3/6/6.5	3/6/6.5
Diameter of connecting hose		3 x 1.8 x 0.6	3 x 1.8 x 0.6	3 x 1.8 x 0.6	3 x 1.8 x 0.6
Min./max. ambient temperature	[°C]	5/60	5/75	5/60	5/60
Cleanroom class ISO 14644-1:2015		5	5	5	5
Repeat accuracy	[°]	0.03	0.06	0.03	0.03
Diameter of center bore	[mm]	6	6	6	6
Max. permissible mass moment of inertia	[kgm ²]	0.0008	0.0009	0.0014	0.0014
Dimensions X x Y x Z	[mm]	125.6 x 36 x 25	114 x 36 x 25	120 x 45 x 35.5	120 x 45 x 35.5
Options					
with media feed-through (MDF)		SRM 10-H-180-90-2P	SRM 10-E-180-90-2P	SRM 10-X-90-3-2P	SRM 10-X-180-3-2P
ID		1413283	1413284	1413288	1413287

① The complete or supplementary technical data of all possible combinations can be found in the catalog below or at schunk.com.

Max. permissible inertia J*

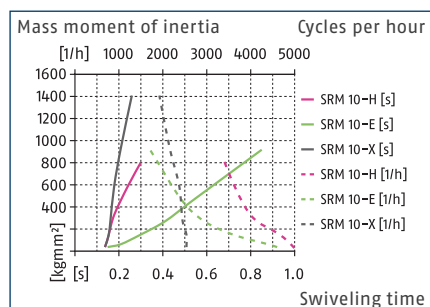

* *The diagrams are valid for basic units and for applications with a vertical swivel axis as well as for absolutely centric loads with a horizontal swivel axis and with an operating pressure of 6 bar. The swiveling times per throttling have to be observed, otherwise the life time may reduce. We will be happy to help you designing other applications. In addition, the SCHUNK Swiveling sizing assistant is available online.

Technical data SRM with center position

Description		SRM 10-H-180-90-M	SRM 10-E-180-90-M
ID		1482200	1482201
End position damping		hydr. damper	Elastomer
Angle of rotation	[°]	180.0	180.0
End position adjustability	[°]	+5/-95	+5/-95
Torque	[Nm]	0.5	0.5
Torque center position	[Nm]	0.3	0.3
Number of intermediate positions		1 x M (pneumatic)	1 x M (pneumatic)
Adjustability of middle position	[°]	+45/-45	+45/-45
IP protection class		40	40
Weight	[kg]	0.34	0.33
Fluid consumption (2x nom. angle)	[cm³]	8.8	8.8
Min./nom./max. operating pressure	[bar]	3/6/6.5	4.5/6/6.5
Diameter of connecting hose		3 x 1.8 x 0.6	3 x 1.8 x 0.6
Min./max. ambient temperature	[°C]	5/60	5/75
Cleanroom class ISO 14644-1:2015		5	5
Repeat accuracy	[°]	0.03	0.06
Diameter of center bore	[mm]	6	6
Max. permissible mass moment of inertia	[kgm²]	0.0008	0.0009
Dimensions X x Y x Z	[mm]	170 x 36 x 25	180 x 36 x 25
Options			
with media feed-through (MDF)		SRM 10-H-180-90-M-2P	SRM 10-E-180-90-M-2P
ID		1482202	1482203

① The complete or supplementary technical data of all possible combinations can be found in the catalog below or at schunk.com.

Main view of basic version with hydraulic damping

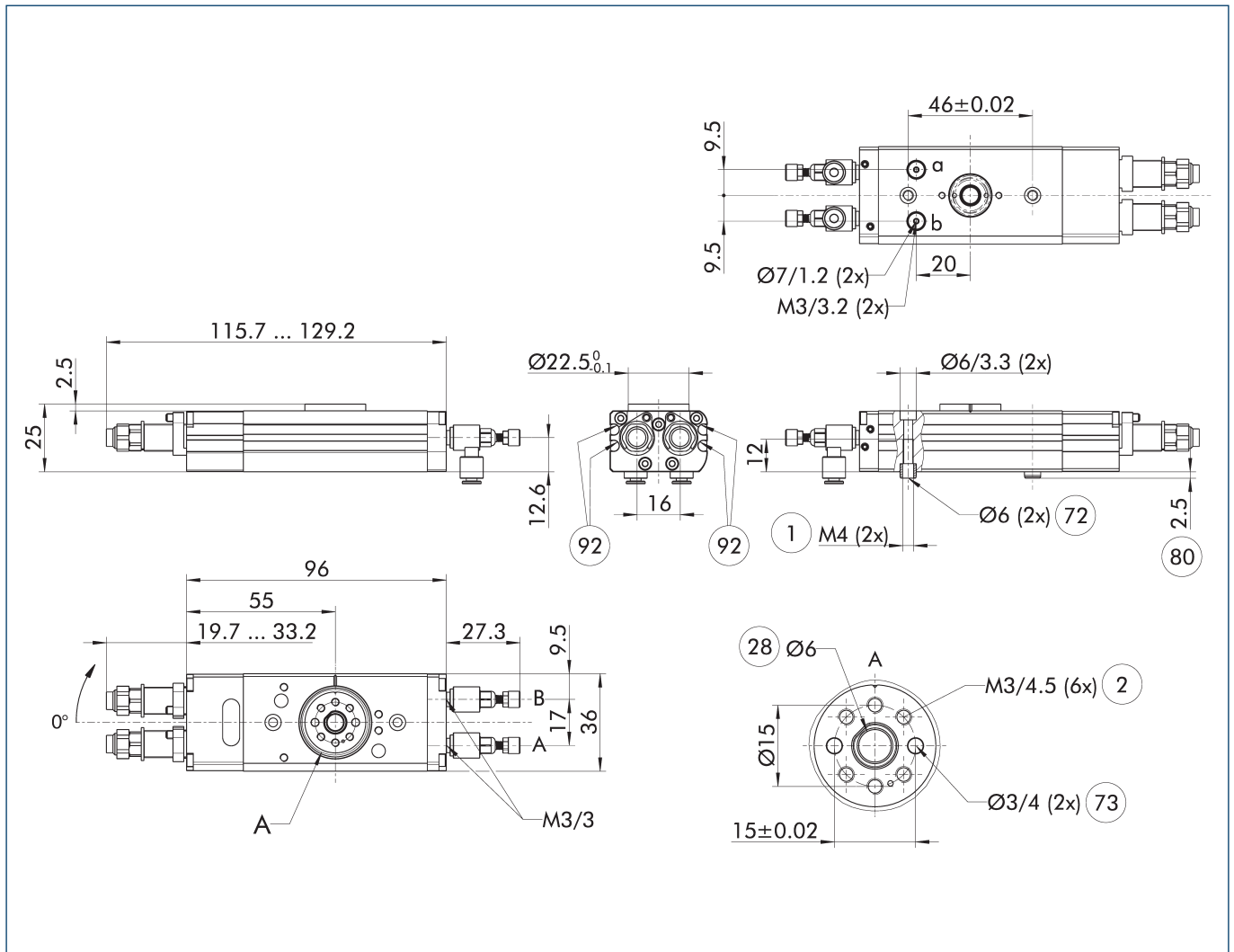

The drawing shows the unit in standard design, without considering any dimensions of the options described below.

① The SDV-P pressure maintenance valve can be used to maintain the position in the case of a loss of pressure (see "Accessories" catalog section).

A, a Main / direct connection, rotary actuator rotates clockwise

B, b Main / direct connection, rotary actuator rotates counterclockwise

① Connection swivel unit

② Attachment connection

②⑧ Through-hole

⑦② Fit for centering sleeves

⑦③ Fit for centering pins

⑧① Depth of the centering sleeve hole in the counter part

⑨② Sensor MMS 22..

Main view of basic version with elastomer damping

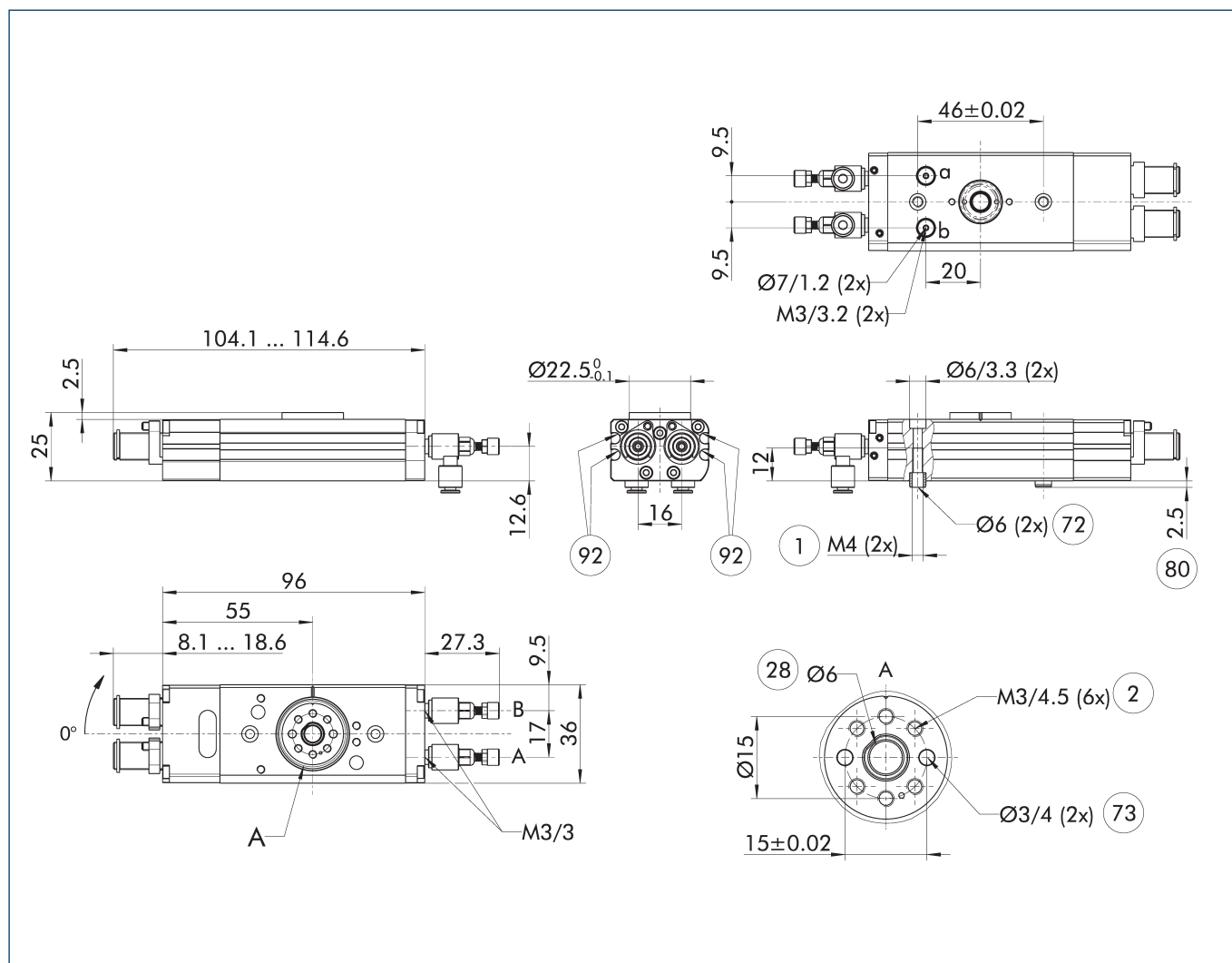

The drawing shows the unit in standard design, without considering any dimensions of the options described below.

① The SDV-P pressure maintenance valve can be used to maintain the position in the case of a loss of pressure (see "Accessories" catalog section).

- A, a Main / direct connection, rotary actuator rotates clockwise
- B, b Main / direct connection, rotary actuator rotates counterclockwise
- ① Connection swivel unit
- ② Attachment connection
- ②⑧ Through-hole
- ⑦② Fit for centering sleeves
- ⑦③ Fit for centering pins
- ⑧① Depth of the centering sleeve hole in the counter part
- ⑨② Sensor MMS 22..

Main view of basic version with external damping

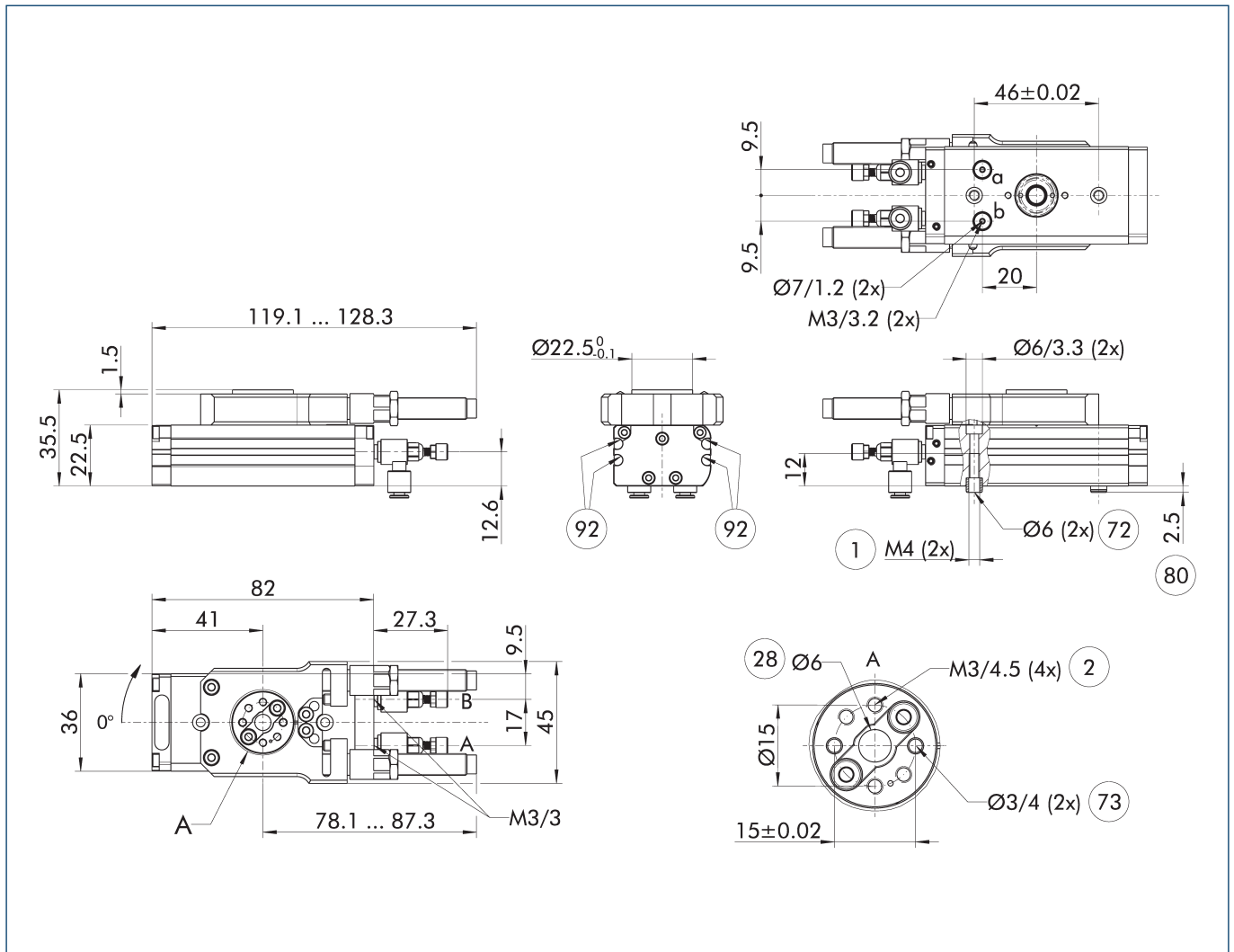

The drawing shows the unit in standard design, without considering any dimensions of the options described below.

① The SDV-P pressure maintenance valve can be used to maintain the position in the case of a loss of pressure (see "Accessories" catalog section).

A, a Main / direct connection, rotary actuator rotates clockwise

B, b Main / direct connection, rotary actuator rotates counterclockwise

① Connection swivel unit

② Attachment connection

②⑧ Through-hole

⑦② Fit for centering sleeves

⑦③ Fit for centering pins

⑧① Depth of the centering sleeve hole in the counter part

⑨② Sensor MMS 22..

Exemplary design

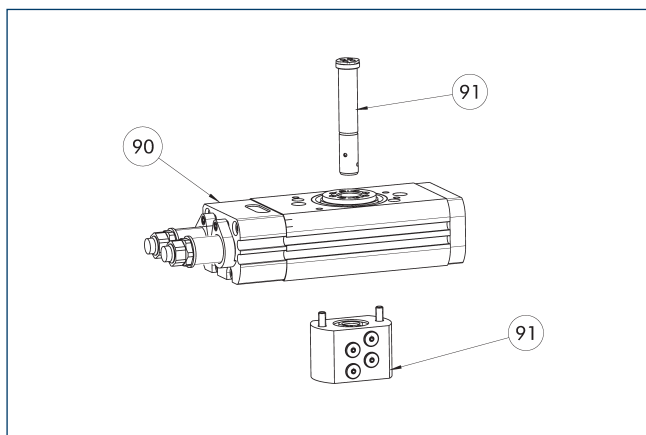

90 SRM basis

91 Option MDF

The drawing shows an example of the SRM with the maximum possible number of optional modules. The SRM can be ordered as a basic version without optional modules, with each option individually, or as a combination of several optional modules. The unit is supplied fully assembled. The options cannot be ordered separately. You can find a list of the available combinations including IDs in the technical data table.

Total height

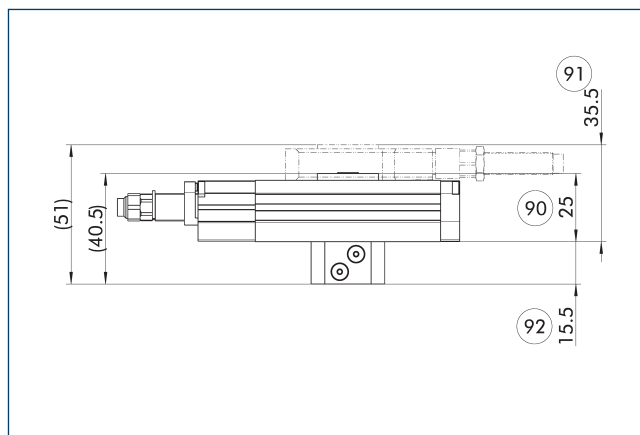

90 Total height SRM basic version (type of damping method H/E)

92 Additional dimension of the attached module, option MDF

91 Total height SRM basic (type of damping method X)

The drawing shows the maximum additional dimension. Depending on the selected optional modules, the total height is reduced accordingly.

Main view option of media feed-through MDF

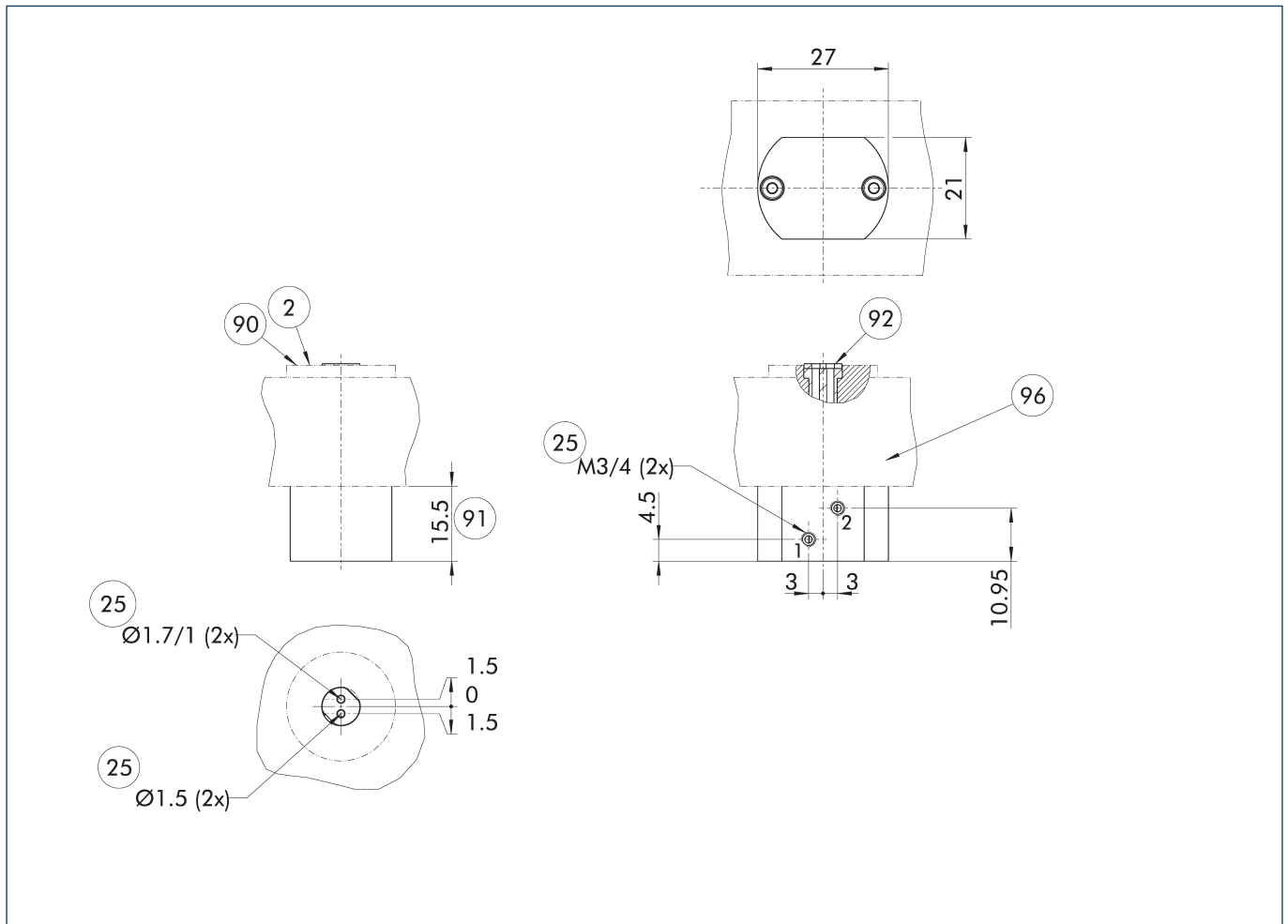

The drawing shows the option of media feed-through, without the base module or other options for the swivel unit.

- ② Attachment connection
- ②⑤ Fluid feed-through
- ⑨⑩ The screw connection diagram can be found in the drawing of the base unit.
- ⑨① Additional dimension of the attached module, option MDF
- ⑨② Seal
- ⑨⑥ SRM basis

Reduction of torque at 6 bar in the fluid feed-through	Weight of the module without base unit	No. of fluid feed-throughs	Min. pressure in the fluid feed-through	Max. pressure fluid feed-through	Max. volumetric flow of feed-through (at 6 bar)
[Nm]	[kg]		[bar]	[bar]	[l/min]
Option for media feed-through MDF					
- 0.05	0.025	2	-0.8	8	40

ⓘ This option cannot be ordered separately. It is a part of a configured version of the swivel unit. For the complete technical data of all the possible combination options, please configure the swivel unit at schunk.com. Please note that the above-mentioned data refer only to the option and not to the complete unit.

Hose-free direct connection M3

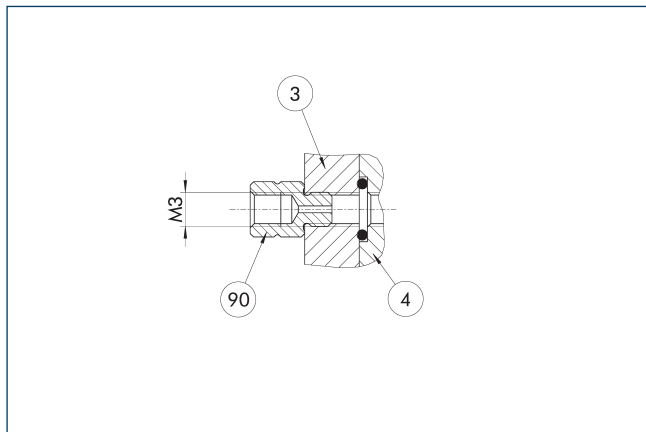

- ③ Adapter
- ④ Rotary unit
- ⑨⑩ Fixed throttle

The direct connection is used for compressed air supply without error-prone tubing. Instead, the pressure medium is fed through the bore-holes in the mounting plate. The required O-ring as well as the fixed throttle are enclosed to the product's accessory kit.

Adapter for SCHUNK gripper

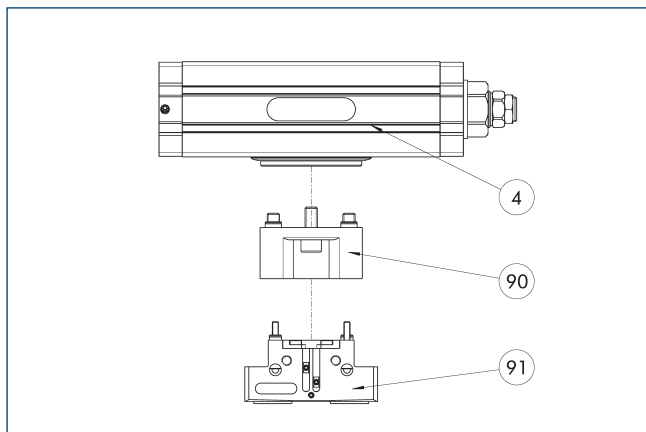

- ④ Rotary unit
- ⑨⑩ Adapter plate
- ⑨⑪ Grippers

Adapter plates are available for mounting many types of SCHUNK grippers. All combinations of swivel/gripping units, and associated adapter plates can be configured in the SCHUNK PARTCommunity and downloaded as a 3D model.

Pneumatic middle position (M)

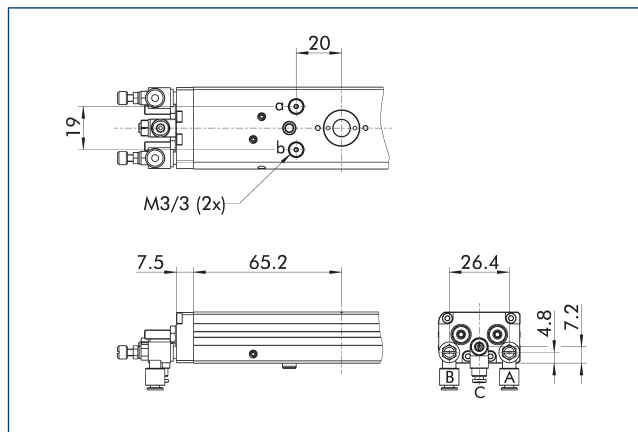

- A, a Main / direct connection, rotary actuator rotates clockwise
- B, b Main / direct connection, rotary actuator rotates counterclockwise
- C Main connection center position

The drawing shows the change in dimension of the "pneumatic center position (M)" option compared to the basic variant. Heavy attachments may swing before they reach the final position.

SRM 10

Universal swivel unit

Angle adapter WA

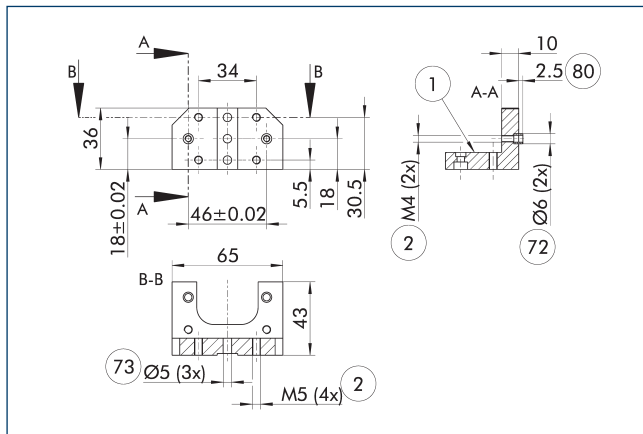

- ① Connection swivel unit
- ② Attachment connection
- ⑦③ Fit for centering pins
- ⑧① Depth of the centering sleeve hole in the counter part
- ⑦② Fit for centering sleeves

The angle adapter enables the swivel unit to be laterally connected with screws.

Description	ID
Adapter plate	
WA-SRM 10/12	1414971

Angle adapter WA

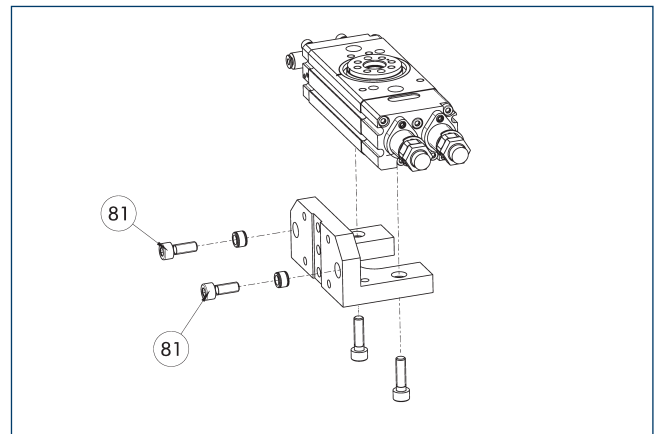

- ⑧① Not included in the scope of delivery

The angle adapter enables the swivel unit to be laterally connected with screws to the customer-specific superstructures or components from the modular assembly automation system.

Description	ID
Adapter plate	
WA-SRM 10/12	1414971

Electronic magnetic switch MMS

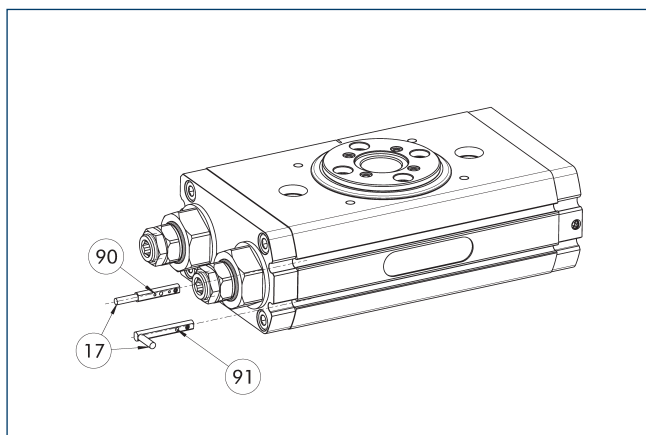

17 Cable outlet

91 Sensor MMS 22...-SA

90 Sensor MMS 22..

End position monitoring for mounting in the C-slot.

Description	ID	Often combined
Electronic magnetic switch		
MMS 22-S-M8-PNP	0301032	●
MMSK 22-S-PNP	0301034	
Electronic magnetic switches with lateral cable outlet		
MMS 22-S-M8-PNP-SA	0301042	●
MMSK 22-S-PNP-SA	0301044	
Connection cables		
KA BG08-L 3P-0300-PNP	0301622	●
KA BG08-L 3P-0500-PNP	0301623	
KA BW08-L 3P-0300-PNP	0301594	
KA BW08-L 3P-0500-PNP	0301502	
Clip for connector/socket		
CLI-M8	0301463	
Cable extension		
KV BW08-SG08 3P-0030-PNP	0301495	
KV BW08-SG08 3P-0100-PNP	0301496	
KV BW08-SG08 3P-0200-PNP	0301497	●
Sensor distributor		
V2-M8	0301775	●
V4-M8	0301746	
V8-M8	0301751	

- ① Two sensors are required per unit for monitoring two positions. On option, extension cables and sensor distributors are available. Additional product variants of the sensor, and further information and technical data can be found in the catalog chapter sensor system.

SRM 12

Universal swivel unit

Dimensions and maximum loads

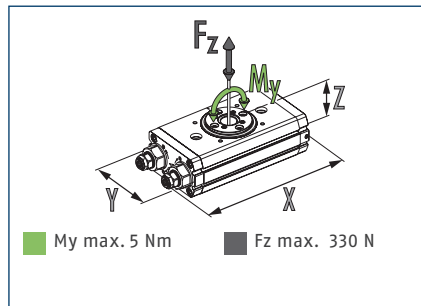

① The indicated moments and forces are static values, valid for the base unit, and may appear simultaneously. Throttling has to be done for ensuring that the rotary movement takes place without impact or bouncing. Otherwise the service life reduces.

Technical data SRM

Description		SRM 12-H-180-90	SRM 12-E-180-90	SRM 12-S-180-90	SRM 12-X-90-3	SRM 12-X-180-3
ID		1413289	1413300	1482204	1413304	1413303
End position damping		hydr. damper	Elastomer	hydr. damper	External damper	External damper
Angle of rotation	[°]	180.0	180.0	180.0	90.0	180.0
End position adjustability	[°]	+5/-95	+5/-95	+5/-95	+3/-3	+3/-3
Torque	[Nm]	0.8	0.8	0.8	0.8	0.8
Number of intermediate positions		none	none	none	none	none
IP protection class		40	40	40	40	40
Weight	[kg]	0.406	0.392	0.416	0.44	0.44
Fluid consumption (2x nom. angle)	[cm ³]	10.8	10.8	10.8	6.0	10.8
Min./nom./max. operating pressure	[bar]	3/6/6.5	4.5/6/6.5	3/6/6.5	3/6/6.5	3/6/6.5
Diameter of connecting hose		3 x 1.8 x 0.6	3 x 1.8 x 0.6	3 x 1.8 x 0.6	3 x 1.8 x 0.6	3 x 1.8 x 0.6
Min./max. ambient temperature	[°C]	5/60	5/75	5/60	5/60	5/60
Cleanroom class ISO 14644-1:2015		5	5	5	5	5
Repeat accuracy	[°]	0.03	0.06	0.04	0.03	0.03
Diameter of center bore	[mm]	8	8	8	8	8
Max. permissible mass moment of inertia	[kgm ²]	0.005	0.0036	0.0025	0.0072	0.0072
Dimensions X x Y x Z	[mm]	130.9 x 41 x 30.5	121.5 x 41 x 30.5	151 x 41 x 31	124.1 x 45 x 41.5	124.1 x 45 x 41.5
Options						
with media feed-through (MDF)		SRM 12-H-180-90-4P	SRM 12-E-180-90-4P	SRM 12-S-180-90-4P	SRM 12-X-90-3-4P	SRM 12-X-180-3-4P
ID		1413301	1413302	1482205	1413306	1413305

① The complete or supplementary technical data of all possible combinations can be found in the catalog below or at schunk.com.

Max. permissible inertia J*

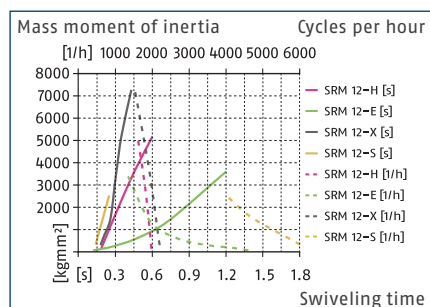

Max. permissible inertia J*

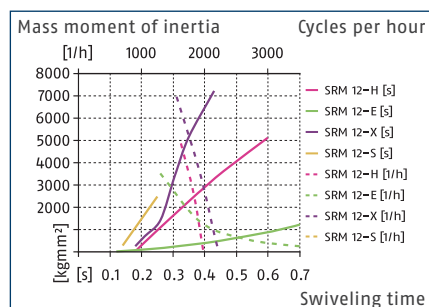

* *The diagrams are valid for basic units and for applications with a vertical swivel axis as well as for absolutely centric loads with a horizontal swivel axis and with an operating pressure of 6 bar. The swiveling times per throttling have to be observed, otherwise the life time may reduce. We will be happy to help you designing other applications. In addition, the SCHUNK Swiveling sizing assistant is available online.

Technical data SRM with center position

Description		SRM 12-H-180-90-M	SRM 12-E-180-90-M
ID		1482206	1482207
End position damping		hydr. damper	Elastomer
Angle of rotation	[°]	180.0	180.0
End position adjustability	[°]	+5/-95	+5/-95
Torque	[Nm]	0.8	0.8
Torque center position	[Nm]	0.5	0.5
Number of intermediate positions		1 x M (pneumatic)	1 x M (pneumatic)
Adjustability of middle position	[°]	+45/-45	+45/-45
IP protection class		40	40
Weight	[kg]	0.51	0.50
Fluid consumption (2x nom. angle)	[cm³]	15.0	15.0
Min./nom./max. operating pressure	[bar]	3/6/6.5	4.5/6/6.5
Diameter of connecting hose		3 x 1.8 x 0.6	3 x 1.8 x 0.6
Min./max. ambient temperature	[°C]	5/60	5/75
Cleanroom class ISO 14644-1:2015		5	5
Repeat accuracy	[°]	0.03	0.06
Diameter of center bore	[mm]	8	8
Max. permissible mass moment of inertia	[kgm²]	0.003	0.0036
Dimensions X x Y x Z	[mm]	180 x 41 x 30.5	170 x 41 x 30.5
Options			
with media feed-through (MDF)		SRM 12-H-180-90-M-4P	SRM 12-E-180-90-M-4P
ID		1482208	1482209

① The complete or supplementary technical data of all possible combinations can be found in the catalog below or at schunk.com.

Main view of basic version with hydraulic damping

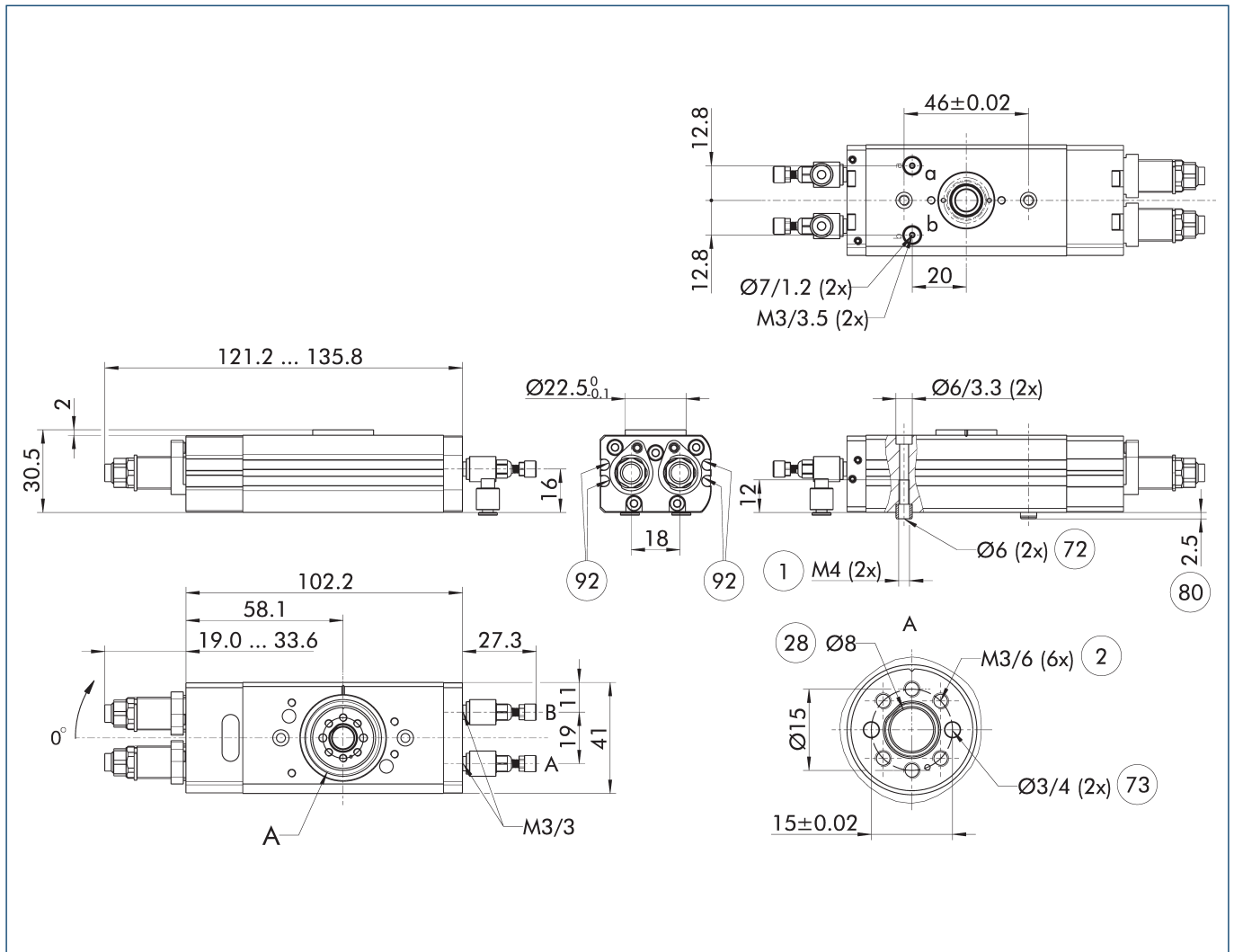

The drawing shows the unit in standard design, without considering any dimensions of the options described below.

① The SDV-P pressure maintenance valve can be used to maintain the position in the case of a loss of pressure (see "Accessories" catalog section).

A, a Main / direct connection, rotary actuator rotates clockwise

B, b Main / direct connection, rotary actuator rotates counterclockwise

① Connection swivel unit

② Attachment connection

②⑧ Through-hole

⑦② Fit for centering sleeves

⑦③ Fit for centering pins

⑧① Depth of the centering sleeve hole in the counter part

⑨② Sensor MMS 22..

Main view of basic version with elastomer damping

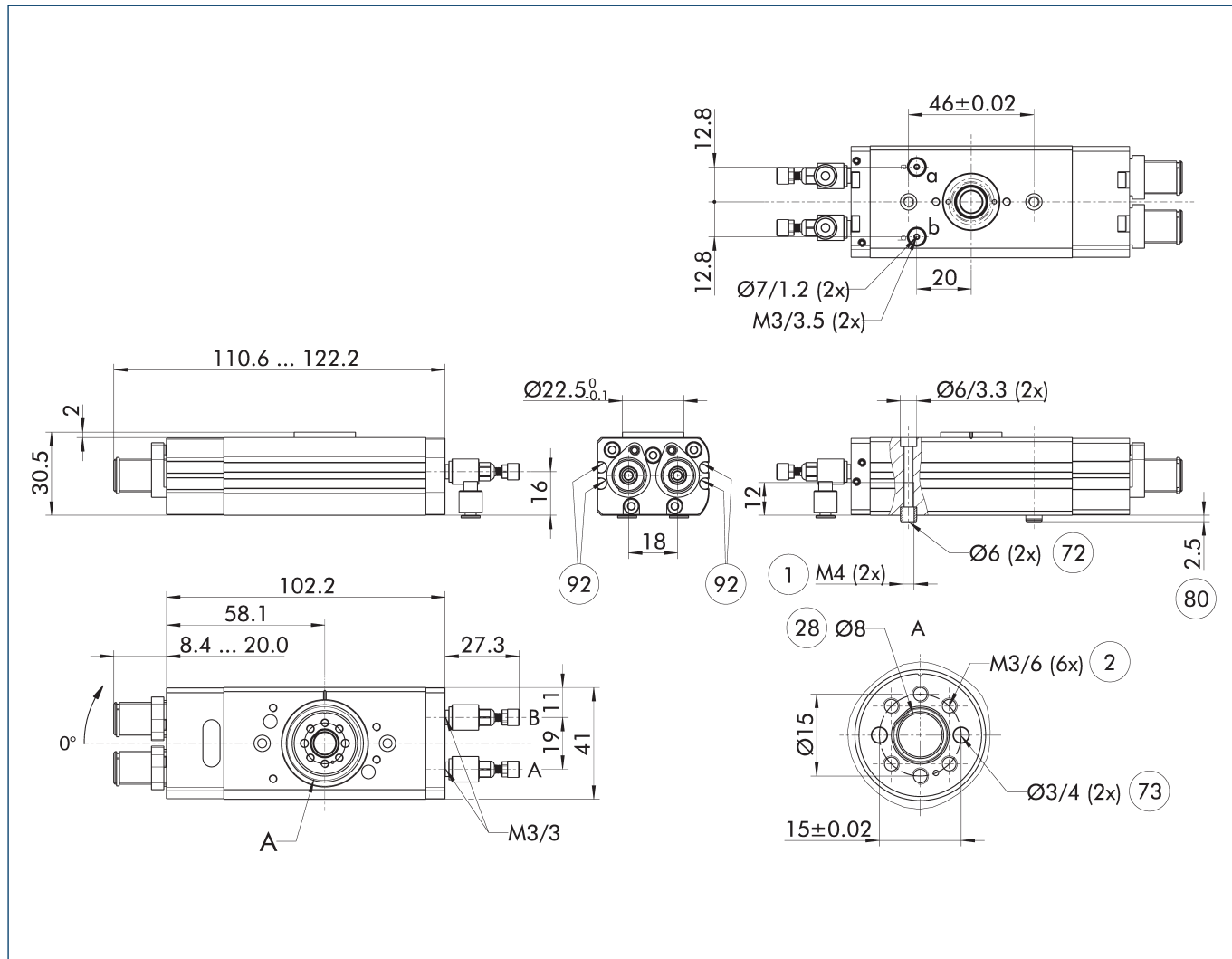

The drawing shows the unit in standard design, without considering any dimensions of the options described below.

① The SDV-P pressure maintenance valve can be used to maintain the position in the case of a loss of pressure (see "Accessories" catalog section).

- A, a Main / direct connection, rotary actuator rotates clockwise
- B, b Main / direct connection, rotary actuator rotates counterclockwise
- ① Connection swivel unit

- ② Attachment connection
- 28 Through-hole
- 72 Fit for centering sleeves
- 73 Fit for centering pins
- 80 Depth of the centering sleeve hole in the counter part
- 92 Sensor MMS 22..

Main view of basic version with speed damping

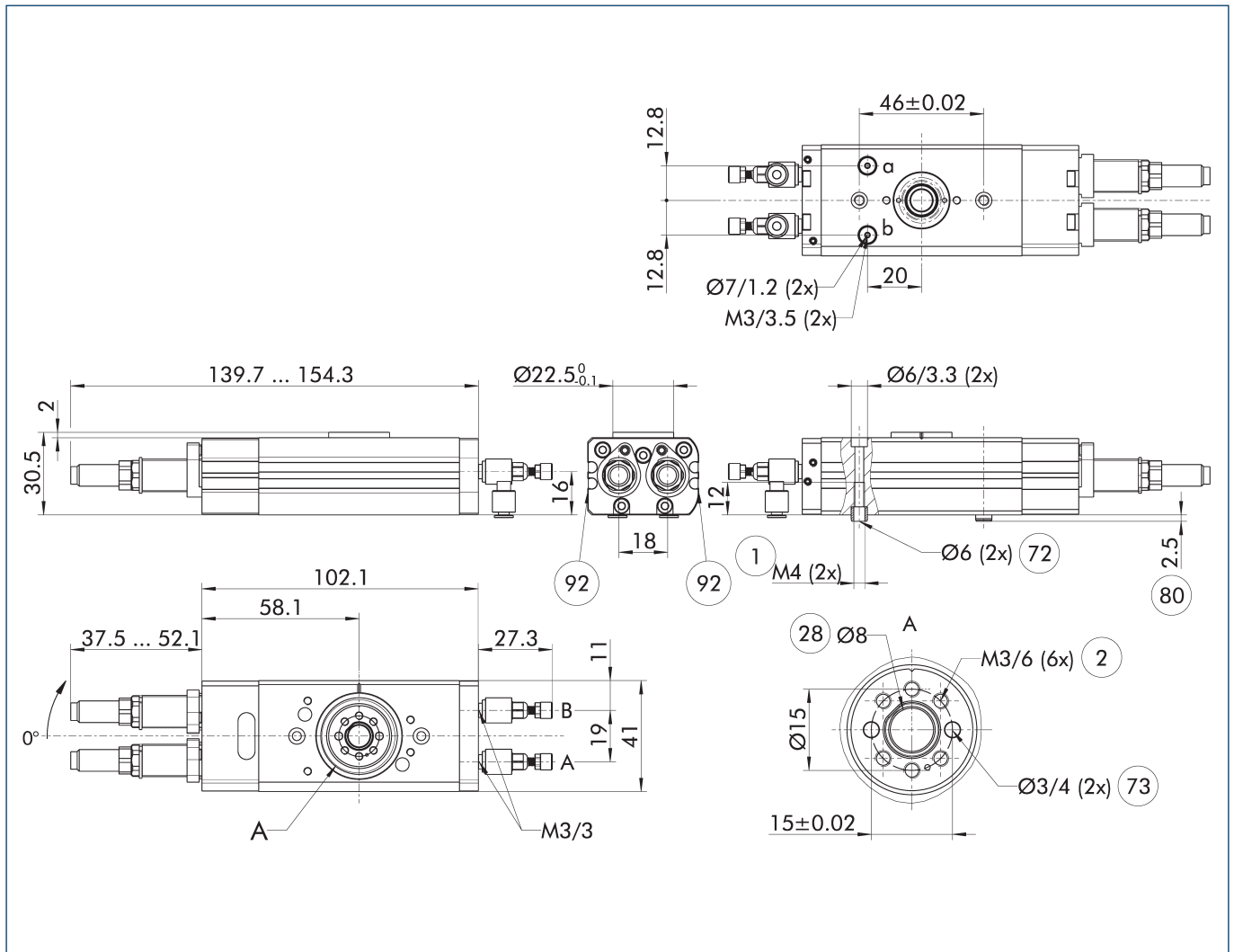

The drawing shows the unit in standard design, without considering any dimensions of the options described below.

① The SDV-P pressure maintenance valve can be used to maintain the position in the case of a loss of pressure (see "Accessories" catalog section).

A, a Main / direct connection, rotary actuator rotates clockwise

B, b Main / direct connection, rotary actuator rotates counterclockwise

① Connection swivel unit

② Attachment connection

②⑧ Through-hole

⑦② Fit for centering sleeves

⑦③ Fit for centering pins

⑧① Depth of the centering sleeve hole in the counter part

⑨② Sensor MMS 22..

Main view of basic version with external damping

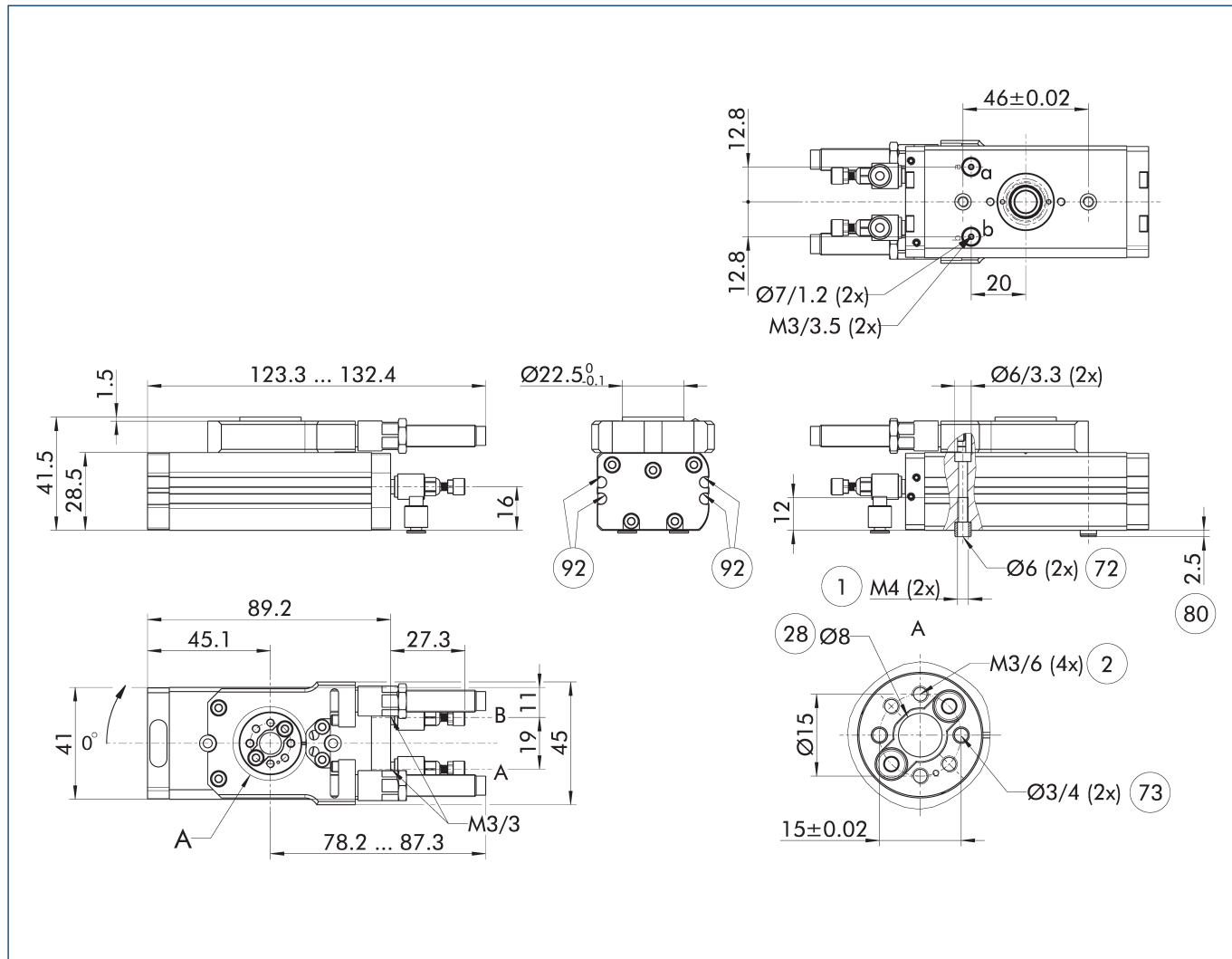

SRM 12

Universal swivel unit

Exemplary design

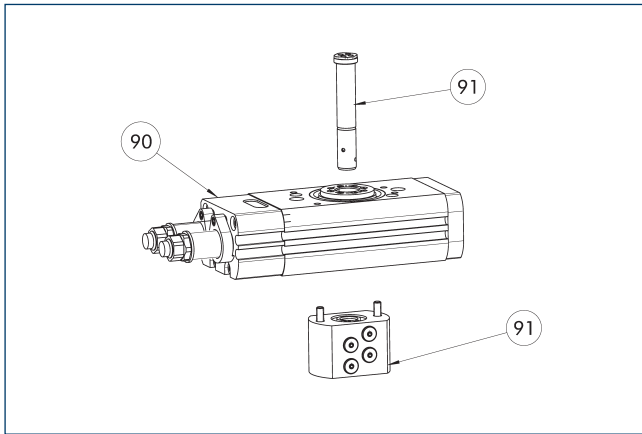

90 SRM basis

91 Option MDF

The drawing shows an example of the SRM with the maximum possible number of optional modules. The SRM can be ordered as a basic version without optional modules, with each option individually, or as a combination of several optional modules. The unit is supplied fully assembled. The options cannot be ordered separately. You can find a list of the available combinations including IDs in the technical data table.

Total height

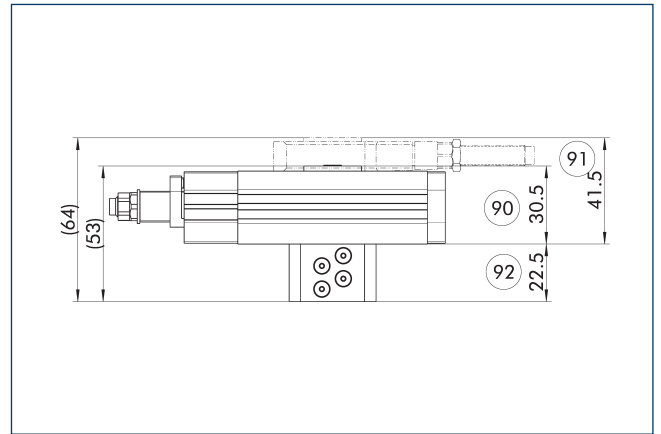

90 Total height SRM basic version (type of damping method H/E)

92 Additional dimension of the attached module, option MDF

91 Total height SRM basic (type of damping method X)

The drawing shows the maximum additional dimension. Depending on the selected optional modules, the total height is reduced accordingly

Main view option of media feed-through MDF

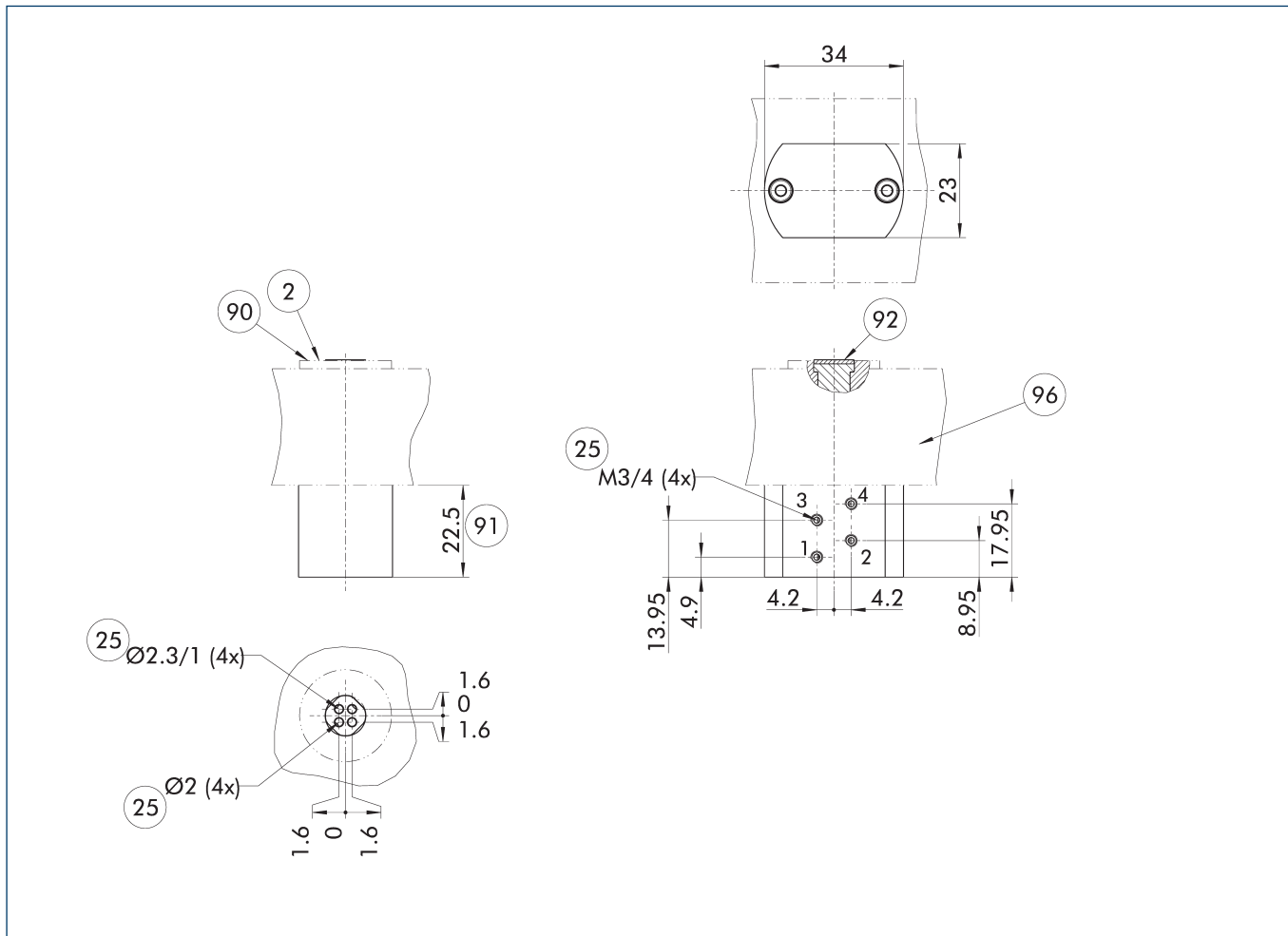

The drawing shows the option of media feed-through, without the base module or other options for the swivel unit.

- ② Attachment connection
- ②⑤ Fluid feed-through
- ②⑨ The screw connection diagram can be found in the drawing of the base unit.
- ⑨① Additional dimension of the attached module, option MDF
- ⑨② Seal
- ⑨⑥ SRM basis

Reduction of torque at 6 bar in the fluid feed-through	Weight of the module without base unit	No. of fluid feed-throughs	Min. pressure in the fluid feed-through	Max. pressure fluid feed-through	Max. volumetric flow of feed-through (at 6 bar)
[Nm]	[kg]		[bar]	[bar]	[l/min]
Option for media feed-through MDF					
- 0.05	0.047	4	-0.8	8	40

① This option cannot be ordered separately. It is a part of a configured version of the swivel unit. For the complete technical data of all the possible combination options, please configure the swivel unit at schunk.com. Please note that the above-mentioned data refer only to the option and not to the complete unit.

Hose-free direct connection M3

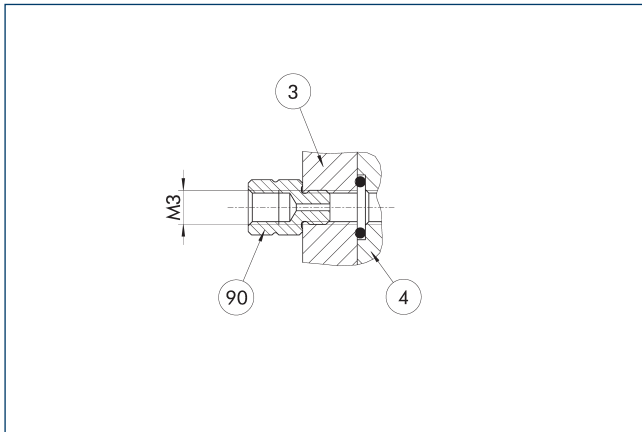

- ③ Adapter
- ④ Rotary unit
- ⑨⑩ Fixed throttle

The direct connection is used for compressed air supply without error-prone tubing. Instead, the pressure medium is fed through the bore-holes in the mounting plate. The required O-ring as well as the fixed throttle are enclosed to the product's accessory kit.

Adapter for SCHUNK gripper

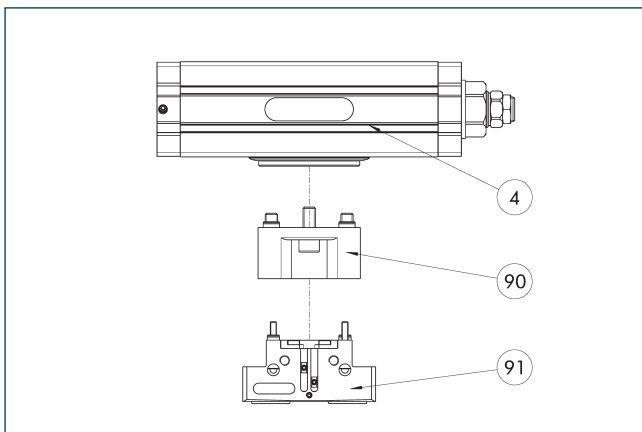

- ④ Rotary unit
- ⑨⑩ Adapter plate
- ⑨⑪ Grippers

Adapter plates are available for mounting many types of SCHUNK grippers. All combinations of swivel/gripping units, and associated adapter plates can be configured in the SCHUNK PARTCommunity and downloaded as a 3D model.

Pneumatic middle position (M)

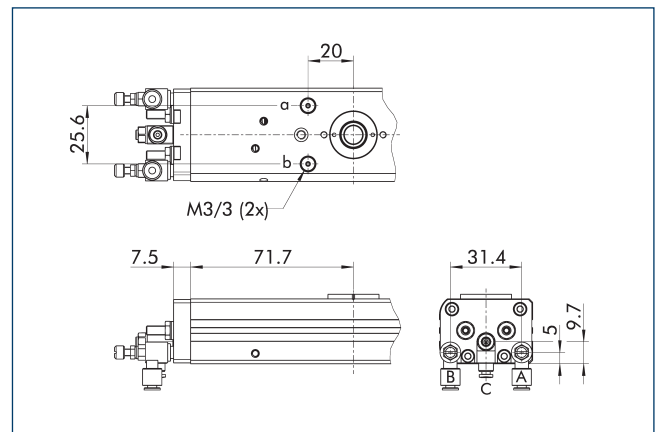

- A, a Main / direct connection, rotary actuator rotates clockwise
- B, b Main / direct connection, rotary actuator rotates counterclockwise
- C Main connection center position

The drawing shows the change in dimension of the "pneumatic center position (M)" option compared to the basic variant. Heavy attachments may swing before they reach the final position.

Angle adapter WA

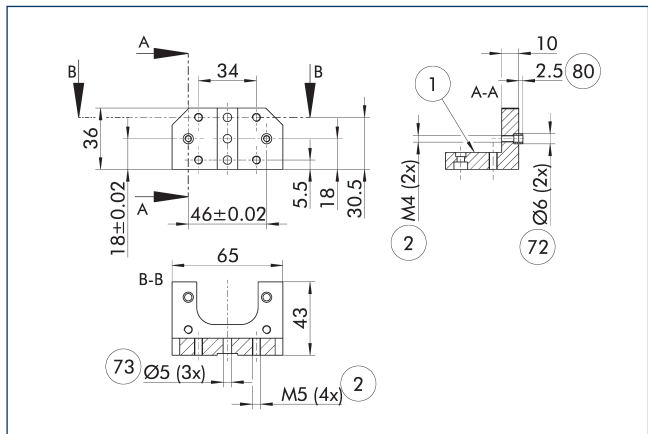

- ① Connection swivel unit
- ② Attachment connection
- ⑦③ Fit for centering pins
- ⑧① Depth of the centering sleeve hole in the counter part
- ⑦② Fit for centering sleeves

The angle adapter enables the swivel unit to be laterally connected with screws.

Description	ID
Adapter plate	
WA-SRM 10/12	1414971

Angle adapter WA

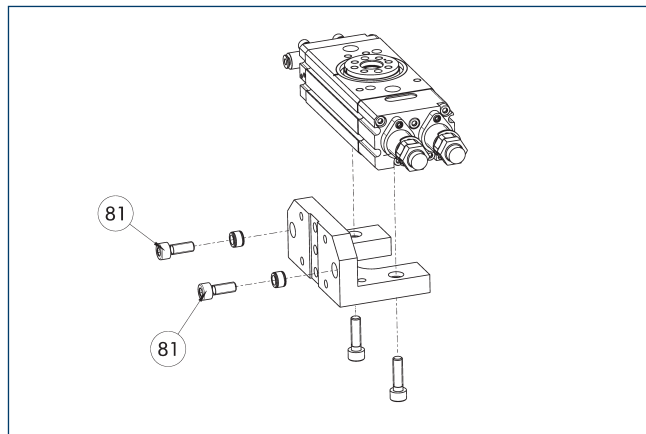

- ⑧① Not included in the scope of delivery

The angle adapter enables the swivel unit to be laterally connected with screws to the customer-specific superstructures or components from the modular assembly automation system.

Description	ID
Adapter plate	
WA-SRM 10/12	1414971

Electronic magnetic switch MMS

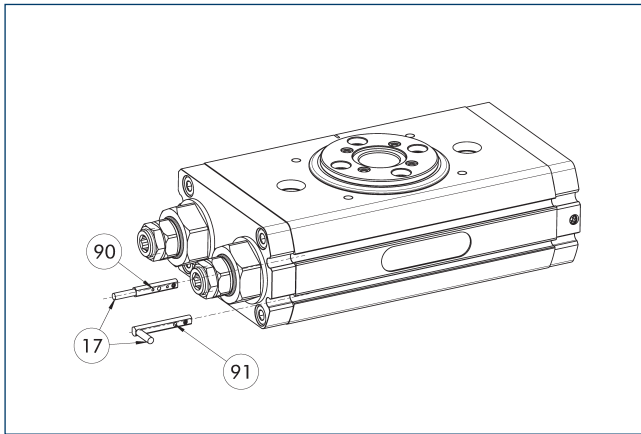

- ①⑦ Cable outlet
- ①⑨ Sensor MMS 22...
- ①⑩ Sensor MMS 22..
- ①⑪ Sensor MMS 22...-SA

End position monitoring for mounting in the C-slot.

Description	ID	Often combined
Electronic magnetic switch		
MMS 22-S-M8-PNP	0301032	●
MMSK 22-S-PNP	0301034	
Electronic magnetic switches with lateral cable outlet		
MMS 22-S-M8-PNP-SA	0301042	●
MMSK 22-S-PNP-SA	0301044	
Connection cables		
KA BG08-L 3P-0300-PNP	0301622	●
KA BG08-L 3P-0500-PNP	0301623	
KA BW08-L 3P-0300-PNP	0301594	
KA BW08-L 3P-0500-PNP	0301502	
Clip for connector/socket		
CLI-M8	0301463	
Cable extension		
KV BW08-SG08 3P-0030-PNP	0301495	
KV BW08-SG08 3P-0100-PNP	0301496	
KV BW08-SG08 3P-0200-PNP	0301497	●
Sensor distributor		
V2-M8	0301775	●
V4-M8	0301746	
V8-M8	0301751	

- ① Two sensors are required per unit for monitoring two positions. On option, extension cables and sensor distributors are available. Additional product variants of the sensor, and further information and technical data can be found in the catalog chapter sensor system.

SRM 14

Universal swivel unit

Dimensions and maximum loads

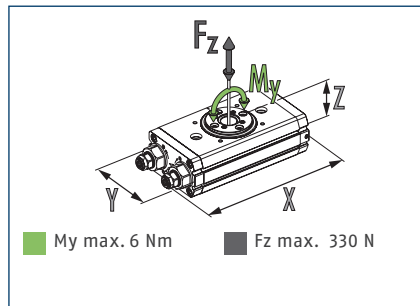
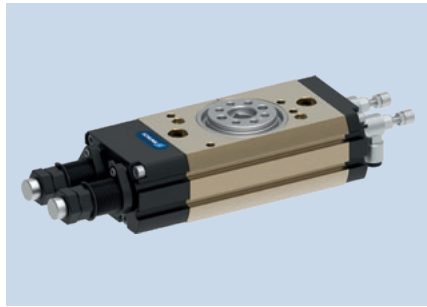

① The indicated moments and forces are static values, valid for the base unit, and may appear simultaneously. Throttling has to be done for ensuring that the rotary movement takes place without impact or bouncing. Otherwise the service life reduces.

Technical data SRM

Description		SRM 14-H-180-90	SRM 14-E-180-90	SRM 14-S-180-90	SRM 14-X-90-3	SRM 14-X-180-3
ID		1331278	1331258	1412969	1347008	1331282
End position damping		hydr. damper	Elastomer	hydr. damper	External damper	External damper
Angle of rotation	[°]	180.0	180.0	180.0	90.0	180.0
End position adjustability	[°]	+5/-95	+5/-95	+5/-95	+3/-3	+3/-3
Torque	[Nm]	1.15	1.15	1.15	1.15	1.15
Number of intermediate positions		none	none	none	none	none
IP protection class		40	40	40	40	40
Weight	[kg]	0.44	0.41	0.55	0.67	0.67
Fluid consumption (2x nom. angle)	[cm ³]	15.0	15.0	15.0	8.2	15.0
Min./nom./max. operating pressure	[bar]	3/6/6.5	4.5/6/6.5	3/6/6.5	3/6/6.5	3/6/6.5
Diameter of connecting hose		3 x 1.8 x 0.6	3 x 1.8 x 0.6	3 x 1.8 x 0.6	3 x 1.8 x 0.6	3 x 1.8 x 0.6
Min./max. ambient temperature	[°C]	5/60	5/75	5/60	5/60	5/60
Cleanroom class ISO 14644-1:2015		5	5	5	5	5
Repeat accuracy	[°]	0.03	0.06	0.03	0.03	0.03
Diameter of center bore	[mm]	9	9	9	9	9
Max. permissible mass moment of inertia	[kgm ²]	0.01	0.006	0.005	0.014	0.014
Dimensions X x Y x Z	[mm]	146.5 x 45 x 33	126.5 x 45 x 33	157 x 45 x 33	149.8 x 52 x 46.2	149.8 x 52 x 46.2
Options						
with media feed-through (MDF)		SRM 14-H-180-90-4P	SRM 14-E-180-90-4P	SRM 14-S-180-90-4P	SRM 14-X-90-3-4P	SRM 14-X-180-3-4P
ID		1331281	1331263	1413290	1347015	1331284

① The complete or supplementary technical data of all possible combinations can be found in the catalog below or at schunk.com.

Max. permissible inertia J*

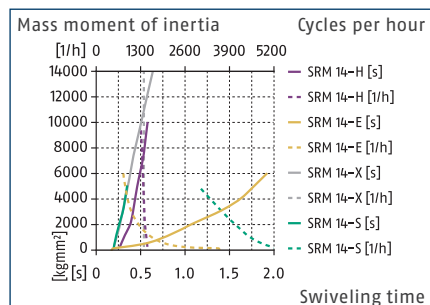

Max. permissible inertia J*

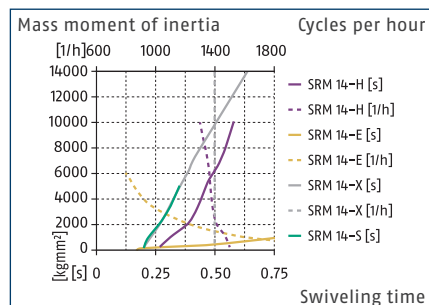

* *The diagrams are valid for basic units and for applications with a vertical swivel axis as well as for absolutely centric loads with a horizontal swivel axis and with an operating pressure of 6 bar. The swiveling times per throttling have to be observed, otherwise the life time may reduce. We will be happy to help you designing other applications. In addition, the SCHUNK Swiveling sizing assistant is available online.

Technical data SRM with center position

Description		SRM 14-H-180-90-M	SRM 14-E-180-90-M
ID		1457320	1457317
End position damping		hydr. damper	Elastomer
Angle of rotation	[°]	180.0	180.0
End position adjustability	[°]	+5/-95	+5/-95
Torque	[Nm]	1.15	1.15
Torque center position	[Nm]	0.8	0.8
Number of intermediate positions		1 x M (pneumatic)	1 x M (pneumatic)
Adjustability of middle position	[°]	+45/-45	+45/-45
IP protection class		40	40
Weight	[kg]	0.65	0.63
Fluid consumption (2x nom. angle)	[cm³]	19.0	19.0
Min./nom./max. operating pressure	[bar]	3/6/6.5	4.5/6/6.5
Diameter of connecting hose		3 x 1.8 x 0.6	3 x 1.8 x 0.6
Min./max. ambient temperature	[°C]	5/60	5/75
Cleanroom class ISO 14644-1:2015		5	5
Repeat accuracy	[°]	0.03	0.06
Diameter of center bore	[mm]	9	9
Max. permissible mass moment of inertia	[kgm²]	0.01	0.006
Dimensions X x Y x Z	[mm]	195 x 45 x 33	180 x 45 x 33
Options			
with media feed-through (MDF)		SRM 14-H-180-90-M-4P	SRM 14-E-180-90-M-4P
ID		1464297	1464298

① The complete or supplementary technical data of all possible combinations can be found in the catalog below or at schunk.com.

Main view of basic version with hydraulic damping

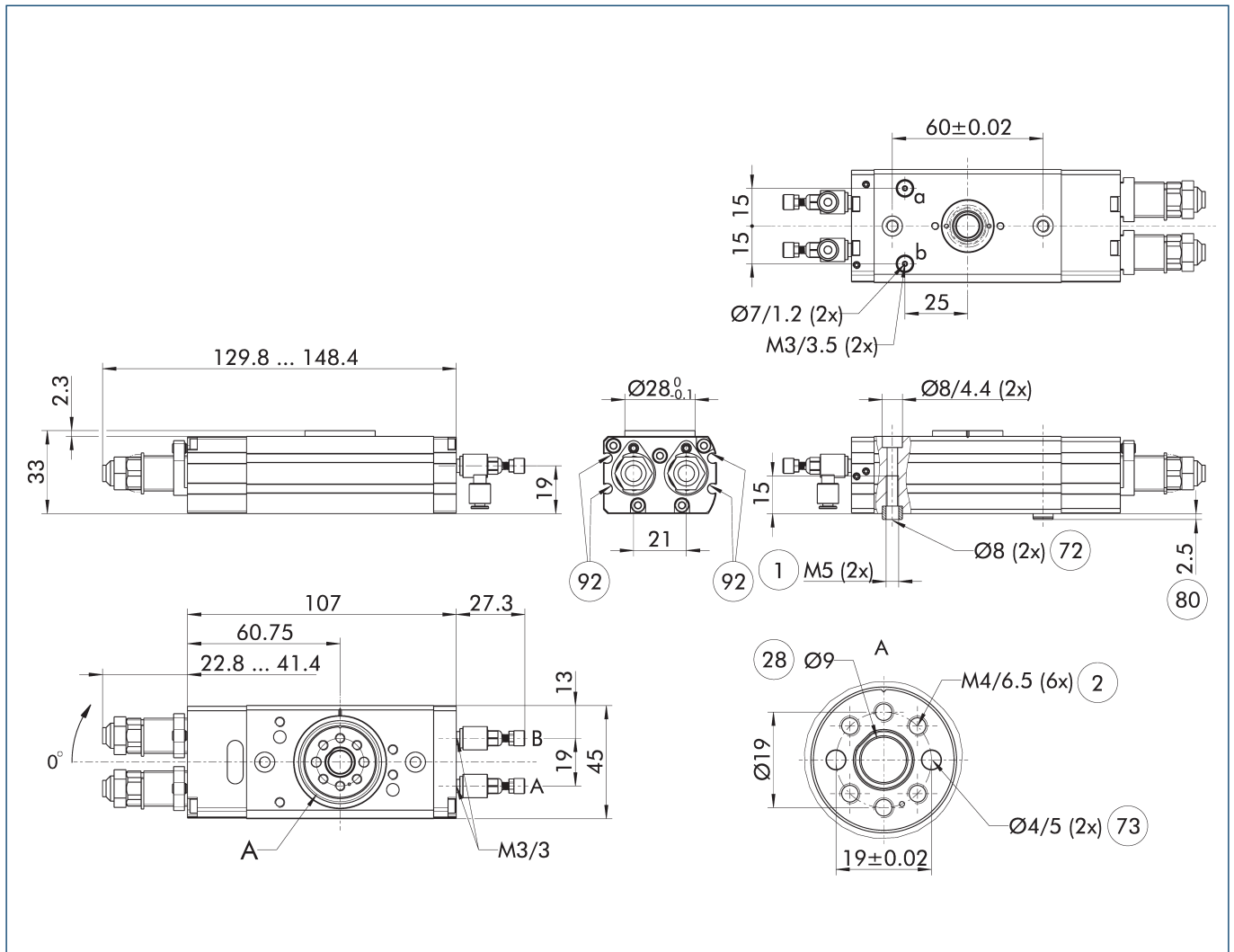

The drawing shows the unit in standard design, without considering any dimensions of the options described below.

① The SDV-P pressure maintenance valve can be used to maintain the position in the case of a loss of pressure (see "Accessories" catalog section).

A, a Main / direct connection, rotary actuator rotates clockwise

B, b Main / direct connection, rotary actuator rotates counterclockwise

① Connection swivel unit

② Attachment connection

②⑧ Through-hole

⑦② Fit for centering sleeves

⑦③ Fit for centering pins

⑧①① Depth of the centering sleeve hole in the counter part

⑨② Sensor MMS 22..

Main view of basic version with elastomer damping

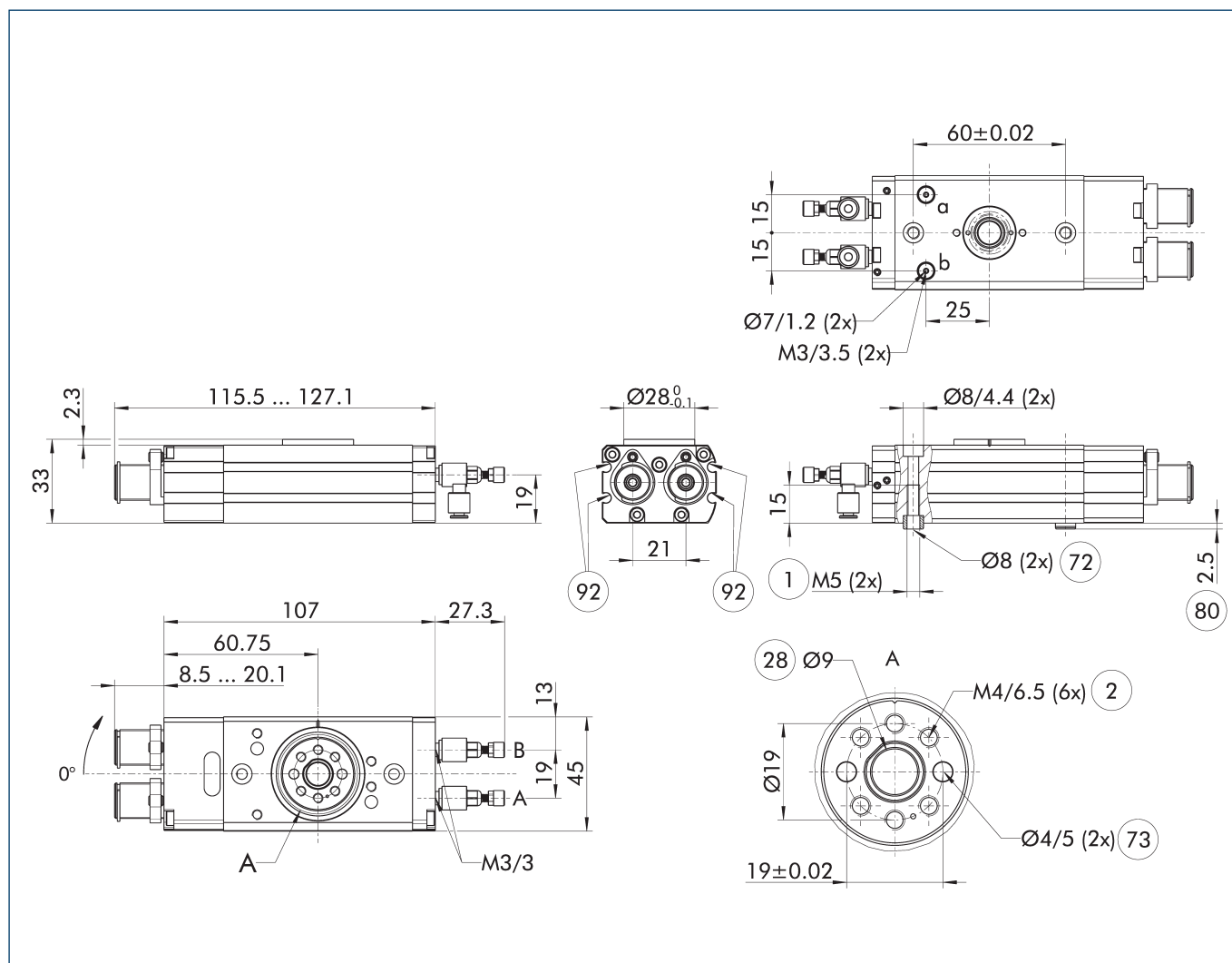

The drawing shows the unit in standard design, without considering any dimensions of the options described below.

① The SDV-P pressure maintenance valve can be used to maintain the position in the case of a loss of pressure (see "Accessories" catalog section).

- A, a Main / direct connection, rotary actuator rotates clockwise
- B, b Main / direct connection, rotary actuator rotates counterclockwise
- ① Connection swivel unit
- ② Attachment connection
- ②⑧ Through-hole
- ⑦② Fit for centering sleeves
- ⑦③ Fit for centering pins
- ⑧① Depth of the centering sleeve hole in the counter part
- ⑨② Sensor MMS 22..

Main view of basic version with speed damping

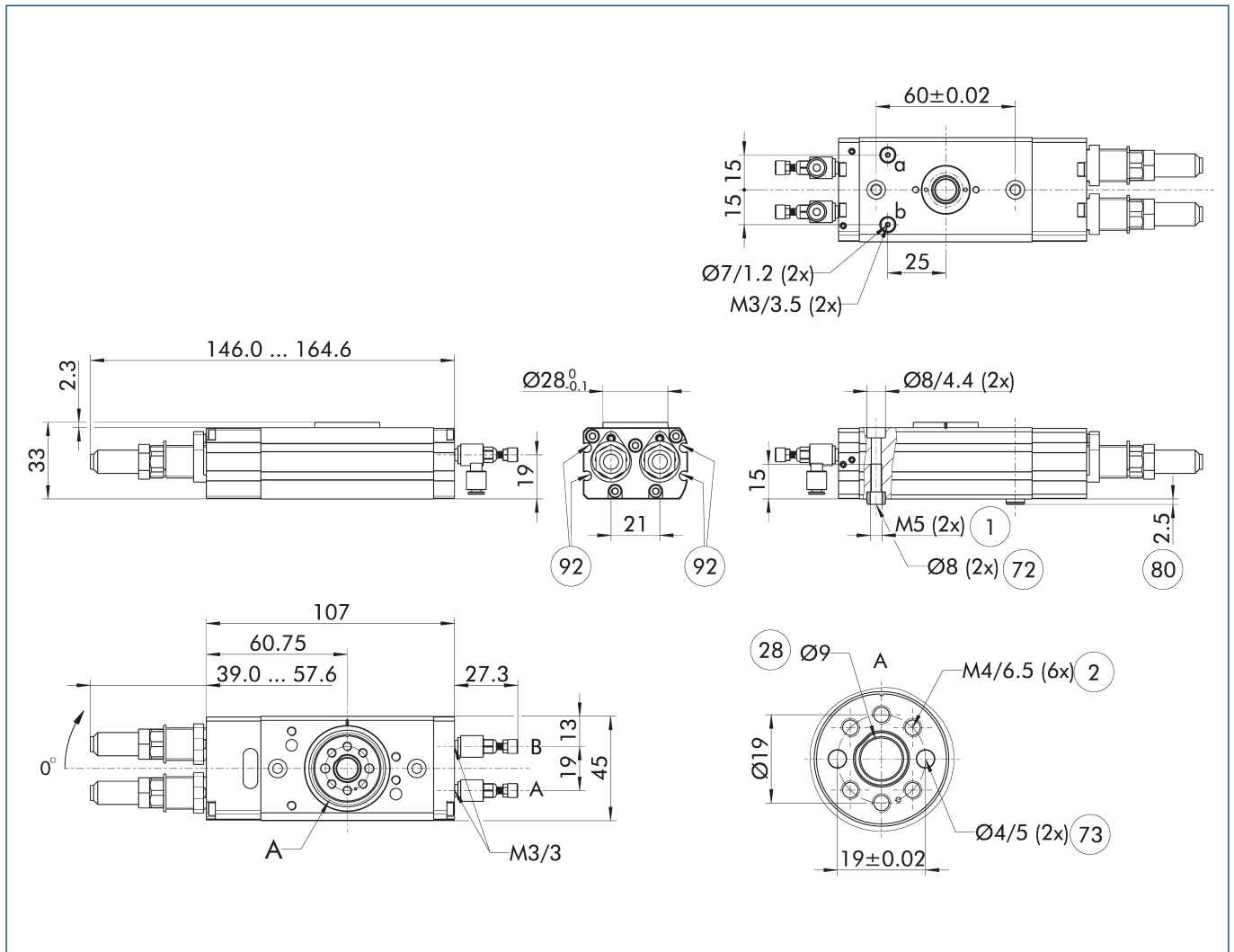

The drawing shows the unit in standard design, without considering any dimensions of the options described below.

① The SDV-P pressure maintenance valve can be used to maintain the position in the case of a loss of pressure (see "Accessories" catalog section).

A, a Main / direct connection, rotary actuator rotates clockwise

B, b Main / direct connection, rotary actuator rotates counterclockwise

① Connection swivel unit

② Attachment connection

②⑧ Through-hole

⑦② Fit for centering sleeves

⑦③ Fit for centering pins

⑧① Depth of the centering sleeve hole in the counter part

⑨② Sensor MMS 22..

Main view of basic version with external damping

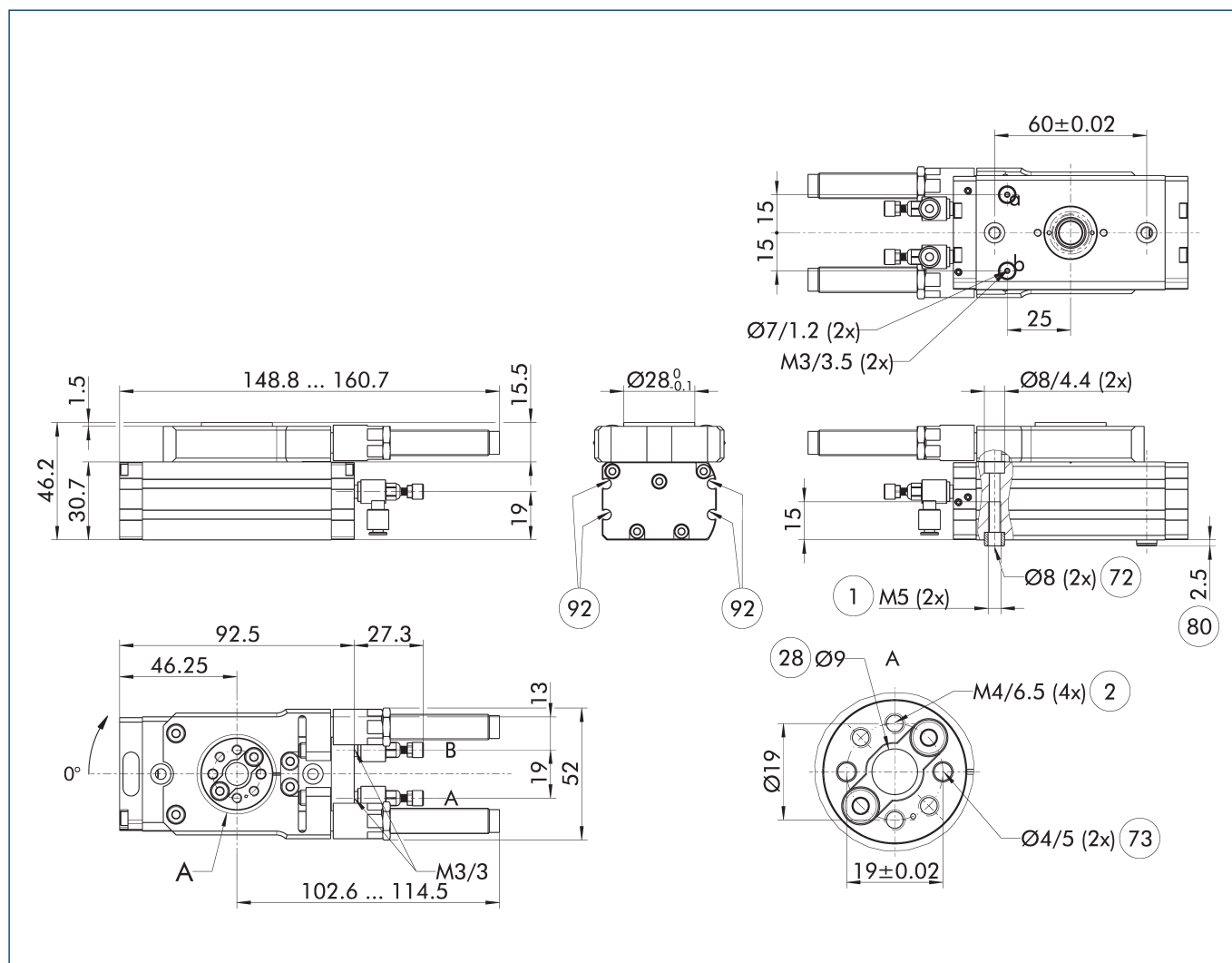

The drawing shows the unit in standard design, without considering any dimensions of the options described below.

① The SDV-P pressure maintenance valve can be used to maintain the position in the case of a loss of pressure (see "Accessories" catalog section).

- A, a Main / direct connection, rotary actuator rotates clockwise
- B, b Main / direct connection, rotary actuator rotates counterclockwise
- ① Connection swivel unit
- ② Attachment connection
- 28 Through-hole
- 72 Fit for centering sleeves
- 73 Fit for centering pins
- 80 Depth of the centering sleeve hole in the counter part
- 92 Sensor MMS 22..

SRM 14

Universal swivel unit

Exemplary design

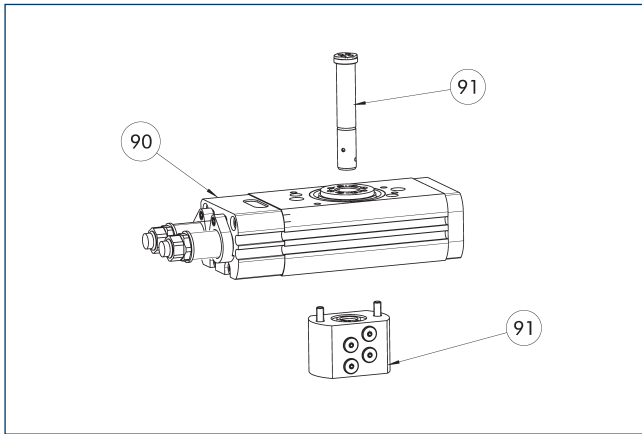

90 SRM basis

91 Option MDF

The drawing shows an example of the SRM with the maximum possible number of optional modules. The SRM can be ordered as a basic version without optional modules, with each option individually, or as a combination of several optional modules. The unit is supplied fully assembled. The options cannot be ordered separately. You can find a list of the available combinations including IDs in the technical data table.

Total height

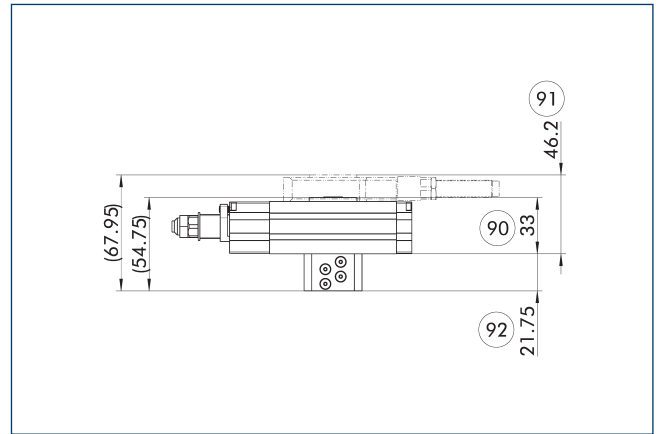

90 Total height SRM basic version (damping method H/E/S)

92 Additional dimension of the attached module, option MDF

91 Total height SRM basic (type of damping method X)

The drawing shows the maximum additional dimension. Depending on the selected optional modules, the total height is reduced accordingly

Main view option of media feed-through MDF

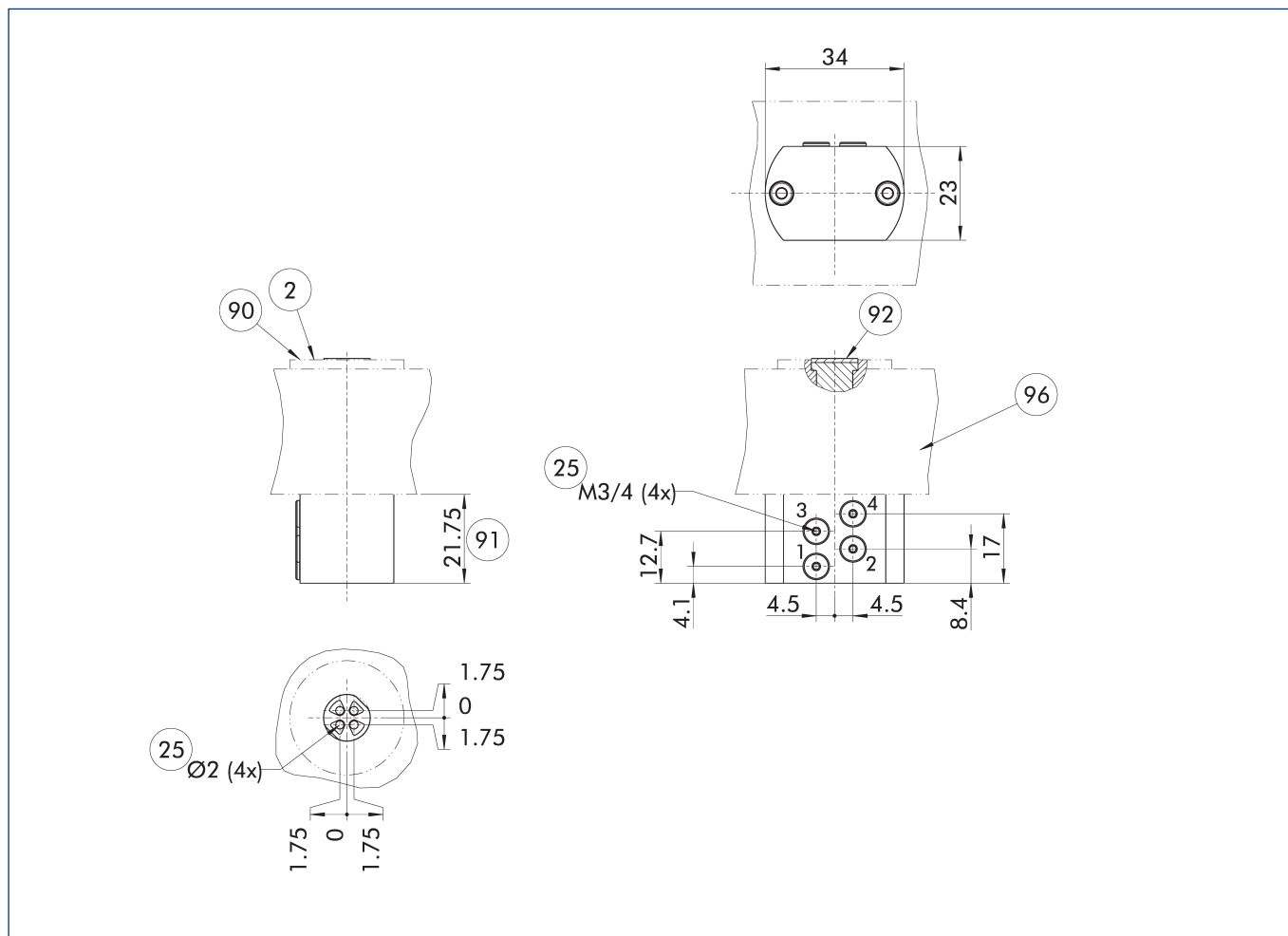

The drawing shows the option of media feed-through, without the base module or other options for the swivel unit.

- ② Attachment connection
- ②⑤ Fluid feed-through
- ②⑨ The screw connection diagram can be found in the drawing of the base unit.
- ②① Additional dimension of the attached module, option MDF
- ②② Seal
- ②⑥ SRM basis

Reduction of torque at 6 bar in the fluid feed-through	Weight of the module without base unit	No. of fluid feed-throughs	Min. pressure in the fluid feed-through	Max. pressure fluid feed-through	Max. volumetric flow of feed-through (at 6 bar)
[Nm]	[kg]		[bar]	[bar]	[l/min]
Option for media feed-through MDF					
- 0.15	0.05	4	-0.8	8	60

① This option cannot be ordered separately. It is a part of a configured version of the swivel unit. For the complete technical data of all the possible combination options, please configure the swivel unit at schunk.com. Please note that the above-mentioned data refer only to the option and not to the complete unit.

Hose-free direct connection M3

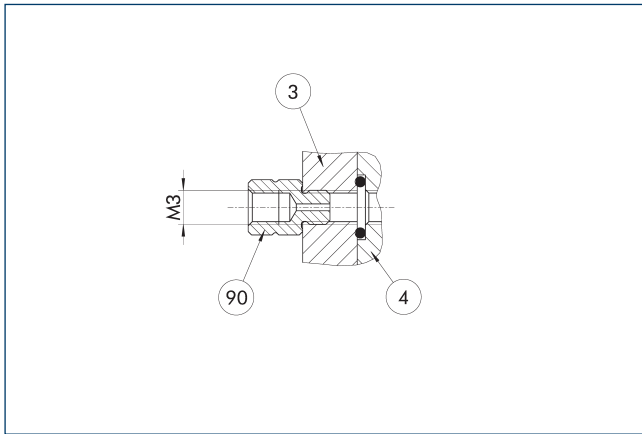

- ③ Adapter
- ④ Rotary unit
- ⑨⑩ Fixed throttle

The direct connection is used for compressed air supply without error-prone tubing. Instead, the pressure medium is fed through the bore-holes in the mounting plate. The required O-ring as well as the fixed throttle are enclosed to the product's accessory kit.

Adapter for SCHUNK gripper

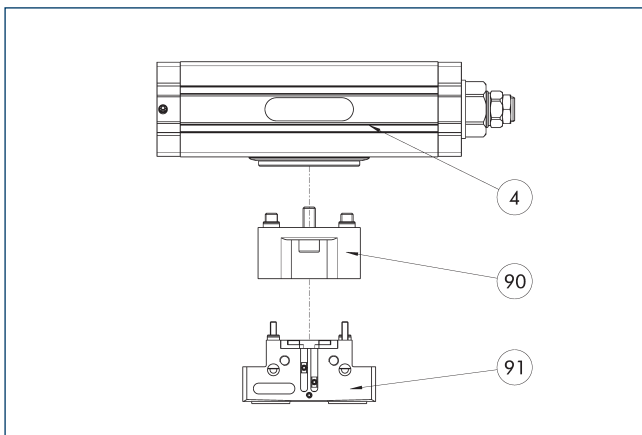

- ④ Rotary unit
- ⑨⑩ Adapter plate
- ⑨⑪ Grippers

Adapter plates are available for mounting many types of SCHUNK grippers. All combinations of swivel/gripping units, and associated adapter plates can be configured in the SCHUNK PARTCommunity and downloaded as a 3D model.

Pneumatic middle position (M)

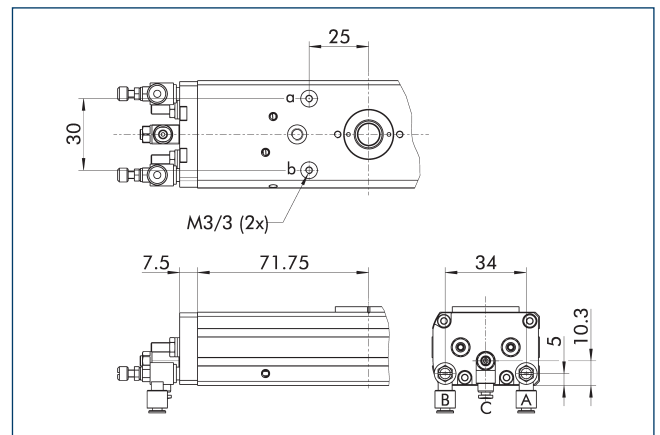

A, a Main / direct connection, rotary actuator rotates clockwise

B, b Main / direct connection, rotary actuator rotates counterclockwise

C Main connection center position

The drawing shows the change in dimension of the "pneumatic center position (M)" option compared to the basic variant. Heavy attachments may swing before they reach the final position.

Angle adapter WA

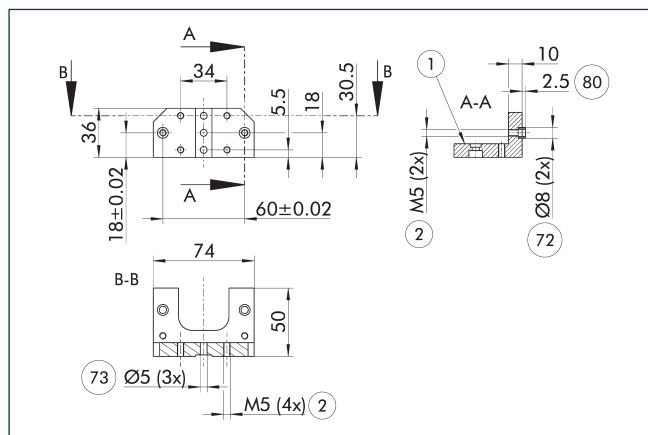

- ① Connection swivel unit
- ② Attachment connection
- ⑦③ Fit for centering pins
- ⑧① Depth of the centering sleeve hole in the counter part
- ⑦② Fit for centering sleeves

The angle adapter enables the swivel unit to be laterally connected with screws.

Description	ID
Adapter plate	
WA-SRM 14	1372525

Angle adapter WA

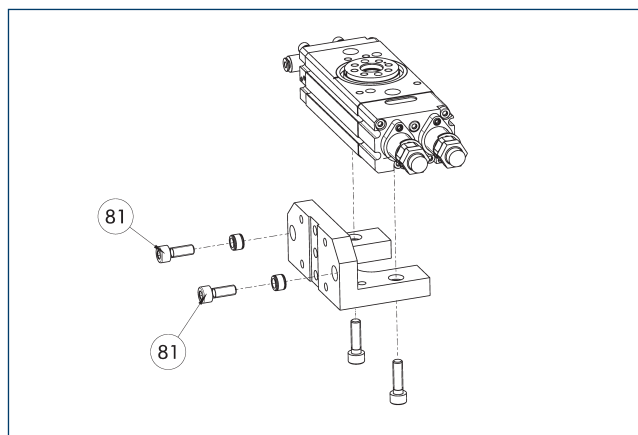

- ⑧① Not included in the scope of delivery

The angle adapter enables the swivel unit to be laterally connected with screws to the customer-specific superstructures or components from the modular assembly automation system.

Description	ID
Adapter plate	
WA-SRM 14	1372525

Electronic magnetic switch MMS

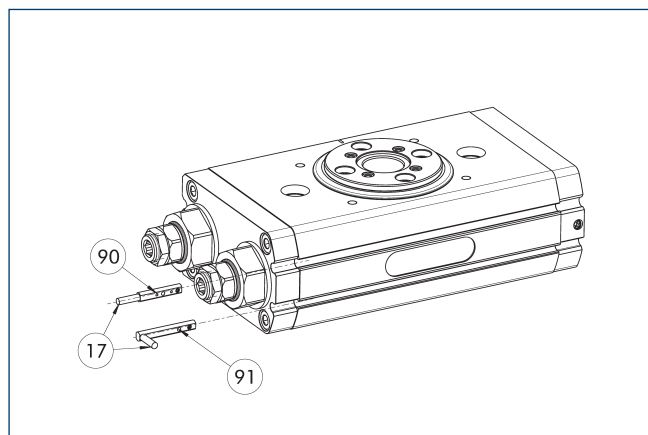

- 17 Cable outlet 91 Sensor MMS 22...-SA
90 Sensor MMS 22..

End position monitoring for mounting in the C-slot.

Description	ID	Often combined
Electronic magnetic switch		
MMS 22-S-M8-PNP	0301032	●
MMSK 22-S-PNP	0301034	
Electronic magnetic switches with lateral cable outlet		
MMS 22-S-M8-PNP-SA	0301042	●
MMSK 22-S-PNP-SA	0301044	
Connection cables		
KA BG08-L 3P-0300-PNP	0301622	●
KA BG08-L 3P-0500-PNP	0301623	
KA BW08-L 3P-0300-PNP	0301594	
KA BW08-L 3P-0500-PNP	0301502	
Clip for connector/socket		
CLI-M8	0301463	
Cable extension		
KV BW08-SG08 3P-0030-PNP	0301495	
KV BW08-SG08 3P-0100-PNP	0301496	
KV BW08-SG08 3P-0200-PNP	0301497	●
Sensor distributor		
V2-M8	0301775	●
V4-M8	0301746	
V8-M8	0301751	

- ① Two sensors are required per unit for monitoring two positions. On option, extension cables and sensor distributors are available. Additional product variants of the sensor, and further information and technical data can be found in the catalog chapter sensor system.

SRM 16

Universal swivel unit

Dimensions and maximum loads

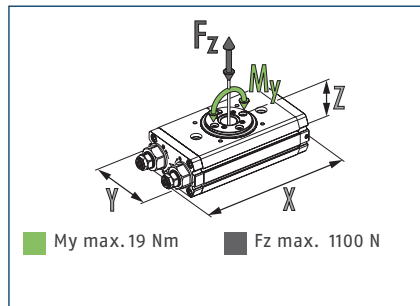
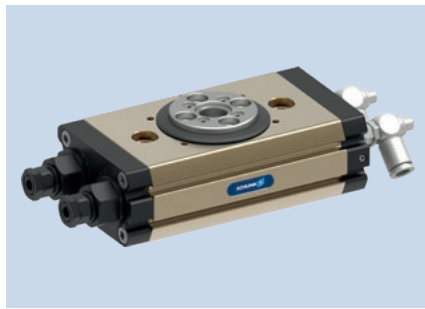

① The indicated moments and forces are static values, valid for the base unit, and may appear simultaneously. Throttling has to be done for ensuring that the rotary movement takes place without impact or bouncing. Otherwise the service life reduces.

Technical data SRM

Description	SRM 16-H-90-3	SRM 16-H-180-3	SRM 16-H-180-90
ID	1347181	1331286	1347230
End position damping	hydr. damper	hydr. damper	hydr. damper
Angle of rotation	[°] 90.0	180.0	180.0
End position adjustability	[°] +3/-3	+3/-3	+3/-93
Torque	[Nm] 1.47	1.47	1.47
Number of intermediate positions	none	none	none
IP protection class	65	65	65
Weight	[kg] 0.62	0.62	0.72
Fluid consumption (2x nom. angle)	[cm ³] 12.0	22.0	22.0
Min./nom./max. operating pressure	[bar] 4/6/6.5	4/6/6.5	4/6/6.5
Diameter of connecting hose	6 x 3.9 x 1.05	6 x 3.9 x 1.05	6 x 3.9 x 1.05
Min./max. ambient temperature	[°C] 5/60	5/60	5/60
Cleanroom class ISO 14644-1:2015	5	5	5
Repeat accuracy	[°] 0.06	0.06	0.06
Diameter of center bore	[mm] 10.5	10.5	10.5
Max. permissible mass moment of inertia	[kgm ²] 0.08	0.08	0.08
Dimensions X x Y x Z	[mm] 125.5 x 56.5 x 36.5	125.5 x 56.5 x 36.5	152.5 x 56.5 x 36.5
Options			
with media feed-through (MDF)	SRM 16-H-90-3-4P	SRM 16-H-180-3-4P	SRM 16-H-180-90-4P
ID	1468367	1468365	1468369
with electrical feed-throughs (EDF)	SRM 16-H-90-3-6E	SRM 16-H-180-3-6E	SRM 16-H-180-90-6E
ID	1347189	1331289	1347249
for inductive Sensors, adjustable (SI)	SRM 16-H-90-3-SI	SRM 16-H-180-3-SI	SRM 16-H-180-90-SI
ID	1347203	1347140	1347257
for inductive Sensors, fixed (SF)	SRM 16-H-90-3-SF	SRM 16-H-180-3-SF	SRM 16-H-180-90-SF
ID	1357447	1357409	1357425
with MDF and SI	SRM 16-H-90-3-4P-SI	SRM 16-H-180-3-4P-SI	SRM 16-H-180-90-4P-SI
ID	1468368	1468366	1468370
with MDF and SF	SRM 16-H-90-3-4P-SF	SRM 16-H-180-3-4P-SF	SRM 16-H-180-90-4P-SF
ID	1468373	1468371	1468372
with EDF and SI	SRM 16-H-90-3-6E-SI	SRM 16-H-180-3-6E-SI	SRM 16-H-180-90-6E-SI
ID	1347224	1347167	1347266
with EDF and SF	SRM 16-H-90-3-6E-SF	SRM 16-H-180-3-6E-SF	SRM 16-H-180-90-6E-SF
ID	1357459	1357422	1357431

① The complete or supplementary technical data of all possible combinations can be found in the catalog below or at schunk.com.

Max. permissible inertia J*

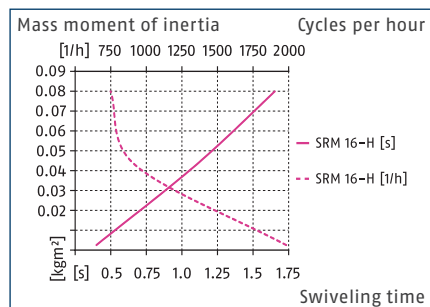

* *The diagrams are valid for basic units and for applications with a vertical swivel axis as well as for absolutely centric loads with a horizontal swivel axis and with an operating pressure of 6 bar. The swiveling times per throttling have to be observed, otherwise the life time may reduce. We will be happy to help you designing other applications. In addition, the SCHUNK Swiveling sizing assistant is available online.

Technical data SRM with center position

Description	SRM 16-H-180-3-M	SRM 16-H-180-90-M
ID	1455606	1455607
End position damping	hydr. damper	hydr. damper
Angle of rotation	[°] 180.0	180.0
End position adjustability	[°] +3/-3	+3/-93
Torque	[Nm] 1.47	1.47
Torque center position	[Nm] 1.0	1.0
Number of intermediate positions	1 x M (pneumatic)	1 x M (pneumatic)
Adjustability of middle position	[°] +3/-3	+3/-3
IP protection class	65	65
Weight	[kg] 0.85	0.95
Fluid consumption (2x nom. angle)	[cm³] 30.0	30.0
Min./nom./max. operating pressure	[bar] 4/6/6.5	4/6/6.5
Diameter of connecting hose	6 x 3.9 x 1.05	6 x 3.9 x 1.05
Min./max. ambient temperature	[°C] 5/60	5/60
Cleanroom class ISO 14644-1:2015	5	5
Repeat accuracy	[°] 0.06	0.06
Diameter of center bore	[mm] 10.5	10.5
Max. permissible mass moment of inertia	[kgm²] 0.03	0.03
Dimensions X x Y x Z	[mm] 190 x 56.5 x 36.5	217 x 56.5 x 36.5
Options		
with media feed-through (MDF)	SRM 16-H-180-3-M-4P	SRM 16-H-180-90-M-4P
ID	1468374	1468375
with electrical feed-throughs (EDF)	SRM 16-H-180-3-M-6E	SRM 16-H-180-90-M-6E
ID	1455680	1455681
for inductive Sensors, adjustable (SI)	SRM 16-H-180-3-M-SI	SRM 16-H-180-90-M-SI
ID	1455684	1455685
for inductive Sensors, fixed (SF)	SRM 16-H-180-3-M-SF	SRM 16-H-180-90-M-SF
ID	1455692	1455693
with MDF and SI	SRM 16-H-180-3-M-4P-SI	SRM 16-H-180-90-M-4P-SI
ID	1468376	1468377
with MDF and SF	SRM 16-H-180-3-M-4P-SF	SRM 16-H-180-90-M-4P-SF
ID	1468378	1468379
with EDF and SI	SRM 16-H-180-3-M-6E-SI	SRM 16-H-180-90-M-6E-SI
ID	1455688	1455689
with EDF and SF	SRM 16-H-180-3-M-6E-SF	SRM 16-H-180-90-M-6E-SF
ID	1455696	1455697

① The complete or supplementary technical data of all possible combinations can be found in the catalog below or at schunk.com.

Main view of basic version with hydraulic damping

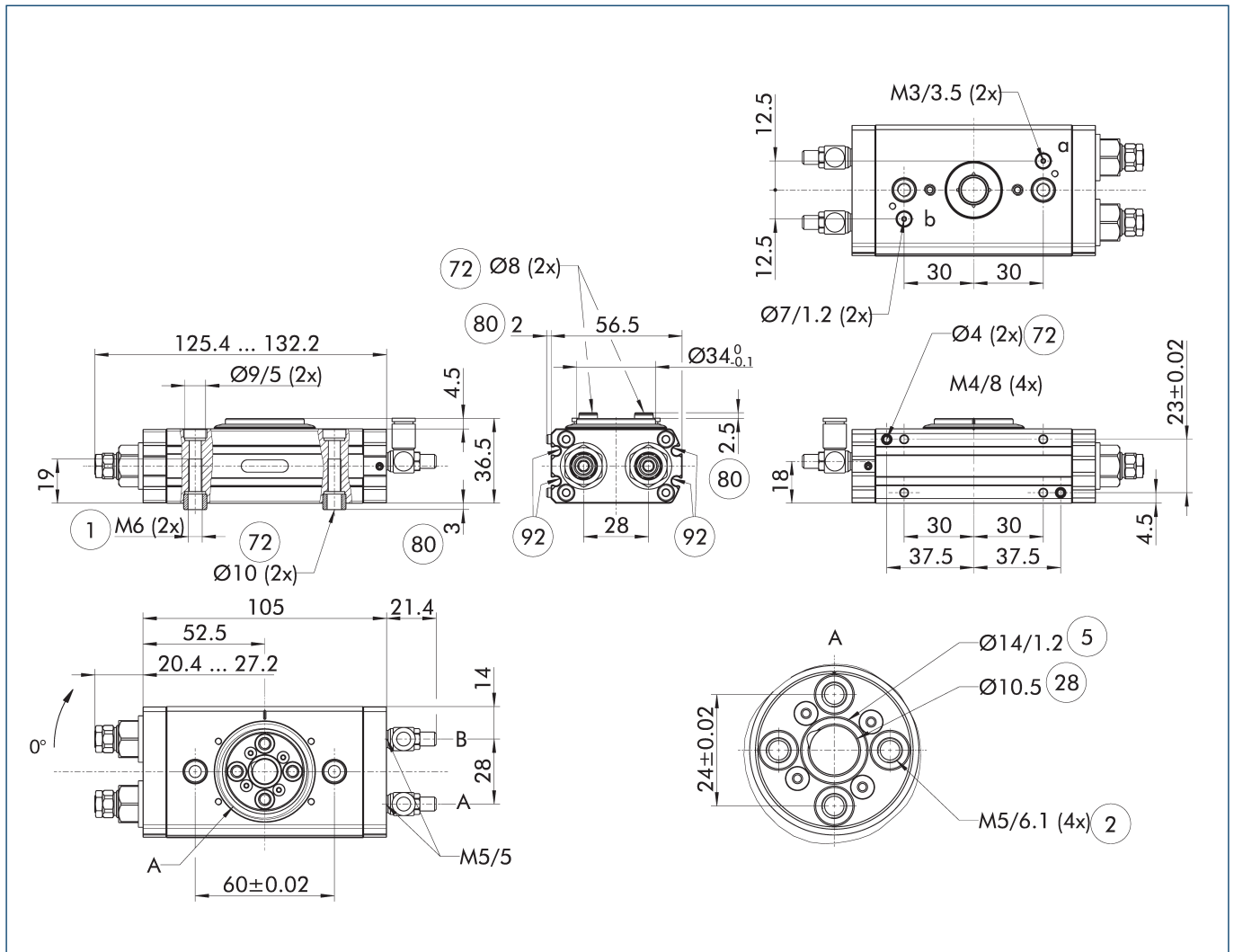

The drawing shows the unit in standard design, without considering any dimensions of the options described below.

① The SDV-P pressure maintenance valve can be used to maintain the position in the case of a loss of pressure (see "Accessories" catalog section).

A, a Main / direct connection, rotary actuator rotates clockwise

B, b Main / direct connection, rotary actuator rotates counterclockwise

① Connection swivel unit

② Attachment connection

⑤ O-ring

②⑧ Through-hole

⑦② Fit for centering sleeves

⑧①① Depth of the centering sleeve hole in the counter part

⑨② Sensor MMS 22..

Example of design with MDF

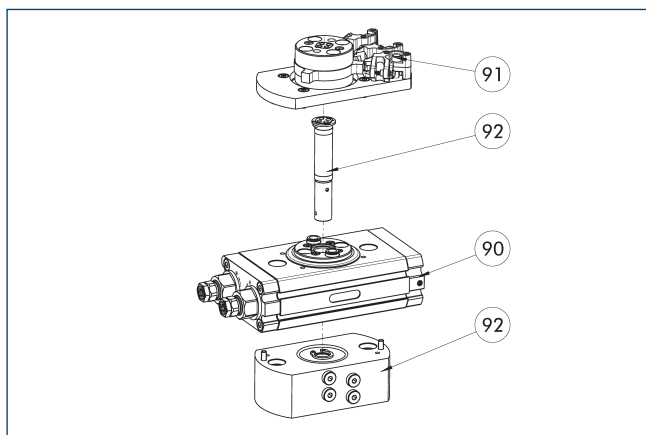

- 90 SRM basis
- 91 Option SI
- 92 Option MDF

The drawing shows an example of the SRM with the maximum possible number of optional modules. The SRM can be ordered as a basic version without optional modules, with each option individually, or as a combination of several optional modules. The unit is supplied fully assembled. The options cannot be ordered separately. You can find a list of the available combinations including IDs in the technical data table.

Example of design with EDF

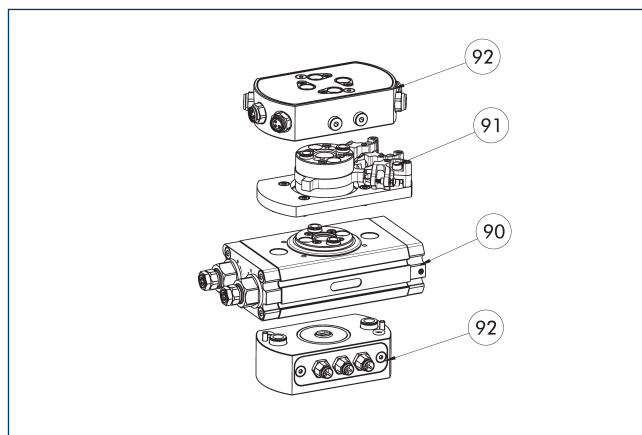

- 90 SRM basis
- 91 Option SI
- 92 Option EDF

The drawing shows an example of the SRM with the maximum possible number of optional modules. The SRM can be ordered as a basic version without optional modules, with each option individually, or as a combination of several optional modules. The unit is supplied fully assembled. The options cannot be ordered separately. You can find a list of the available combinations including IDs in the technical data table.

Total height with MDF

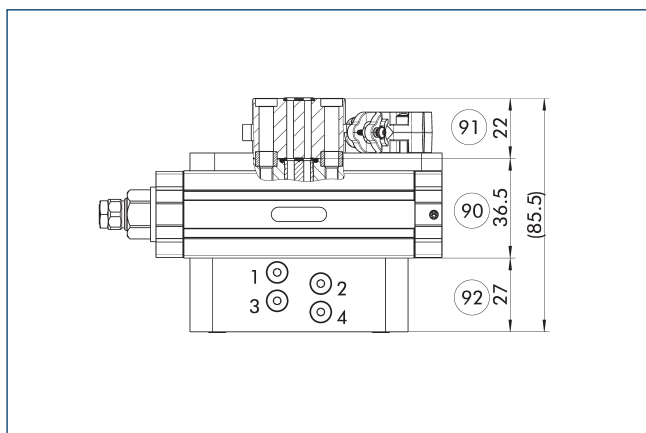

- 90 Total height SRM basic version
- 91 Additional dimension of the attached module, option SI/SF
- 92 Additional dimension of the attached module, option MDF

The drawing shows the maximum additional dimension. Depending on the selected optional modules, the total height is reduced accordingly

Total height with EDF

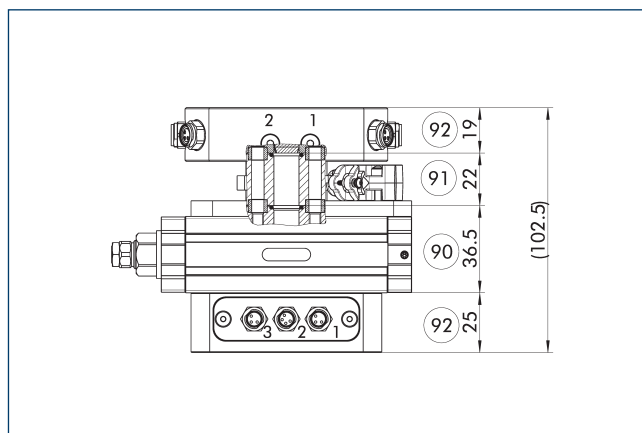

- 90 Total height SRM basic version
- 91 Additional dimension of the attached module, option SI/SF
- 92 Additional dimension of the attached module, option EDF

The drawing shows the maximum additional dimension. Depending on the selected optional modules, the total height is reduced accordingly

SRM 16

Universal swivel unit

Main view option of media feed-through MDF

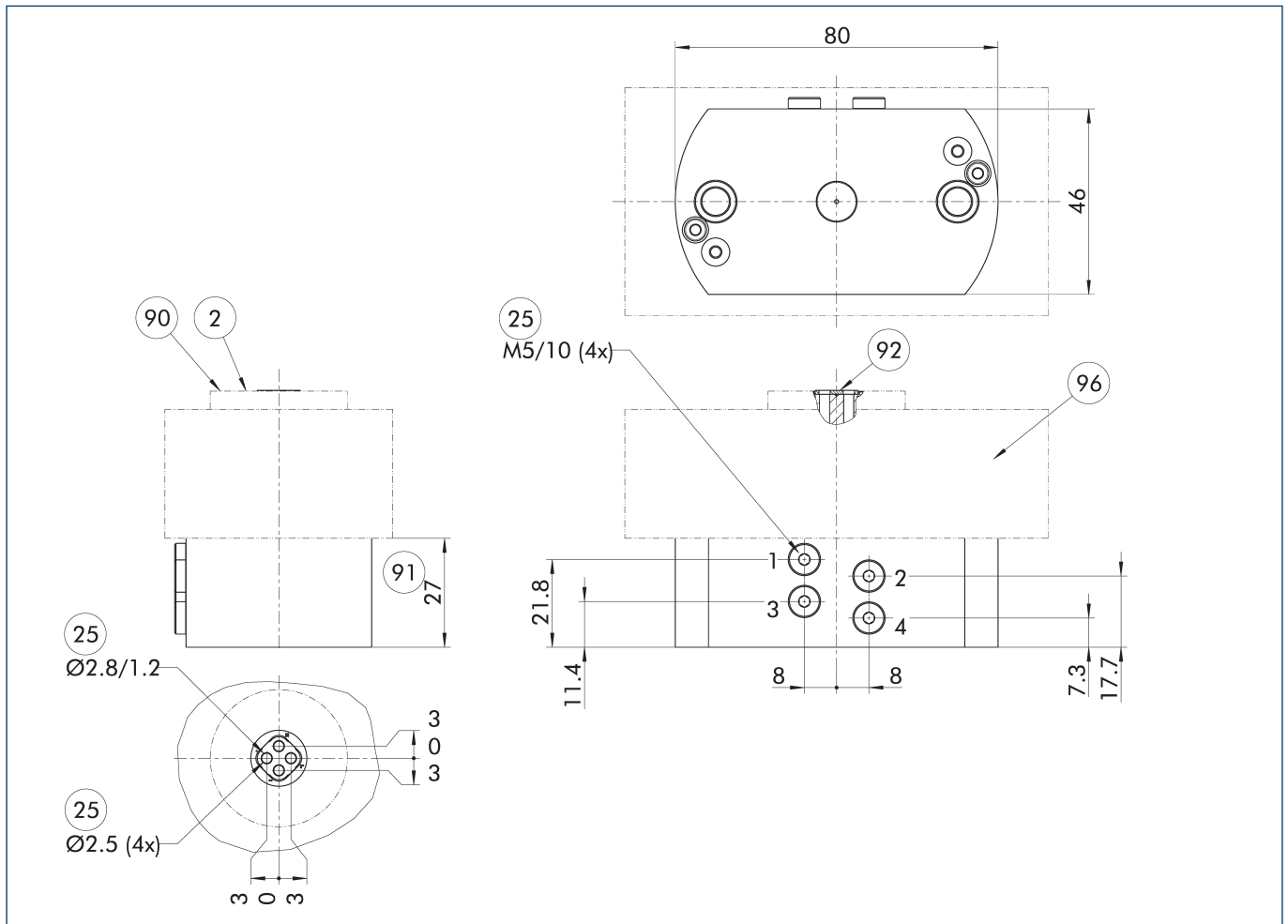

The drawing shows the option of media feed-through, without the base module or other options for the swivel unit.

- ② Attachment connection
- ②⑤ Fluid feed-through
- ⑨⑩ The screw connection diagram can be found in the drawing of the base unit.
- ⑨① Additional dimension of the attached module, option MDF
- ⑨② Seal
- ⑨⑥ SRM basis

Reduction of torque at 6 bar in the fluid feed-through	Weight of the module without base unit	No. of fluid feed-throughs	Min. pressure in the fluid feed-through	Nominal pressure of fluid feed-through	Max. pressure fluid feed-through	Max. volumetric flow of feed-through (at 6 bar)
[Nm]	[kg]		[bar]	[bar]	[bar]	[l/min]
Option for media feed-through MDF						
- 0.47	0.28	4	-0.8	6	8	120

① This option cannot be ordered separately. It is a part of a configured version of the swivel unit. For the complete technical data of all the possible combination options, please configure the swivel unit at schunk.com. The MDF and EDF options cannot be combined for size 16. Please note that the above-mentioned data refer only to the option and not to the complete unit.

Main view option of electric rotary feed-through EDF

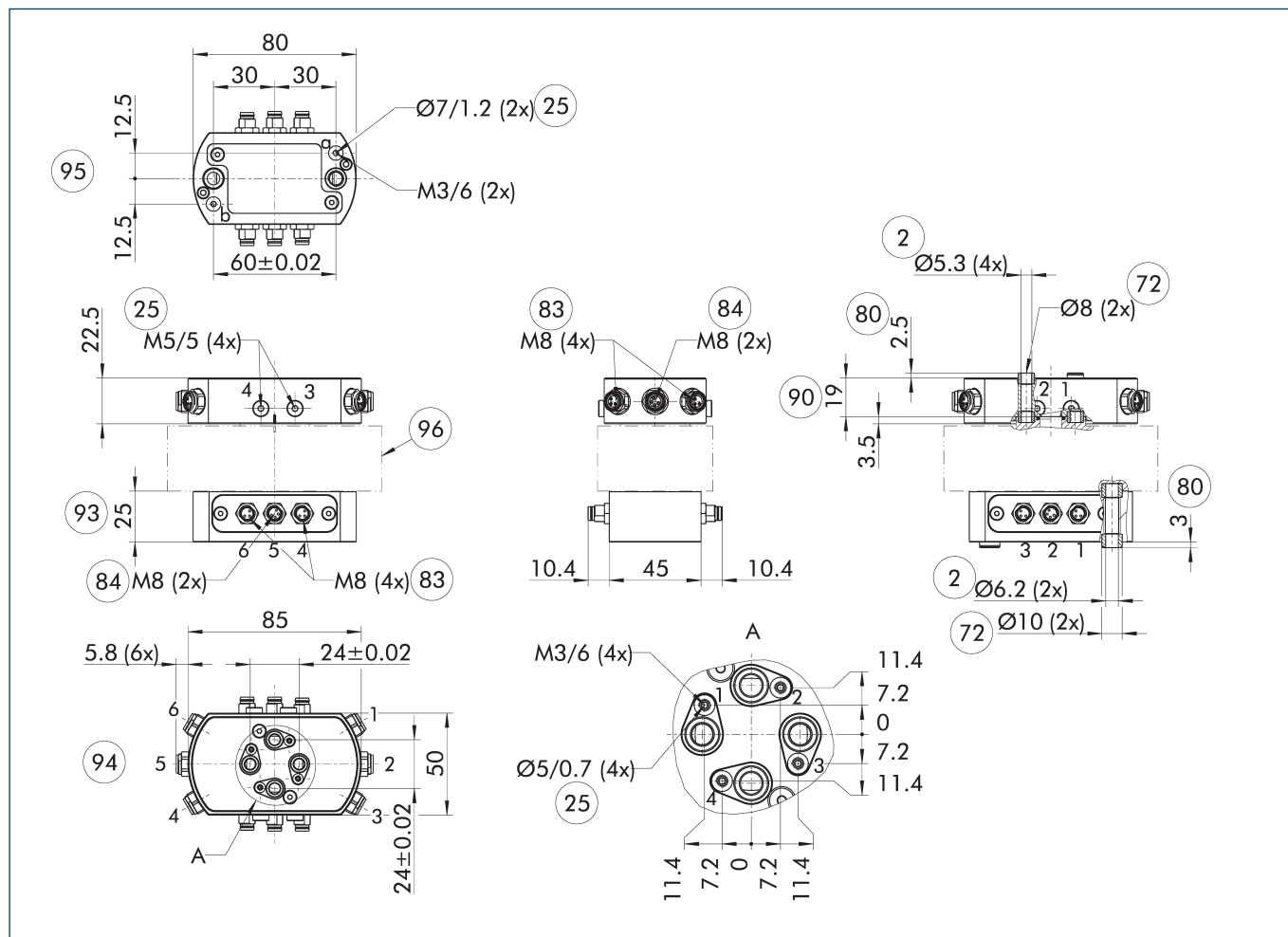

The drawing shows the option of an electric rotary feed-through without the base module or other options for the swivel unit.

- A, a Main / direct connection, rotary actuator rotates clockwise
- B, b Main / direct connection, rotary actuator rotates counterclockwise
- ② Attachment connection
- ②⑤ Fluid feed-through
- ⑦② Fit for centering sleeves
- ⑧① Depth of the centering sleeve hole in the counter part
- ⑧③ Input for 3 pole sensor feed-through
- ⑧④ Input for 4 pole sensor feed-through
- ⑨① Additional dimension of the attached module, option EDF output side
- ⑨③ Additional dimension of the attached module, option EDF drive side
- ⑨④ EDF drive side hidden from view
- ⑨⑤ EDF output side hidden from view
- ⑨⑥ SRM basis and other options

Weight of the module without base unit [kg]	Size of the socket (output)	Size of the connector (drive)	Number of wires	Max. voltage [V]	Max. current per wire [A]	Max. ambient temperature [°C]
Optional electric rotary feed-through EDF						
0.34	4xM8/3-polig 2xM8/4-polig	4xM8/3-polig 2xM8/4-polig	20	48	1	60

① This option cannot be ordered separately. It is a part of a configured version of the swivel unit. For the complete technical data of all the possible combination options, please configure the swivel unit at schunk.com. The MDF and EDF options cannot be combined for size 16. Please note that the above-mentioned data refer only to the option and not to the complete unit.

SRM 16

Universal swivel unit

Main view option for inductive proximity switches for the combination without MDF

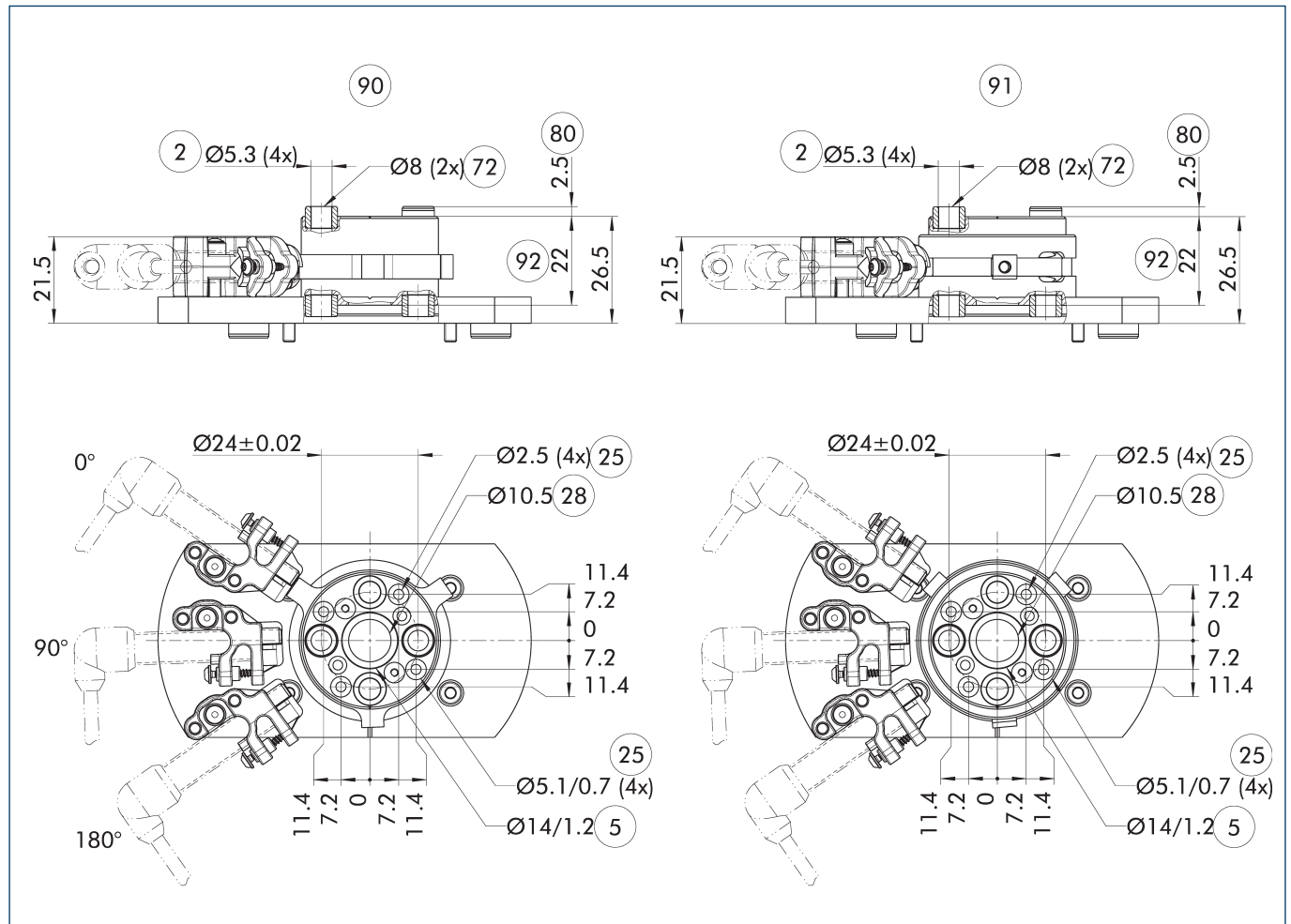

The drawing shows the option of using inductive proximity switches without the base module or other options for the swivel unit. With this option, up to three positions can be monitored with inductive sensors. Option SI offers adjustable monitoring positions, SF offers fixed positions.

- ② Attachment connection
- ⑤ O-ring
- ②⑤ Fluid feed-through
- ②⑧ Through-hole
- ⑦② Fit for centering sleeves
- ⑧①① Depth of the centering sleeve hole in the counter part
- ⑨① Inductive monitoring of fixed position (SF)
- ⑨① Inductive monitoring of adjustable position (SI)
- ⑨② Additional dimension of the attached module, option SI/SF

Description	Position monitoring is adjustable	Weight of the module without base unit
		[kg]
Option for inductive proximity switches		
SF 16		0.19
SI 16	yes	0.12

① This option can either be ordered as a mounting kit or as part of a configured version of the swivel unit. For the complete technical data of all the possible combination options, please configure the swivel unit at schunk.com. Please note that the above-mentioned data refer only to the option and not to the complete unit.

Main view option for inductive proximity switches for the combination with MDF

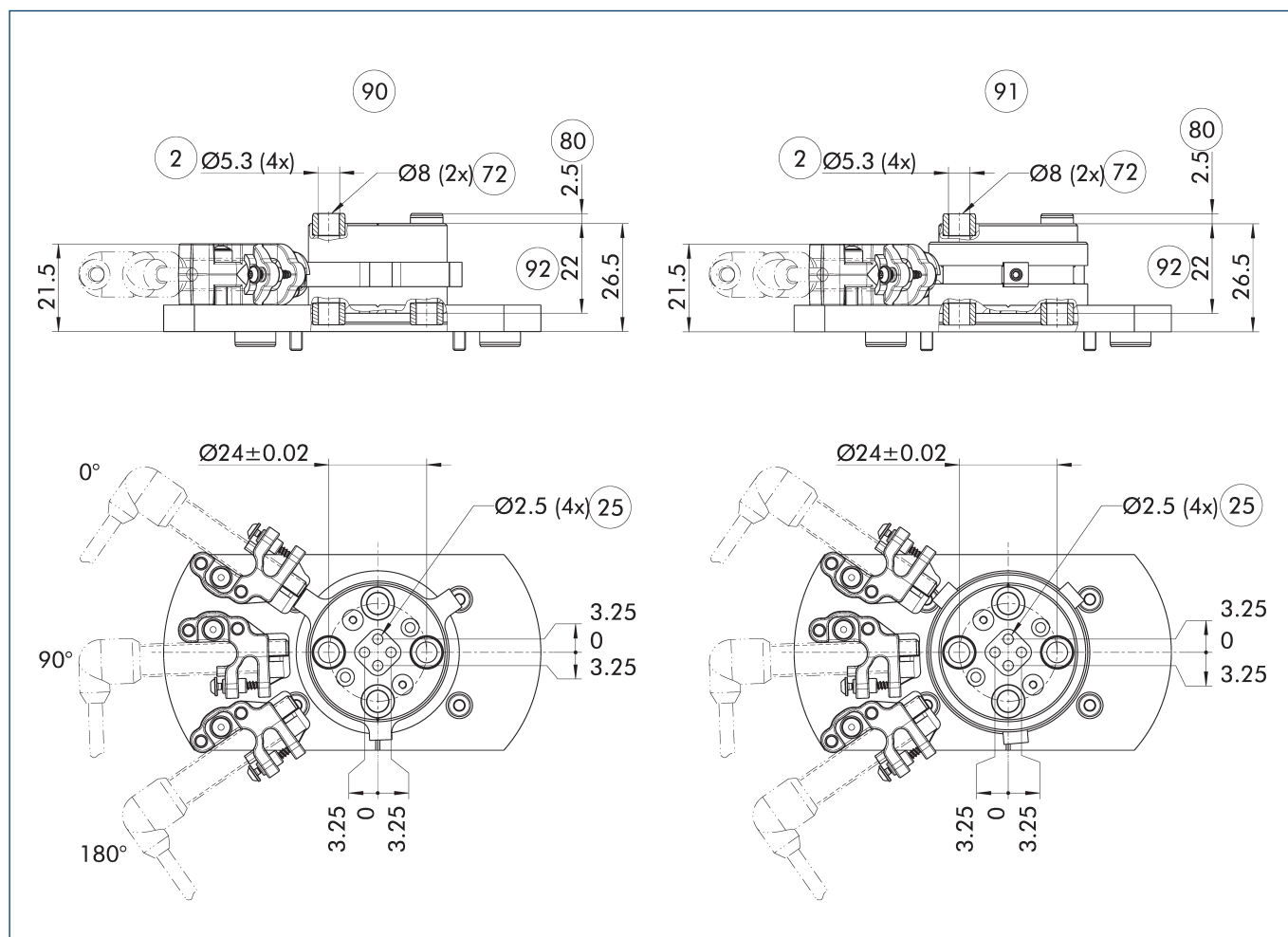

The drawing shows the option of using inductive proximity switches without the base module or other options for the swivel unit. With this option, up to three positions can be monitored with inductive sensors. Option SI offers adjustable monitoring positions, SF offers fixed positions.

- ② Attachment connection
- ②5 Fluid feed-through
- ⑦2 Fit for centering sleeves
- ⑧0 Depth of the centering sleeve hole in the counter part
- ⑨0 Inductive monitoring of fixed position (SF)
- ⑨1 Inductive monitoring of adjustable position (SI)
- ⑨2 Additional dimension of the attached module, option SI/SF

Description	Position monitoring is adjustable	Weight of the module without base unit [kg]
Option for inductive proximity switches		
SF 16 MDF		0.21
SI 16 MDF	yes	0.13

① This option can either be ordered as a mounting kit or as part of a configured version of the swivel unit. For the complete technical data of all the possible combination options, please configure the swivel unit at schunk.com. Please note that the above-mentioned data refer only to the option and not to the complete unit.

SRM 16

Universal swivel unit

Hose-free direct connection M3

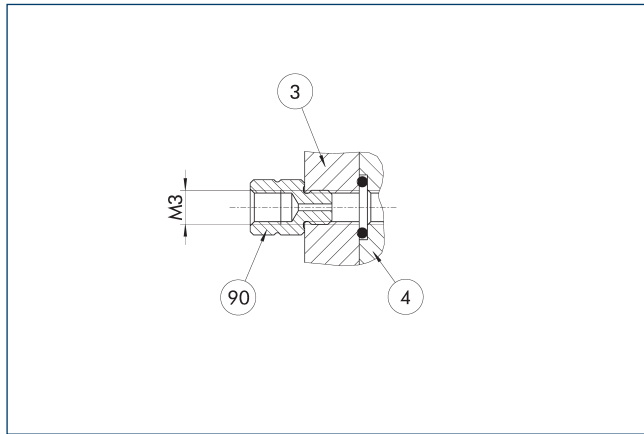

- ③ Adapter
- ④ Rotary unit
- ⑨⑩ Fixed throttle

The direct connection is used for compressed air supply without error-prone tubing. Instead, the pressure medium is fed through the bore-holes in the mounting plate. The required O-ring as well as the fixed throttle are enclosed to the product's accessory kit.

Large end position adjustability 90°

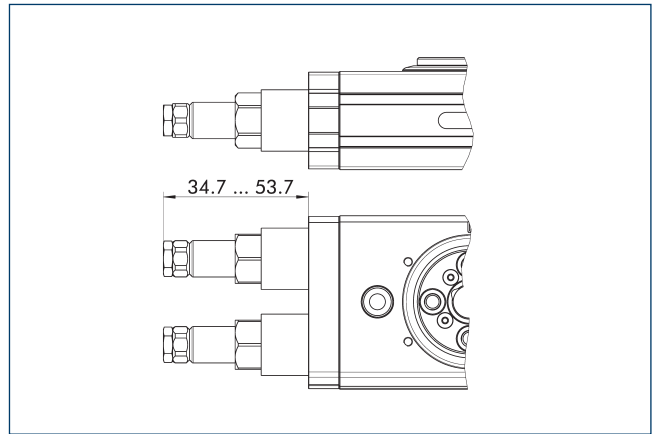

The drawing shows the change in dimension of the "large end position adjustability (90°)" option as compared to the basic variant. The option permits the end positions to be adjusted by up to 93°. More information can be found in the introduction to the series.

Adapter for SCHUNK gripper

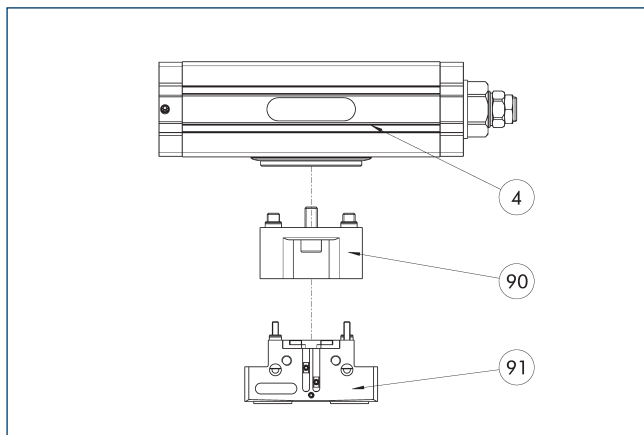

- ④ Rotary unit
- ⑨⑩ Adapter plate
- ⑨⑪ Grippers

Adapter plates are available for mounting many types of SCHUNK grippers. All combinations of swivel/gripping units, and associated adapter plates can be configured in the SCHUNK PARTCommunity and downloaded as a 3D model.

Pneumatic middle position (M)

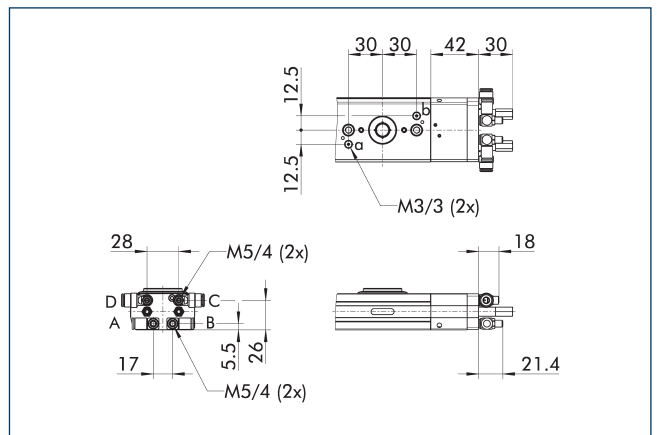

- A, a Main / direct connection, rotary actuator rotates clockwise
- B, b Main / direct connection, rotary actuator rotates counterclockwise
- C Main connection center position
- D Main connection center position

The drawing shows the change in dimension of the "pneumatic center position (M)" option compared to the basic variant. Heavy attachments may swing before they reach the final position.

IN 80 inductive proximity switches

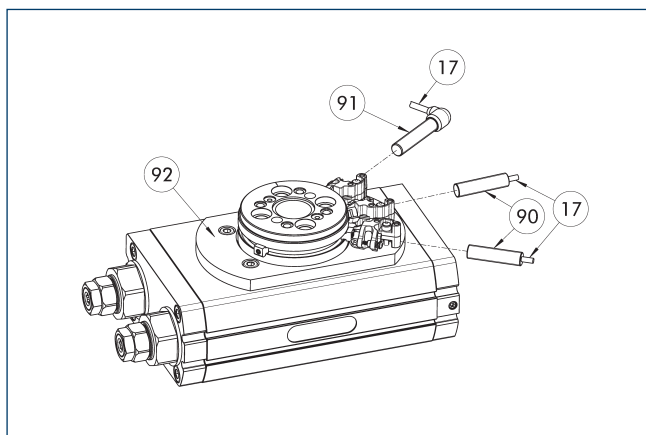

- ①7 Cable outlet
 ①90 Sensor IN ...
 ①91 Sensor IN...-SA
 ①92 Option SI/SF

End and intermediate position monitoring can be mounted with an attachment kit. Ordering note: When combining an SRM 16 with an MDF option, you will need the attachment kit with the abbreviation (4P).

Description	ID	Often combined
Attachment kit for proximity switch		
AS-NHS-SF-SRM 16	1483228	
AS-NHS-SF-SRM 16 (4P)	1496612	
AS-NHS-SI-SRM 16	1483226	
AS-NHS-SI-SRM 16 (4P)	1496586	
Inductive proximity switch		
IN 80-0-M12	0301588	
IN 80-0-M8	0301488	
IN 80-S-M12	0301578	
IN 80-S-M8	0301478	●
INK 80-0	0301551	
INK 80-S	0301550	
Inductive proximity switch with lateral cable outlet		
IN 80-S-M12-SA	0301587	
IN 80-S-M8-SA	0301483	●
INK 80-S-SA	0301566	

- ① Two or three sensors (closer/S) are required for each unit, as well as optional extension cables. Please consider the minimum permissible bending radii for sensor cables. These are generally 35 mm.

Electronic magnetic switch MMS

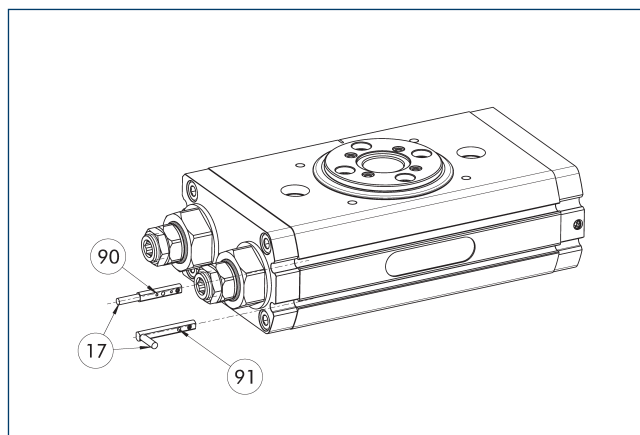

- ①7 Cable outlet
 ①90 Sensor MMS 22..
 ①91 Sensor MMS 22...-SA

End position monitoring for mounting in the C-slot.

Description	ID	Often combined
Electronic magnetic switch		
MMS 22-S-M8-PNP	0301032	●
MMSK 22-S-PNP	0301034	
Electronic magnetic switches with lateral cable outlet		
MMS 22-S-M8-PNP-SA	0301042	●
MMSK 22-S-PNP-SA	0301044	
Connection cables		
KA BG08-L 3P-0300-PNP	0301622	●
KA BG08-L 3P-0500-PNP	0301623	
KA BW08-L 3P-0300-PNP	0301594	
KA BW08-L 3P-0500-PNP	0301502	
Clip for connector/socket		
CLI-M8	0301463	
Cable extension		
KV BW08-SG08 3P-0030-PNP	0301495	
KV BW08-SG08 3P-0100-PNP	0301496	
KV BW08-SG08 3P-0200-PNP	0301497	●
Sensor distributor		
V2-M8	0301775	●
V4-M8	0301746	
V8-M8	0301751	

- ① Two sensors are required per unit for monitoring two positions. On option, extension cables and sensor distributors are available. Additional product variants of the sensor, and further information and technical data can be found in the catalog chapter sensor system.

Programmable magnetic switch MMS 22-PI1

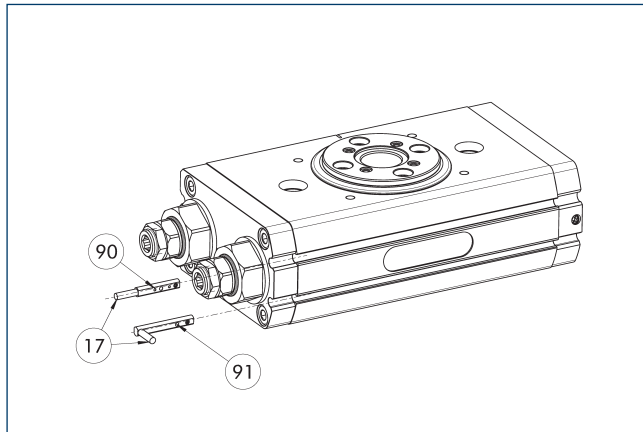

- 17 Cable outlet
- 90 Sensor MMS 22 PI1-...
- 91 Sensor MMS 22 ..-PI1-...-SA

Position monitoring with one programmable position per sensor and integrated electronic system in the sensor. Can be programmed using MT magnetic teaching tool (included in the scope of delivery, ID 0301030) or ST plug teaching tool (optional). End position monitoring for mounting in the C-slot. If the ST plug teaching tools are listed in the table provided, teaching is only possible with the ST teaching tools.

Description	ID	Often combined
Programmable magnetic switch		
MMS 22-PI1-S-M8-PNP	0301160	●
MMSK 22-PI1-S-PNP	0301162	
Programmable magnetic switch with lateral cable outlet		
MMS 22-PI1-S-M8-PNP-SA	0301166	●
MMSK 22-PI1-S-PNP-SA	0301168	
Programmable magnetic switch with stainless steel housing		
MMS 22-PI1-S-M8-PNP-HD	0301110	●
MMSK 22-PI1-S-PNP-HD	0301112	

- ① Two sensors are required per unit for monitoring two positions. On option, extension cables and sensor distributors are available. Additional product variants of the sensor, and further information and technical data can be found in the catalog chapter sensor system.

SRM 20

Universal swivel unit

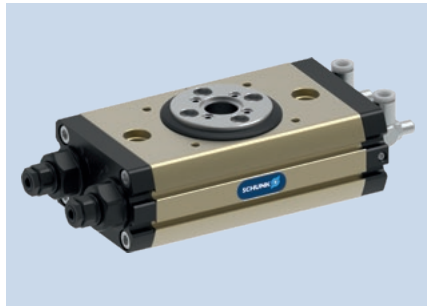

Dimensions and maximum loads

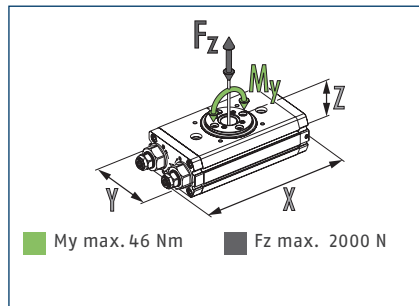

① The indicated moments and forces are static values, valid for the base unit, and may appear simultaneously. Throttling has to be done for ensuring that the rotary movement takes place without impact or bouncing. Otherwise the service life reduces.

Technical data SRM

Description	SRM 20-H-90-3	SRM 20-H-180-3	SRM 20-H-180-90
ID	1414867	1414866	1414868
End position damping	hydr. damper	hydr. damper	hydr. damper
Angle of rotation	[°] 90.0	180.0	180.0
End position adjustability	[°] +3/-3	+3/-3	+3/-93
Torque	[Nm] 3.6	3.6	3.6
Number of intermediate positions	none	none	none
IP protection class	65	65	65
Weight	[kg] 1.15	1.15	1.30
Fluid consumption (2x nom. angle)	[cm³] 24.0	45.0	45.0
Min./nom./max. operating pressure	[bar] 4/6/6.5	4/6/6.5	4/6/6.5
Diameter of connecting hose	6 x 3.9 x 1.05	6 x 3.9 x 1.05	6 x 3.9 x 1.05
Min./max. ambient temperature	[°C] 5/60	5/60	5/60
Cleanroom class ISO 14644-1:2015	5	5	5
Repeat accuracy	[°] 0.05	0.05	0.05
Diameter of center bore	[mm] 14.1	14.1	14.1
Max. permissible mass moment of inertia	[kgm²] 0.16	0.16	0.16
Dimensions X x Y x Z	[mm] 149.5 x 68.5 x 44.5	149.5 x 68.5 x 44.5	182 x 68.5 x 44.5
Options			
with media feed-through (MDF)	SRM 20-H-90-3-4P	SRM 20-H-180-3-4P	SRM 20-H-180-90-4P
ID	1414870	1414869	1414871
with electrical feed-throughs (EDF)	SRM 20-H-90-3-6E	SRM 20-H-180-3-6E	SRM 20-H-180-90-6E
ID	1414873	1414872	1414874
for inductive Sensors, adjustable (SI)	SRM 20-H-90-3-SI	SRM 20-H-180-3-SI	SRM 20-H-180-90-SI
ID	1414879	1414878	1414880
for inductive Sensors, fixed (SF)	SRM 20-H-90-3-SF	SRM 20-H-180-3-SF	SRM 20-H-180-90-SF
ID	1414891	1414890	1414892
with MDF and EDF	SRM 20-H-90-3-4P-6E	SRM 20-H-180-3-4P-6E	SRM 20-H-80-90-4P-6E
ID	1414876	1414875	1414877
with MDF and SI	SRM 20-H-90-3-4P-SI	SRM 20-H-180-3-4P-SI	SRM 20-H-180-90-4P-SI
ID	1414882	1414881	1414883
with MDF and SF	SRM 20-H-90-3-4P-SF	SRM 20-H-180-3-4P-SF	SRM 20-H-180-90-4P-SF
ID	1414894	1414893	1414895
with EDF and SI	SRM 20-H-90-3-6E-SI	SRM 20-H-180-3-6E-SI	SRM 20-H-180-90-6E-SI
ID	1414885	1414884	1414886
with EDF and SF	SRM 20-H-90-3-6E-SF	SRM 20-H-180-3-6E-SF	SRM 20-H-180-90-6E-SF
ID	1414897	1414896	1414898
with MDF, EDF and SI	SRM 20-H-90-3-4P-6E-SI	SRM 20-H-180-3-4P-6E-SI	SRM 20-H-180-90-4P-6E-SI
ID	1414888	1414887	1414889
with MDF, EDF and SF	SRM 20-H-90-3-4P-6E-SF	SRM 20-H-180-3-4P-6E-SF	SRM 20-H-180-90-4P-6E-SF
ID	1414900	1414899	1414901

① The complete or supplementary technical data of all possible combinations can be found in the catalog below or at schunk.com.

Max. permissible inertia J*

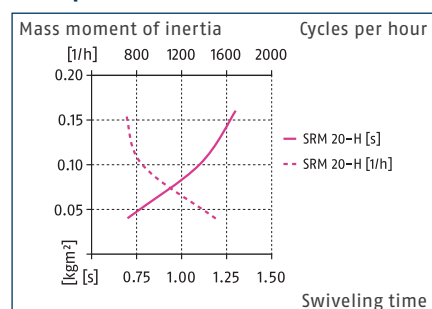

* *The diagrams are valid for basic units and for applications with a vertical swivel axis as well as for absolutely centric loads with a horizontal swivel axis and with an operating pressure of 6 bar. The swiveling times per throttling have to be observed, otherwise the life time may reduce. We will be happy to help you designing other applications. In addition, the SCHUNK Swiveling sizing assistant is available online.

Technical data SRM with center position

Description	SRM 20-H-180-3-M	SRM 20-H-180-90-M
ID	1490186	1490187
End position damping	hydr. damper	hydr. damper
Angle of rotation	[°] 180.0	180.0
End position adjustability	[°] +3/-3	+3/-93
Torque	[Nm] 3.6	3.6
Torque center position	[Nm] 2.3	2.3
Number of intermediate positions	1 x M (pneumatic)	1 x M (pneumatic)
Adjustability of middle position	[°] +3/-3	+3/-3
IP protection class	65	65
Weight	[kg] 1.50	1.65
Fluid consumption (2x nom. angle)	[cm³] 61.0	61.0
Min./nom./max. operating pressure	[bar] 4/6/6.5	4/6/6.5
Diameter of connecting hose	6 x 3.9 x 1.05	6 x 3.9 x 1.05
Diameter of connecting hose C/D	3 x 1.8 x 0.6	3 x 1.8 x 0.6
Min./max. ambient temperature	[°C] 5/60	5/60
Cleanroom class ISO 14644-1:2015	5	5
Repeat accuracy	[°] 0.05	0.05
Diameter of center bore	[mm] 14.1	14.1
Max. permissible mass moment of inertia	[kgm²] 0.054	0.054
Dimensions X x Y x Z	[mm] 220 x 68.5 x 44.5	220 x 68.5 x 44.5
Options		
with media feed-through (MDF)	SRM 20-H-180-3-M-4P	SRM 20-H-180-90-M-4P
ID	1490188	1490189
with electrical feed-throughs (EDF)	SRM 20-H-180-3-M-6E	SRM 20-H-180-90-M-6E
ID	1490220	1490221
for inductive Sensors, adjustable (SI)	SRM 20-H-180-3-M-SI	SRM 20-H-180-90-M-SI
ID	1490223	1490224
for inductive Sensors, fixed (SF)	SRM 20-H-180-3-M-SF	SRM 20-H-180-90-M-SF
ID	1490231	1490232
with MDF and EDF	SRM 20-H-180-3-M-4P-6E	SRM 20-H-180-90-M-4P-6E
ID	1490222	1490239
with MDF and SI	SRM 20-H-180-3-M-4P-SI	SRM 20-H-180-90-M-4P-SI
ID	1490225	1490226
with MDF and SF	SRM 20-H-180-3-M-4P-SF	SRM 20-H-180-90-M-4P-SF
ID	1490233	1490234
with EDF and SI	SRM 20-H-180-3-M-6E-SI	SRM 20-H-180-90-M-6E-SI
ID	1490227	1490228
with EDF and SF	SRM 20-H-180-3-M-6E-SF	SRM 20-H-180-90-M-6E-SF
ID	1490235	1490236
with MDF, EDF and SI	SRM 20-H-180-3-M-4P-6E-SI	SRM 20-H-180-90-M-4P-6E-SI
ID	1490229	1490230
with MDF, EDF and SF	SRM 20-H-180-3-M-4P-6E-SF	SRM 20-H-180-90-M-4P-6E-SF
ID	1490237	1490238

① The complete or supplementary technical data of all possible combinations can be found in the catalog below or at schunk.com.

Main view of basic version with hydraulic damping

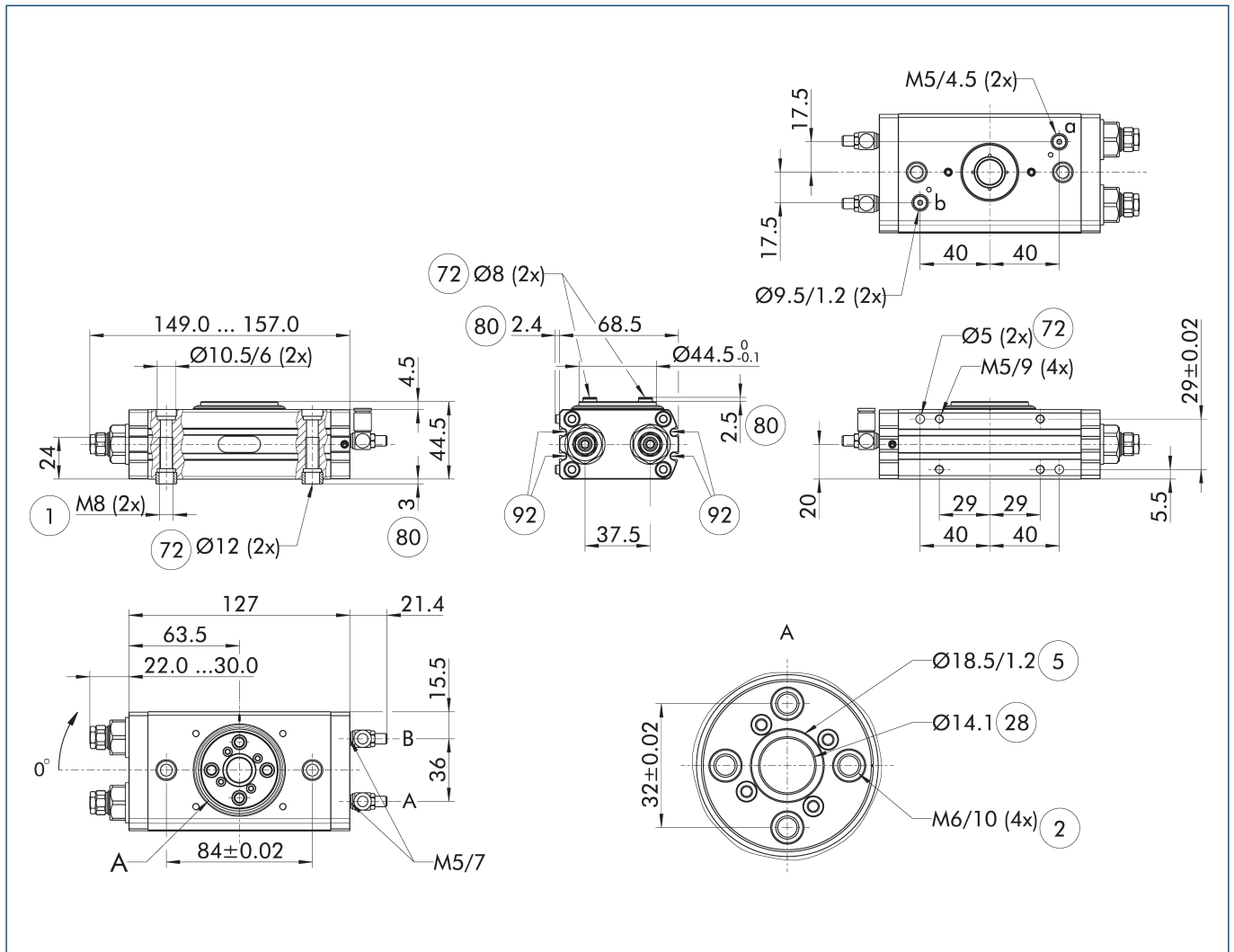

The drawing shows the unit in standard design, without considering any dimensions of the options described below.

① The SDV-P pressure maintenance valve can be used to maintain the position in the case of a loss of pressure (see "Accessories" catalog section).

A, a Main / direct connection, rotary actuator rotates clockwise

B, b Main / direct connection, rotary actuator rotates counterclockwise

① Connection swivel unit

② Attachment connection

⑤ O-ring

②⑧ Through-hole

⑦② Fit for centering sleeves

⑧①① Depth of the centering sleeve hole in the counter part

⑨② Sensor MMS 22..

Exemplary design

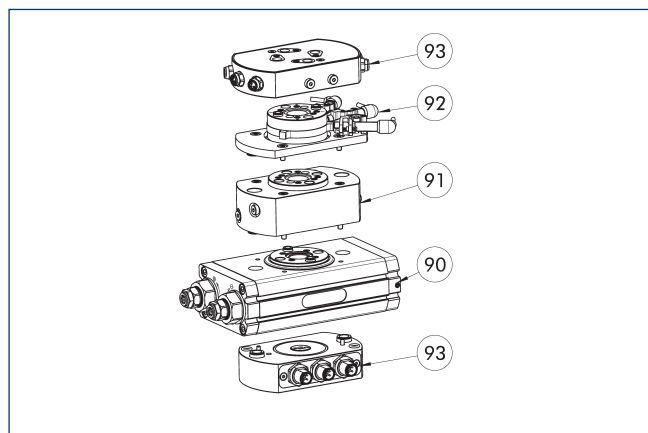

- ⑨⑩ SRM basis
- ⑨① Option MDF
- ⑨② Option SI
- ⑨③ Option EDF

The drawing shows an example of the SRM with the maximum possible number of optional modules. The SRM can be ordered as a basic version without optional modules, with each option individually, or as a combination of several optional modules. The unit is supplied fully assembled. The options cannot be ordered separately. You can find a list of the available combinations including IDs in the technical data table.

Total height

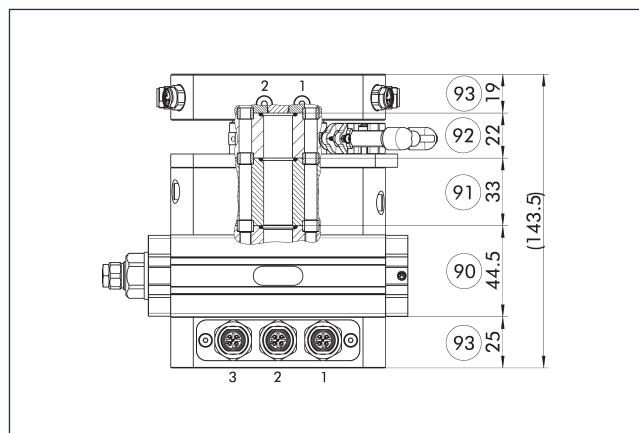

- ⑨⑩ Total height SRM basic version
- ⑨① Additional dimension of the attached module, option MDF
- ⑨② Additional dimension of the attached module, option SI/SF
- ⑨③ Additional dimension of the attached module, option EDF

The drawing shows the maximum additional dimension. Depending on the selected optional modules, the total height is reduced accordingly.

Main view option of media feed-through MDF

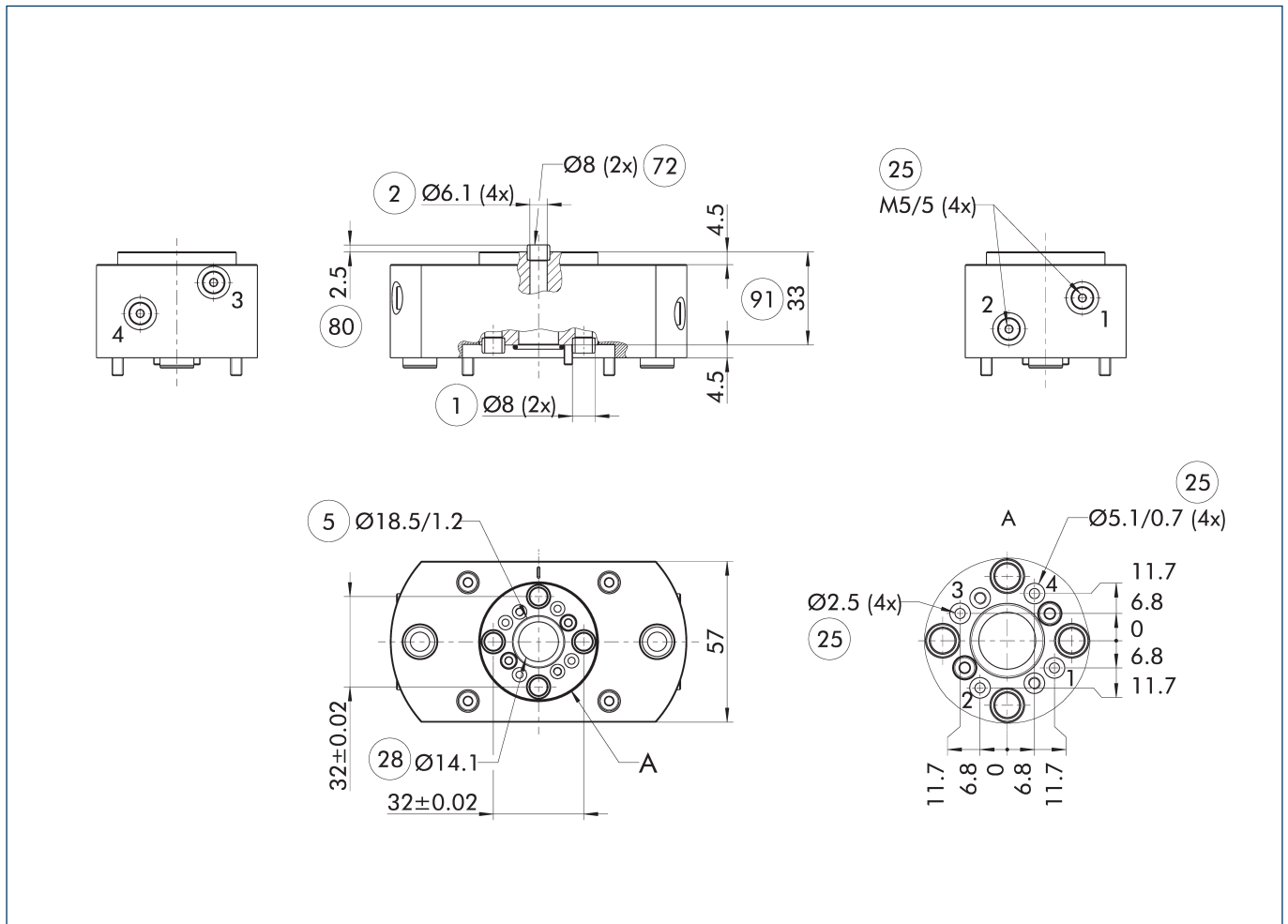

The drawing shows the option of media feed-through, without the base module or other options for the swivel unit.

- ① Connection swivel unit
- ② Attachment connection
- ③ Through-hole
- ④ Through-hole
- ⑤ O-ring
- ②⑤ Fluid feed-through
- ②⑧ Through-hole
- ⑦② Fit for centering sleeves
- ⑧① Depth of the centering sleeve hole in the counter part
- ⑨① Additional dimension of the attached module, option MDF

Reduction of torque at 6 bar in the fluid feed-through	Weight of the module without base unit	No. of fluid feed-throughs	Min. pressure in the fluid feed-through	Nominal pressure of fluid feed-through	Max. pressure fluid feed-through	Max. volumetric flow of feed-through (at 6 bar)
[Nm]	[kg]		[bar]	[bar]	[bar]	[l/min]
Option for media feed-through MDF						
- 1.5	0.45	4	-0.8	6	8	120

ⓘ This option cannot be ordered separately. It is a part of a configured version of the swivel unit. For the complete technical data of all the possible combination options, please configure the swivel unit at schunk.com. Please note that the above-mentioned data refer only to the option and not to the complete unit.

Main view option of electric rotary feed-through EDF

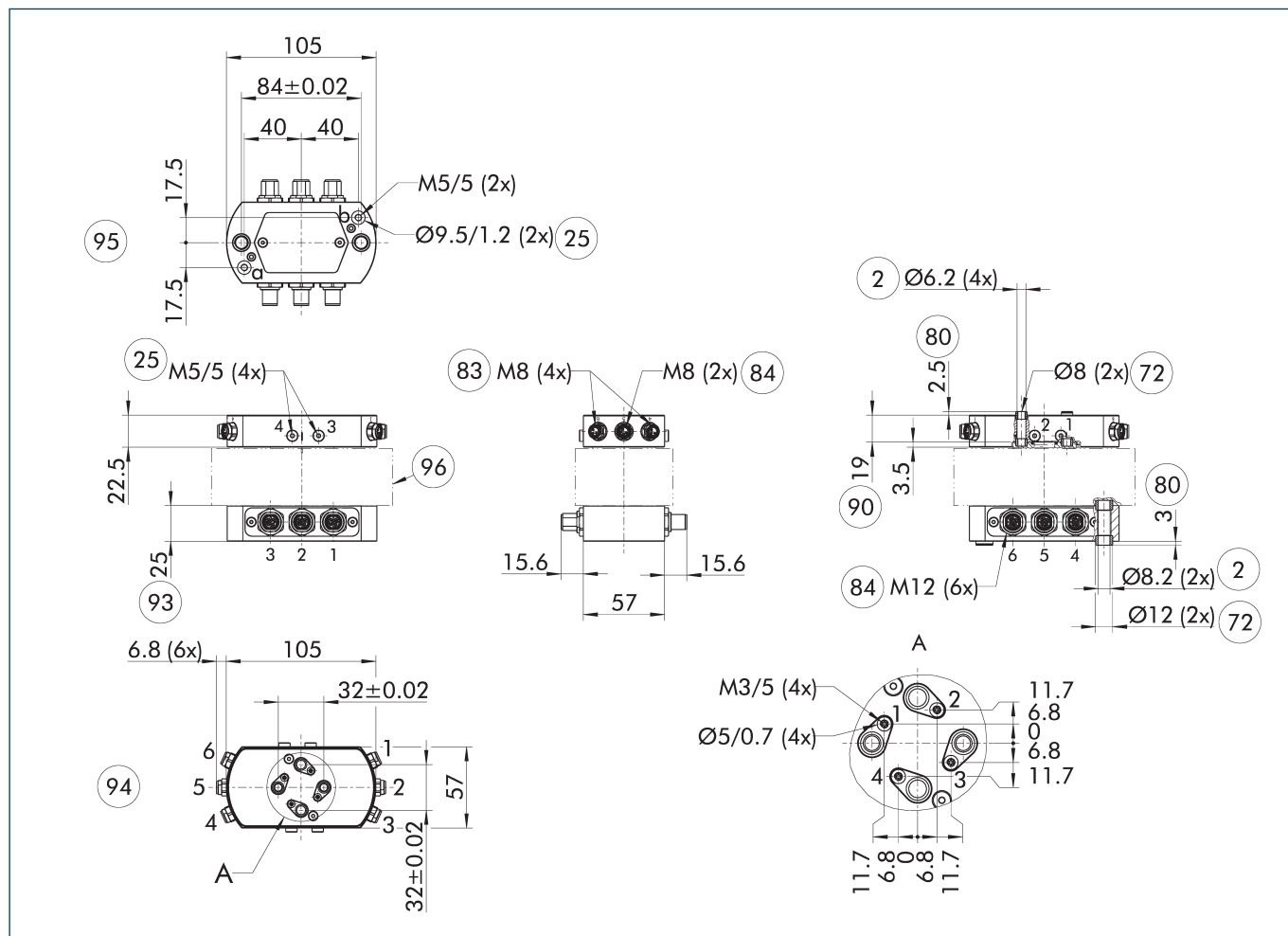

The drawing shows the option of an electric rotary feed-through without the base module or other options for the swivel unit.

- A, a Main / direct connection, rotary actuator rotates clockwise
- B, b Main / direct connection, rotary actuator rotates counterclockwise
- ② Attachment connection
- ②⑤ Fluid feed-through
- ⑦② Fit for centering sleeves
- ⑧① Depth of the centering sleeve hole in the counter part
- ⑧③ Input for 3 pole sensor feed-through
- ⑧④ Input for 4 pole sensor feed-through
- ⑨①① Additional dimension of the attached module, option EDF output side
- ⑨③③ Additional dimension of the attached module, option EDF drive side
- ⑨④④ EDF drive side hidden from view
- ⑨⑤⑤ EDF output side hidden from view
- ⑨⑥⑥ SRM basis and other options

Weight of the module without base unit	Size of the socket (output)	Size of the connector (drive)	Number of wires	Max. voltage	Max. current per wire	Max. ambient temperature
[kg]				[V]	[A]	[°C]
Optional electric rotary feed-through EDF						
0.52	4xM8/3-polig 2xM8/4-polig	6xM12/4-polig	20	48	1	60

① This option cannot be ordered separately. It is a part of a configured version of the swivel unit. For the complete technical data of all the possible combination options, please configure the swivel unit at schunk.com. Please note that the above-mentioned data refer only to the option and not to the complete unit.

SRM 20

Universal swivel unit

Main view option for inductive proximity switches

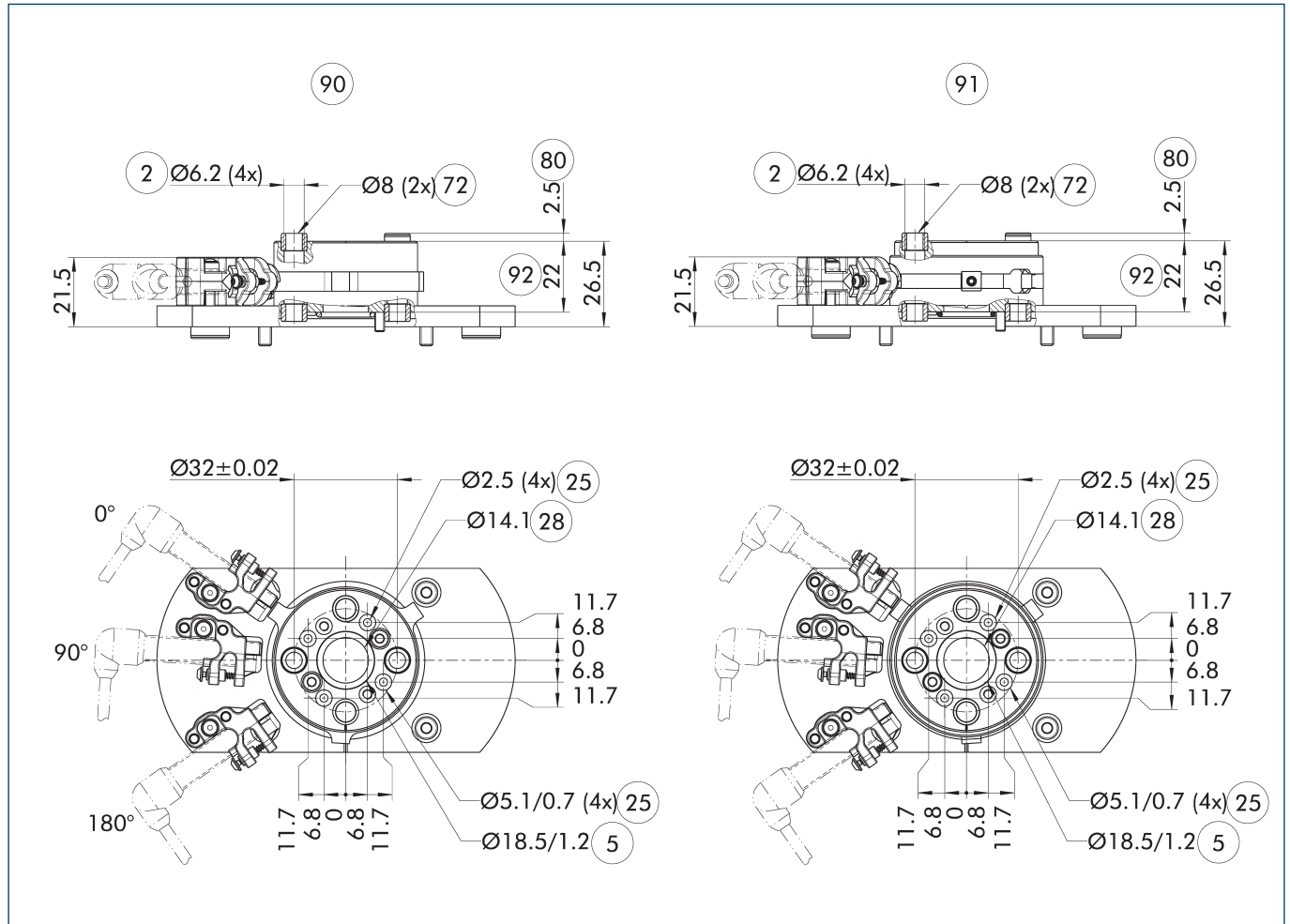

The drawing shows the option of using inductive proximity switches without the base module or other options for the swivel unit. With this option, up to three positions can be monitored with inductive sensors. Option SI offers adjustable monitoring positions, SF offers fixed positions.

- ② Attachment connection
- ⑤ O-ring
- ②⑤ Fluid feed-through
- ②⑧ Through-hole
- ⑦② Fit for centering sleeves
- ⑧② Depth of the centering sleeve hole in the counter part
- ⑨② Inductive monitoring of fixed position (SF)
- ⑨① Inductive monitoring of adjustable position (SI)
- ⑨② Additional dimension of the attached module, option SI/SF

Description	Position monitoring is adjustable	Weight of the module without base unit
		[kg]
Option for inductive proximity switches		
SF 20		0.31
SI 20	yes	0.17

① This option can either be ordered as a mounting kit or as part of a configured version of the swivel unit. For the complete technical data of all the possible combination options, please configure the swivel unit at schunk.com. Please note that the above-mentioned data refer only to the option and not to the complete unit.

Hose-free direct connection M5

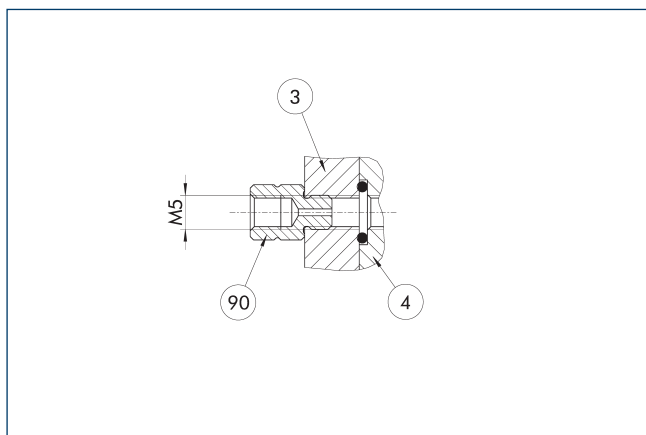

- ③ Adapter
- ④ Rotary unit
- ⑨⑩ Fixed throttle

The direct connection is used for compressed air supply without error-prone tubing. Instead, the pressure medium is fed through the bore-holes in the mounting plate. The required O-ring as well as the fixed throttle are enclosed to the product's accessory kit.

Large end position adjustability 90°

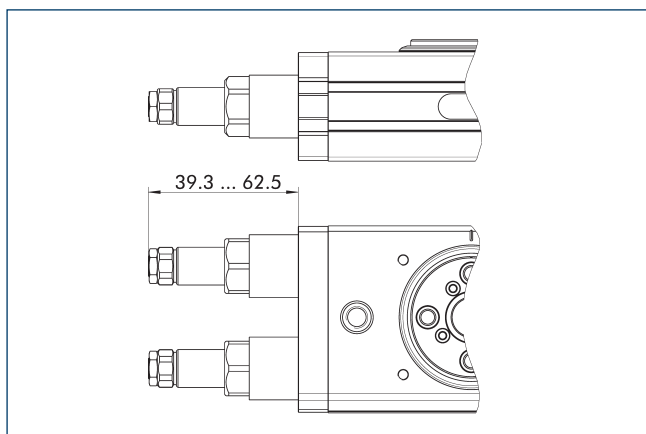

The drawing shows the change in dimension of the "large end position adjustability (90°)" option as compared to the basic variant. The option permits the end positions to be adjusted by up to 93°. More information can be found in the introduction to the series.

Adapter for SCHUNK gripper

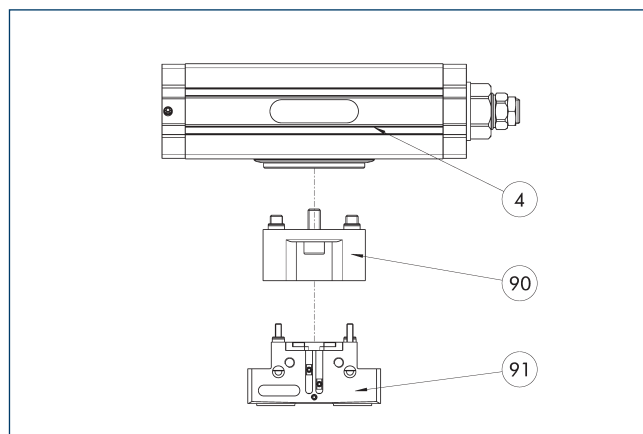

- ④ Rotary unit
- ⑨⑩ Adapter plate
- ⑨⑪ Grippers

Adapter plates are available for mounting many types of SCHUNK grippers. All combinations of swivel/gripping units, and associated adapter plates can be configured in the SCHUNK PARTCommunity and downloaded as a 3D model.

SRM 20

Universal swivel unit

Pneumatic middle position (M)

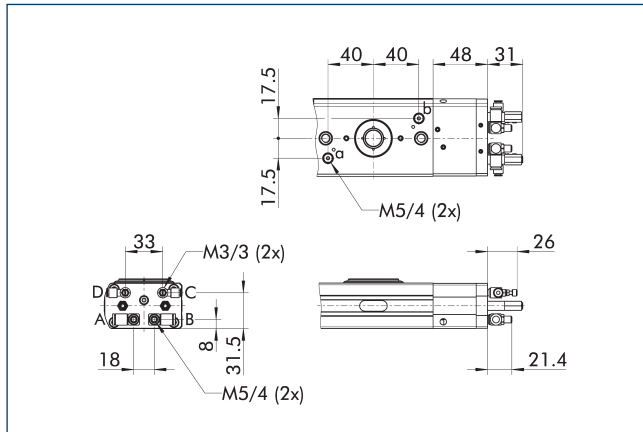

A, a Main / direct connection, rotary actuator rotates clockwise

B, b Main / direct connection, rotary actuator rotates counterclockwise

C Main connection center position

D Main connection center position

The drawing shows the change in dimension of the "pneumatic center position (M)" option compared to the basic variant. Heavy attachments may swing before they reach the final position.

IN 80 inductive proximity switches

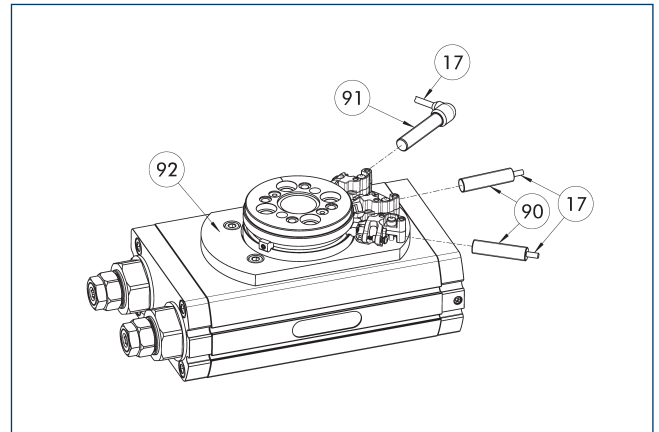

17 Cable outlet

90 Sensor IN ...

91 Sensor IN...-SA

92 Option SI/SF

End and intermediate position monitoring can be mounted with mounting kit

Description	ID	Often combined
Attachment kit for proximity switch		
AS-NHS-SF-SRM 20	1483230	
AS-NHS-SI-SRM 20	1483229	
Inductive proximity switch		
IN 80-0-M12	0301588	
IN 80-0-M8	0301488	
IN 80-S-M12	0301578	
IN 80-S-M8	0301478	●
INK 80-0	0301551	
INK 80-S	0301550	
Inductive proximity switch with lateral cable outlet		
IN 80-S-M12-SA	0301587	
IN 80-S-M8-SA	0301483	●
INK 80-S-SA	0301566	

① Two or three sensors (closer/S) are required for each unit, as well as optional extension cables. Please consider the minimum permissible bending radii for sensor cables. These are generally 35 mm.

Electronic magnetic switch MMS

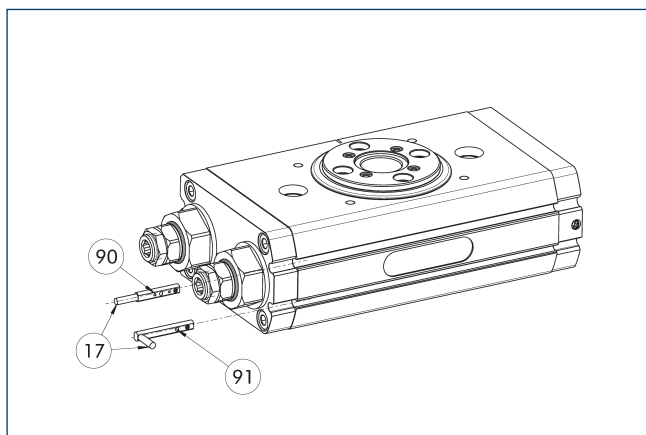

- ①7 Cable outlet
 ①90 Sensor MMS 22..
 ①91 Sensor MMS 22...-SA

End position monitoring for mounting in the C-slot.

Description	ID	Often combined
Electronic magnetic switch		
MMS 22-S-M8-PNP	0301032	●
MMSK 22-S-PNP	0301034	
Electronic magnetic switches with lateral cable outlet		
MMS 22-S-M8-PNP-SA	0301042	●
MMSK 22-S-PNP-SA	0301044	
Connection cables		
KA BG08-L 3P-0300-PNP	0301622	●
KA BG08-L 3P-0500-PNP	0301623	
KA BW08-L 3P-0300-PNP	0301594	
KA BW08-L 3P-0500-PNP	0301502	
Clip for connector/socket		
CLI-M8	0301463	
Cable extension		
KV BW08-SG08 3P-0030-PNP	0301495	
KV BW08-SG08 3P-0100-PNP	0301496	
KV BW08-SG08 3P-0200-PNP	0301497	●
Sensor distributor		
V2-M8	0301775	●
V4-M8	0301746	
V8-M8	0301751	

- ① Two sensors are required per unit for monitoring two positions. On option, extension cables and sensor distributors are available. Additional product variants of the sensor, and further information and technical data can be found in the catalog chapter sensor system.

Programmable magnetic switch MMS 22-PI1

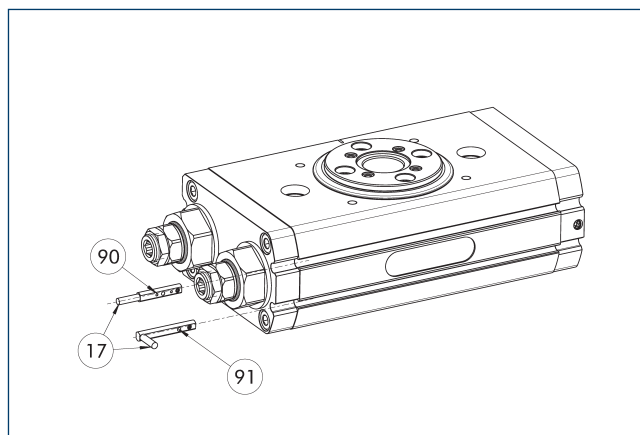

- ①7 Cable outlet
 ①90 Sensor MMS 22 PI1-...
 ①91 Sensor MMS 22 ..-PI1-...-SA

Position monitoring with one programmable position per sensor and integrated electronic system in the sensor. Can be programmed using MT magnetic teaching tool (included in the scope of delivery, ID 0301030) or ST plug teaching tool (optional). End position monitoring for mounting in the C-slot. If the ST plug teaching tools are listed in the table provided, teaching is only possible with the ST teaching tools.

Description	ID	Often combined
Programmable magnetic switch		
MMS 22-PI1-S-M8-PNP	0301160	●
MMSK 22-PI1-S-PNP	0301162	
Programmable magnetic switch with lateral cable outlet		
MMS 22-PI1-S-M8-PNP-SA	0301166	●
MMSK 22-PI1-S-PNP-SA	0301168	
Programmable magnetic switch with stainless steel housing		
MMS 22-PI1-S-M8-PNP-HD	0301110	●
MMSK 22-PI1-S-PNP-HD	0301112	

- ① Two sensors are required per unit for monitoring two positions. On option, extension cables and sensor distributors are available. Additional product variants of the sensor, and further information and technical data can be found in the catalog chapter sensor system.

Dimensions and maximum loads

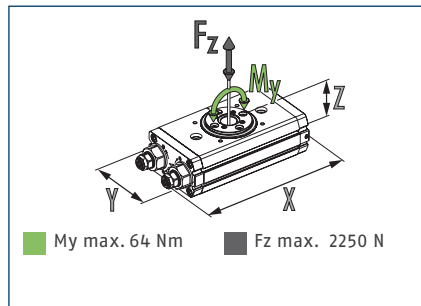
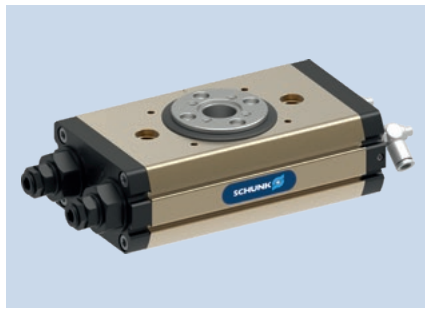

① The indicated moments and forces are static values, valid for the base unit, and may appear simultaneously. Throttling has to be done for ensuring that the rotary movement takes place without impact or bouncing. Otherwise the service life reduces.

Technical data SRM

Description	SRM 25-H-90-3	SRM 25-H-180-3	SRM 25-H-180-90
ID	1347287	1324471	1347317
End position damping	hydr. damper	hydr. damper	hydr. damper
Angle of rotation	[°] 90.0	180.0	180.0
End position adjustability	[°] +3/-3	+3/-3	+3/-93
Torque	[Nm] 5.95	5.95	5.95
Number of intermediate positions	none	none	none
IP protection class	65	65	65
Weight	[kg] 1.71	1.71	1.86
Fluid consumption (2x nom. angle)	[cm ³] 44.0	84.0	84.0
Min./nom./max. operating pressure	[bar] 4/6/6.5	4/6/6.5	4/6/6.5
Diameter of connecting hose	6 x 3.9 x 1.05	6 x 3.9 x 1.05	6 x 3.9 x 1.05
Min./max. ambient temperature	[°C] 5/60	5/60	5/60
Cleanroom class ISO 14644-1:2015	5	5	5
Repeat accuracy	[°] 0.07	0.07	0.07
Diameter of center bore	[mm] 17.1	17.1	17.1
Max. permissible mass moment of inertia	[kgm ²] 0.5	0.5	0.5
Dimensions X x Y x Z	[mm] 175 x 80 x 51	175 x 80 x 51	211 x 80 x 51
Options			
with media feed-through (MDF)	SRM 25-H-90-3-4P	SRM 25-H-180-3-4P	SRM 25-H-180-90-4P
ID	1347290	1324473	1347323
with electrical feed-throughs (EDF)	SRM 25-H-90-3-6E	SRM 25-H-180-3-6E	SRM 25-H-180-90-6E
ID	1347292	1328112	1347356
for inductive Sensors, adjustable (SI)	SRM 25-H-90-3-SI	SRM 25-H-180-3-SI	SRM 25-H-180-90-SI
ID	1347298	1347273	1347361
for inductive Sensors, fixed (SF)	SRM 25-H-90-3-SF	SRM 25-H-180-3-SF	SRM 25-H-180-90-SF
ID	1357504	1357466	1357487
with MDF and EDF	SRM 25-H-90-3-4P-6E	SRM 25-H-180-3-4P-6E	SRM 25-H-180-90-4P-6E
ID	1347296	1324474	1347358
with MDF and SI	SRM 25-H-90-3-4P-SI	SRM 25-H-180-3-4P-SI	SRM 25-H-180-90-4P-SI
ID	1347304	1347277	1347364
with MDF and SF	SRM 25-H-90-3-4P-SF	SRM 25-H-180-3-4P-SF	SRM 25-H-180-90-4P-SF
ID	1357506	1357469	1357495
with EDF and SI	SRM 25-H-90-3-6E-SI	SRM 25-H-180-3-6E-SI	SRM 25-H-180-90-6E-SI
ID	1347310	1347280	1347367
with EDF and SF	SRM 25-H-90-3-6E-SF	SRM 25-H-180-3-6E-SF	SRM 25-H-180-90-6E-SF
ID	1357510	1357475	1357498
with MDF, EDF and SI	SRM 25-H-90-3-4P-6E-SI	SRM 25-H-180-3-4P-6E-SI	SRM 25-H-180-90-4P-6E-SI
ID	1347312	1347283	1347372
with MDF, EDF and SF	SRM 25-H-90-3-4P-6E-SF	SRM 25-H-180-3-4P-6E-SF	SRM 25-H-180-90-4P-6E-SF
ID	1359583	1357481	1357499

① The complete or supplementary technical data of all possible combinations can be found in the catalog below or at schunk.com.

Max. permissible inertia J*

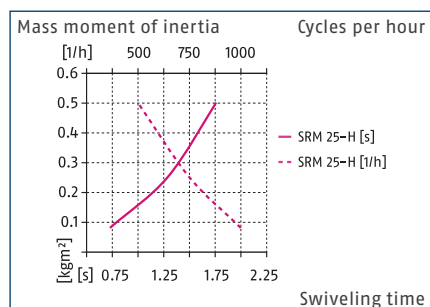

* The diagrams are valid for basic units and for applications with a vertical swivel axis as well as for absolutely centric loads with a horizontal swivel axis and with an operating pressure of 6 bar. The swiveling times per throttling have to be observed, otherwise the life time may reduce. We will be happy to help you designing other applications. In addition, the SCHUNK Swiveling sizing assistant is available online.

Technical data SRM with center position

Description	SRM 25-H-180-3-M	SRM 25-H-180-90-M
ID	1482210	1482211
End position damping	hydr. damper	hydr. damper
Angle of rotation	[°] 180.0	180.0
End position adjustability	[°] +3/-3	+3/-93
Torque	[Nm] 5.95	5.95
Torque center position	[Nm] 4.7	4.7
Number of intermediate positions	1 x M (pneumatic)	1 x M (pneumatic)
Adjustability of middle position	[°] +3/-3	+3/-3
IP protection class	65	65
Weight	[kg] 2.35	2.50
Fluid consumption (2x nom. angle)	[cm³] 100.0	100.0
Min./nom./max. operating pressure	[bar] 4/6/6.5	4/6/6.5
Diameter of connecting hose	6 x 3.9 x 1.05	6 x 3.9 x 1.05
Min./max. ambient temperature	[°C] 5/60	5/60
Cleanroom class ISO 14644-1:2015	5	5
Repeat accuracy	[°] 0.07	0.07
Diameter of center bore	[mm] 17.1	17.1
Max. permissible mass moment of inertia	[kgm²] 0.16	0.16
Dimensions X x Y x Z	[mm] 245 x 80 x 51	281 x 80 x 51
Options		
with media feed-through (MDF)	SRM 25-H-180-3-M-4P	SRM 25-H-180-90-M-4P
ID	1482212	1482213
with electrical feed-throughs (EDF)	SRM 25-H-180-3-M-6E	SRM 25-H-180-90-M-6E
ID	1482214	1482215
for inductive Sensors, adjustable (SI)	SRM 25-H-180-3-M-SI	SRM 25-H-180-90-M-SI
ID	1482218	1482219
for inductive Sensors, fixed (SF)	SRM 25-H-180-3-M-SF	SRM 25-H-180-90-M-SF
ID	1482226	1482227
with MDF and EDF	SRM 25-H-180-3-M-4P-6E	SRM 25-H-180-90-M-4P-6E
ID	1482216	1482217
with MDF and SI	SRM 25-H-180-3-M-4P-SI	SRM 25-H-180-90-M-4P-SI
ID	1482220	1482221
with MDF and SF	SRM 25-H-180-3-M-4P-SF	SRM 25-H-180-90-M-4P-SF
ID	1482228	1482229
with EDF and SI	SRM 25-H-180-3-M-6E-SI	SRM 25-H-180-90-M-6E-SI
ID	1482222	1482223
with EDF and SF	SRM 25-H-180-3-M-6E-SF	SRM 25-H-180-90-M-6E-SF
ID	1482230	1482231
with MDF, EDF and SI	SRM 25-H-180-3-M-4P-6E-SI	SRM 25-H-180-90-M-4P-6E-SI
ID	1482224	1482225
with MDF, EDF and SF	SRM 25-H-180-3-M-4P-6E-SF	SRM 25-H-180-90-M-4P-6E-SF
ID	1482232	1482233

① The complete or supplementary technical data of all possible combinations can be found in the catalog below or at schunk.com.

Main view of basic version with hydraulic damping

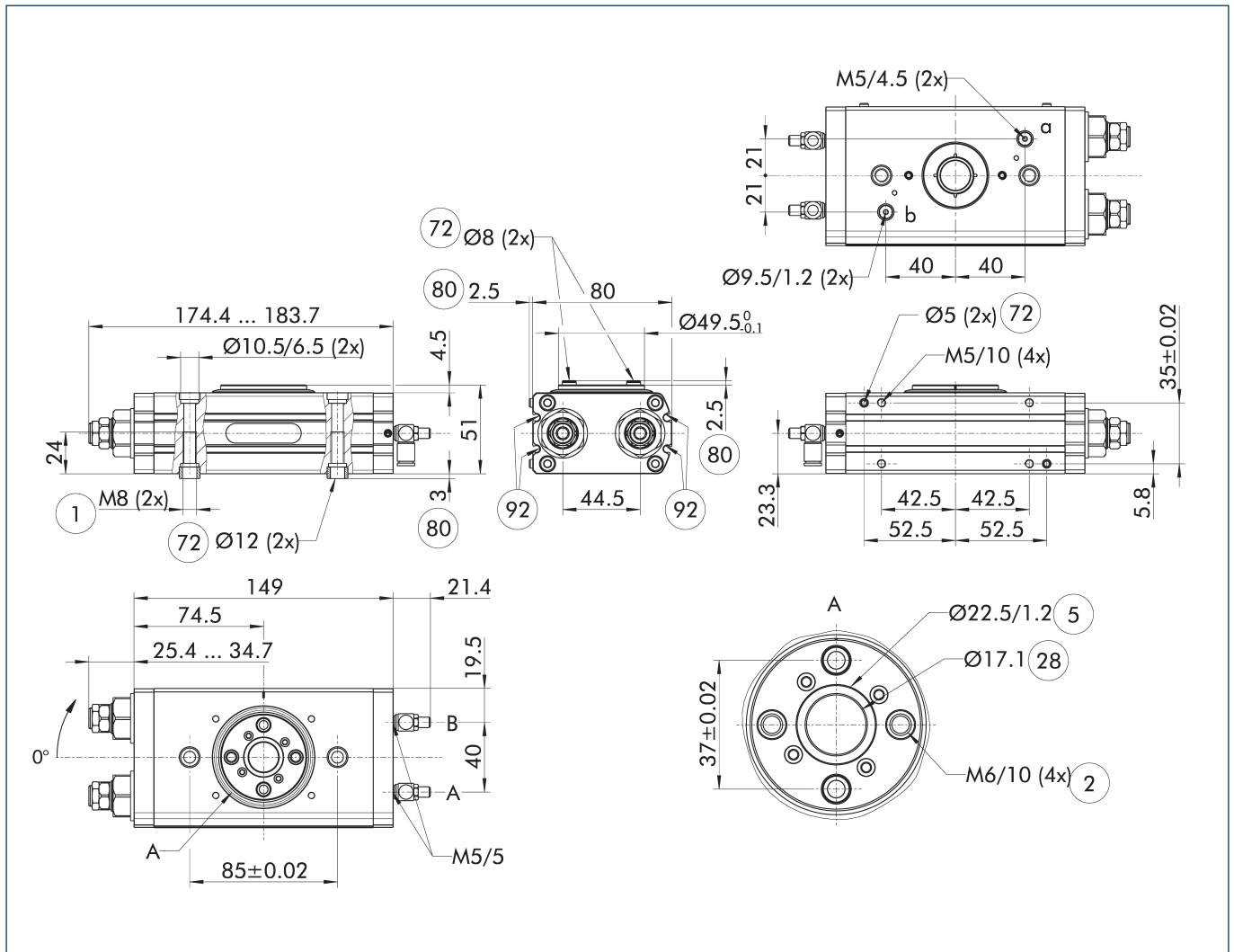

The drawing shows the unit in standard design, without considering any dimensions of the options described below.

① The SDV-P pressure maintenance valve can be used to maintain the position in the case of a loss of pressure (see "Accessories" catalog section).

A, a Main / direct connection, rotary actuator rotates clockwise

B, b Main / direct connection, rotary actuator rotates counterclockwise

① Connection swivel unit

② Attachment connection

⑤ O-ring

②⑧ Through-hole

⑦② Fit for centering sleeves

⑧①① Depth of the centering sleeve hole in the counter part

⑨② Sensor MMS 22..

Exemplary design

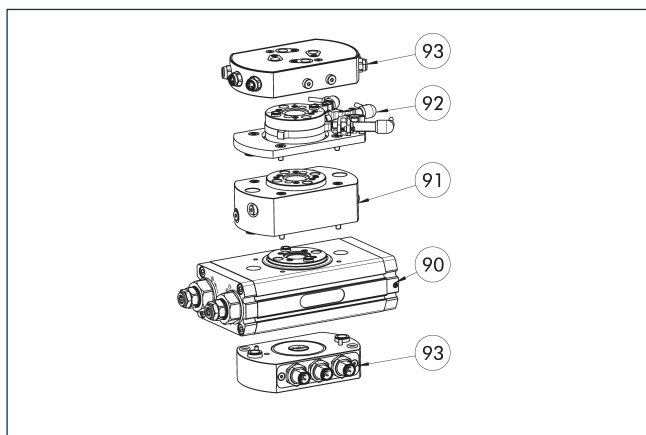

- ⑨⑩ SRM basis
- ⑨① Option MDF
- ⑨② Option SI
- ⑨③ Option EDF

The drawing shows an example of the SRM with the maximum possible number of optional modules. The SRM can be ordered as a basic version without optional modules, with each option individually, or as a combination of several optional modules. The unit is supplied fully assembled. The options cannot be ordered separately. You can find a list of the available combinations including IDs in the technical data table.

Total height

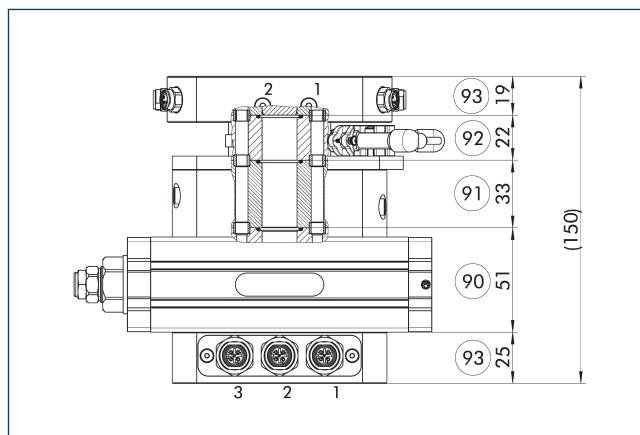

- ⑨⑩ Total height SRM basic version
- ⑨① Additional dimension of the attached module, option MDF
- ⑨② Additional dimension of the attached module, option SI/SF
- ⑨③ Additional dimension of the attached module, option EDF

The drawing shows the maximum additional dimension. Depending on the selected optional modules, the total height is reduced accordingly

Main view option of media feed-through MDF

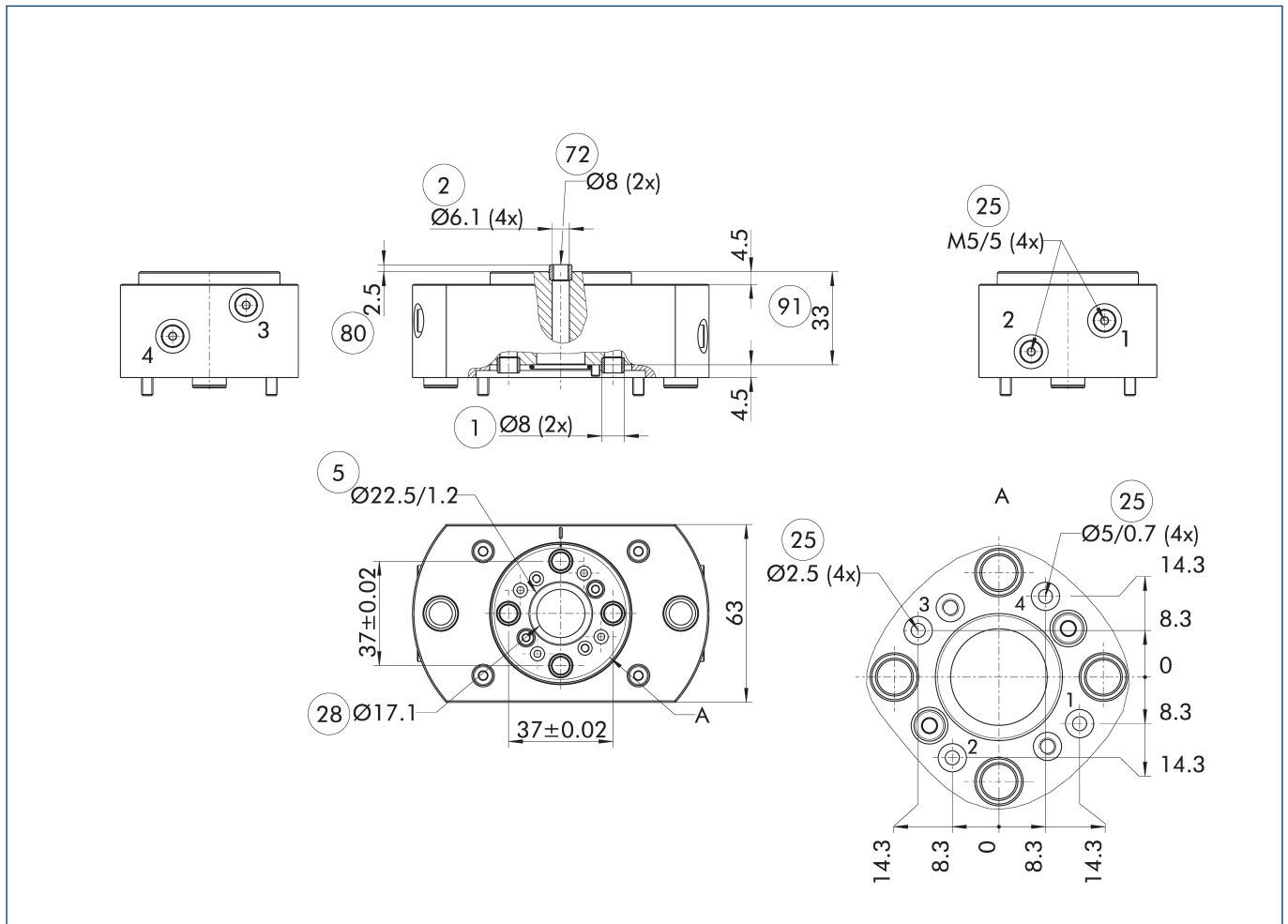

The drawing shows the option of media feed-through, without the base module or other options for the swivel unit.

- ① Connection swivel unit
- ② Attachment connection
- ⑤ O-ring
- ②⑤ Fluid feed-through
- ②⑧ Through-hole
- ⑦② Fit for centering sleeves
- ⑧① Depth of the centering sleeve hole in the counter part
- ⑨① Additional dimension of the attached module, option MDF

Reduction of torque at 6 bar in the fluid feed-through	Weight of the module without base unit	No. of fluid feed-throughs	Min. pressure in the fluid feed-through	Nominal pressure of fluid feed-through	Max. pressure fluid feed-through	Max. volumetric flow of feed-through (at 6 bar)	Diameter of center bore
[Nm]	[kg]		[bar]	[bar]	[bar]	[l/min]	[mm]
Option for media feed-through MDF							
- 1.95	0.85	4	-0.8	6	8	140	17.1

ⓘ This option cannot be ordered separately. It is a part of a configured version of the swivel unit. For the complete technical data of all the possible combination options, please configure the swivel unit at schunk.com. Please note that the above-mentioned data refer only to the option and not to the complete unit.

Main view option of electric rotary feed-through EDF

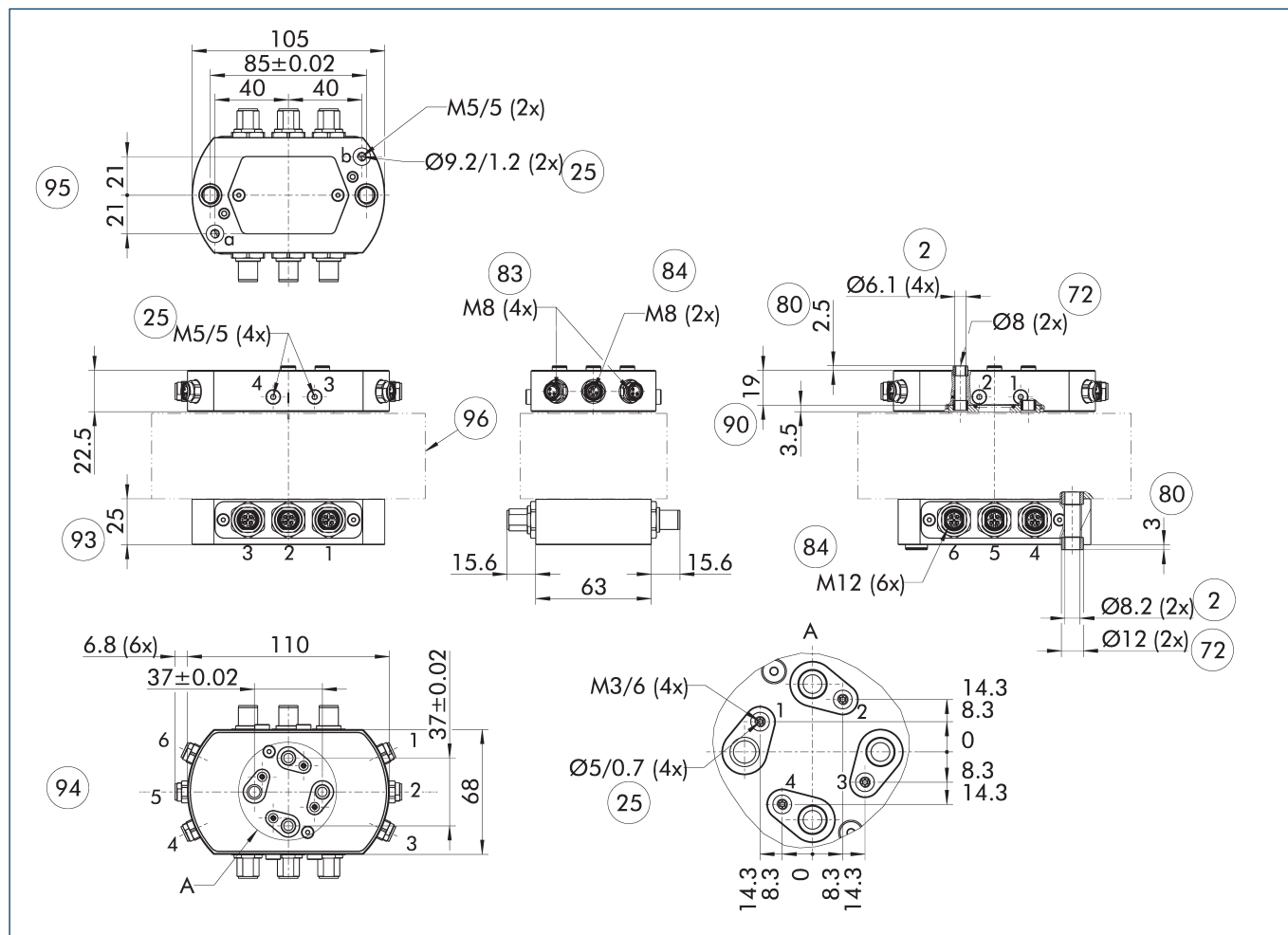

The drawing shows the option of an electric rotary feed-through without the base module or other options for the swivel unit.

- A, a Main / direct connection, rotary actuator rotates clockwise
- B, b Main / direct connection, rotary actuator rotates counterclockwise
- ② Attachment connection
- ②⑤ Fluid feed-through
- ⑦② Fit for centering sleeves
- ⑧① Depth of the centering sleeve hole in the counter part
- ⑧③ Input for 3 pole sensor feed-through
- ⑧④ Input for 4 pole sensor feed-through
- ⑨① Additional dimension of the attached module, option EDF output side
- ⑨③ Additional dimension of the attached module, option EDF drive side
- ⑨④ EDF drive side hidden from view
- ⑨⑤ EDF output side hidden from view
- ⑨⑥ SRM basis and other options

Weight of the module without base unit	Size of the socket (output)	Size of the connector (drive)	Number of wires	Max. voltage	Max. current per wire	Max. ambient temperature
[kg]				[V]	[A]	[°C]
Optional electric rotary feed-through EDF						
0.64	4xM8/3-polig 2xM8/4-polig	6xM12/4-polig	20	48	1	60

① This option cannot be ordered separately. It is a part of a configured version of the swivel unit. For the complete technical data of all the possible combination options, please configure the swivel unit at schunk.com. Please note that the above-mentioned data refer only to the option and not to the complete unit.

SRM 25

Universal swivel unit

Main view option for inductive proximity switches

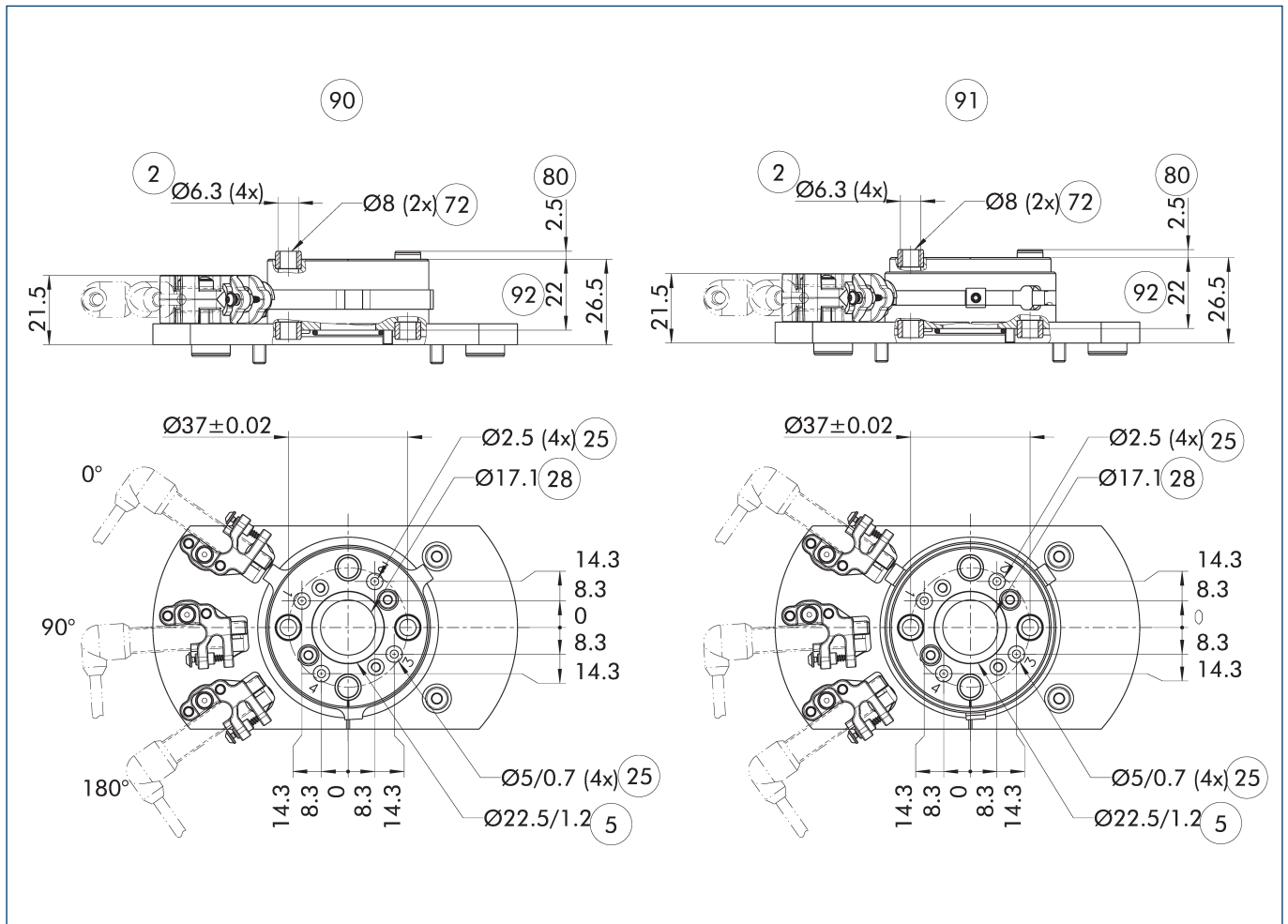

The drawing shows the option of using inductive proximity switches without the base module or other options for the swivel unit. With this option, up to three positions can be monitored with inductive sensors. Option SI offers adjustable monitoring positions, SF offers fixed positions.

- ② Attachment connection
- ⑤ O-ring
- ②⑤ Fluid feed-through
- ②⑧ Through-hole
- ⑦② Fit for centering sleeves
- ⑧①② Depth of the centering sleeve hole in the counter part
- ⑨① Inductive monitoring of fixed position (SF)
- ⑨① Inductive monitoring of adjustable position (SI)
- ⑨② Additional dimension of the attached module, option SI/SF

Description	Position monitoring is adjustable	Weight of the module without base unit
		[kg]
Option for inductive proximity switches		
SF 25		0.39
SI 25	yes	0.22

① This option can either be ordered as a mounting kit or as part of a configured version of the swivel unit. For the complete technical data of all the possible combination options, please configure the swivel unit at schunk.com. Please note that the above-mentioned data refer only to the option and not to the complete unit.

Hose-free direct connection M5

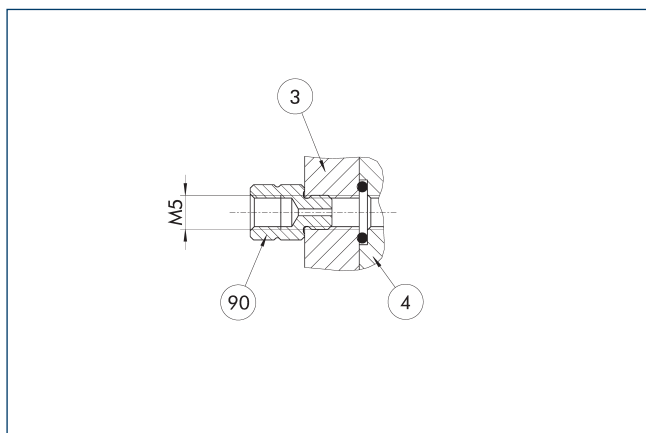

- ③ Adapter
- ④ Rotary unit
- ⑨⑩ Fixed throttle

The direct connection is used for compressed air supply without error-prone tubing. Instead, the pressure medium is fed through the bore-holes in the mounting plate. The required O-ring as well as the fixed throttle are enclosed to the product's accessory kit.

Large end position adjustability 90°

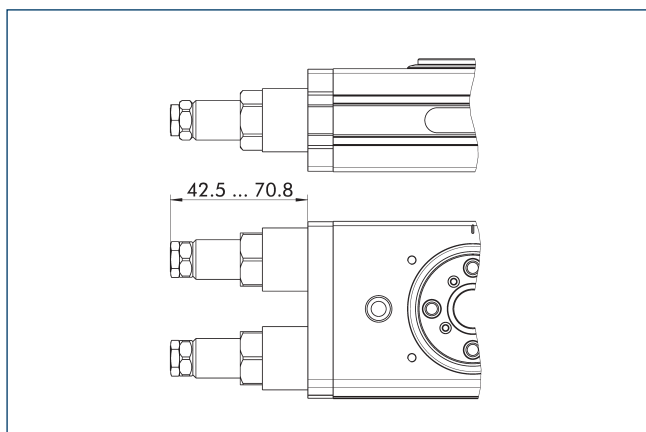

The drawing shows the change in dimension of the "large end position adjustability (90°)" option as compared to the basic variant. The option permits the end positions to be adjusted by up to 93°. More information can be found in the introduction to the series.

Adapter for SCHUNK gripper

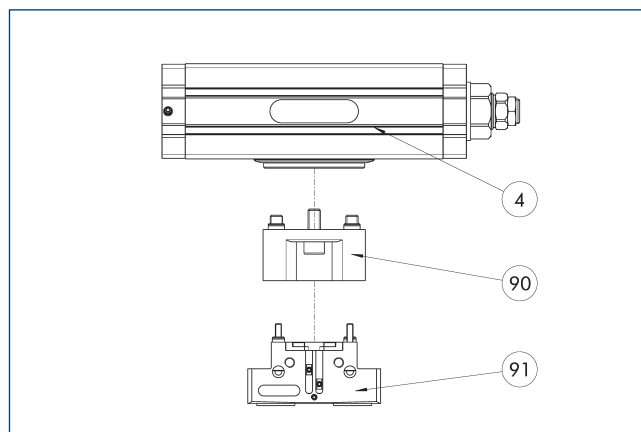

- ④ Rotary unit
- ⑨⑩ Adapter plate
- ⑨⑪ Grippers

Adapter plates are available for mounting many types of SCHUNK grippers. All combinations of swivel/gripping units, and associated adapter plates can be configured in the SCHUNK PARTCommunity and downloaded as a 3D model.

SRM 25

Universal swivel unit

Pneumatic middle position (M)

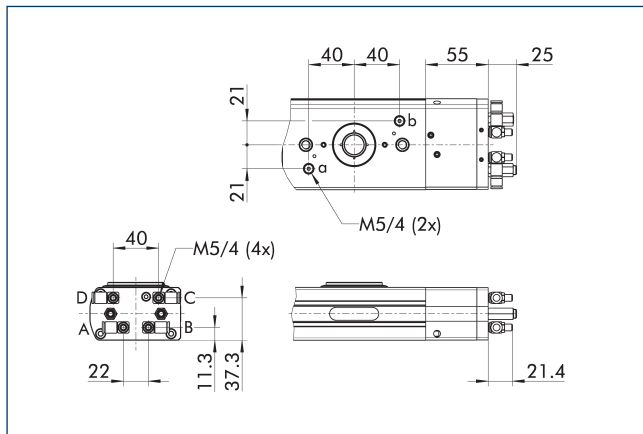

A, a Main / direct connection, rotary actuator rotates clockwise

C Main connection center position

B, b Main / direct connection, rotary actuator rotates counterclockwise

D Main connection center position

The drawing shows the change in dimension of the "pneumatic center position (M)" option compared to the basic variant. Heavy attachments may swing before they reach the final position.

IN 80 inductive proximity switches

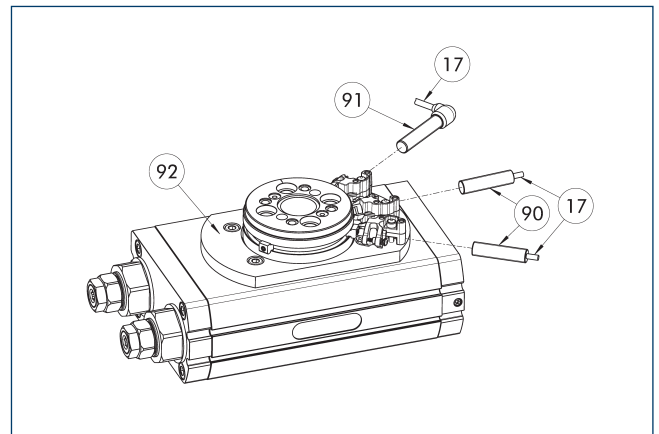

17 Cable outlet

91 Sensor IN...-SA

90 Sensor IN ...

92 Option SI/SF

End and intermediate position monitoring can be mounted with mounting kit

Description	ID	Often combined
Attachment kit for proximity switch		
AS-NHS-SF-SRM 25	1483234	
AS-NHS-SI-SRM 25	1483232	
Inductive proximity switch		
IN 80-0-M12	0301588	
IN 80-0-M8	0301488	
IN 80-S-M12	0301578	
IN 80-S-M8	0301478	●
INK 80-0	0301551	
INK 80-S	0301550	
Inductive proximity switch with lateral cable outlet		
IN 80-S-M12-SA	0301587	
IN 80-S-M8-SA	0301483	●
INK 80-S-SA	0301566	

① Two or three sensors (closer/S) are required for each unit, as well as optional extension cables. Please consider the minimum permissible bending radii for sensor cables. These are generally 35 mm.

Electronic magnetic switch MMS

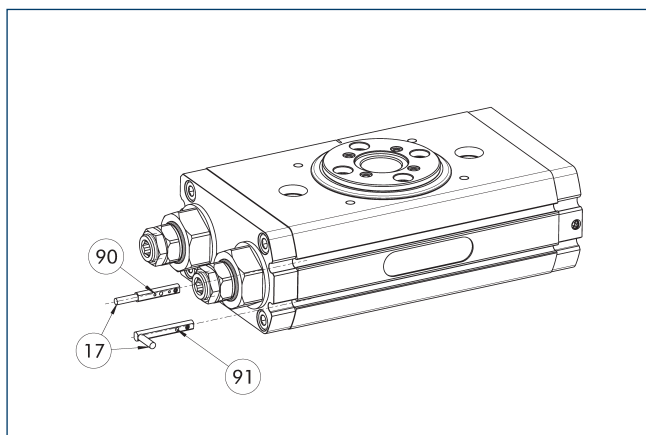

- ①7 Cable outlet
 ①90 Sensor MMS 22..
 ①91 Sensor MMS 22...-SA

End position monitoring for mounting in the C-slot.

Description	ID	Often combined
Electronic magnetic switch		
MMS 22-S-M8-PNP	0301032	●
MMSK 22-S-PNP	0301034	
Electronic magnetic switches with lateral cable outlet		
MMS 22-S-M8-PNP-SA	0301042	●
MMSK 22-S-PNP-SA	0301044	
Connection cables		
KA BG08-L 3P-0300-PNP	0301622	●
KA BG08-L 3P-0500-PNP	0301623	
KA BW08-L 3P-0300-PNP	0301594	
KA BW08-L 3P-0500-PNP	0301502	
Clip for connector/socket		
CLI-M8	0301463	
Cable extension		
KV BW08-SG08 3P-0030-PNP	0301495	
KV BW08-SG08 3P-0100-PNP	0301496	
KV BW08-SG08 3P-0200-PNP	0301497	●
Sensor distributor		
V2-M8	0301775	●
V4-M8	0301746	
V8-M8	0301751	

- ① Two sensors are required per unit for monitoring two positions. On option, extension cables and sensor distributors are available. Additional product variants of the sensor, and further information and technical data can be found in the catalog chapter sensor system.

Programmable magnetic switch MMS 22-PI1

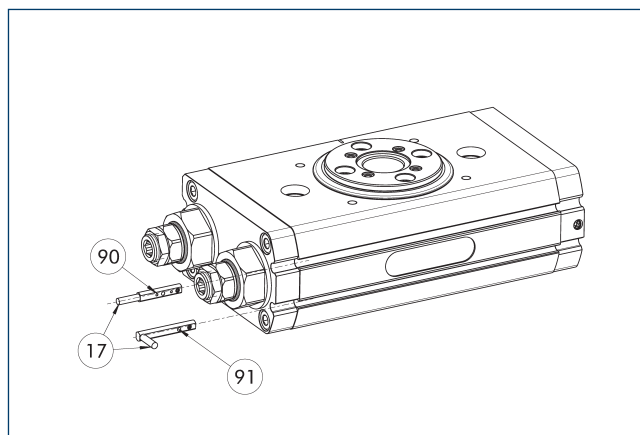

- ①7 Cable outlet
 ①90 Sensor MMS 22 PI1-...
 ①91 Sensor MMS 22 ..-PI1-...-SA

Position monitoring with one programmable position per sensor and integrated electronic system in the sensor. Can be programmed using MT magnetic teaching tool (included in the scope of delivery, ID 0301030) or ST plug teaching tool (optional). End position monitoring for mounting in the C-slot. If the ST plug teaching tools are listed in the table provided, teaching is only possible with the ST teaching tools.

Description	ID	Often combined
Programmable magnetic switch		
MMS 22-PI1-S-M8-PNP	0301160	●
MMSK 22-PI1-S-PNP	0301162	
Programmable magnetic switch with lateral cable outlet		
MMS 22-PI1-S-M8-PNP-SA	0301166	●
MMSK 22-PI1-S-PNP-SA	0301168	
Programmable magnetic switch with stainless steel housing		
MMS 22-PI1-S-M8-PNP-HD	0301110	●
MMSK 22-PI1-S-PNP-HD	0301112	

- ① Two sensors are required per unit for monitoring two positions. On option, extension cables and sensor distributors are available. Additional product variants of the sensor, and further information and technical data can be found in the catalog chapter sensor system.

SRM 32

Universal swivel unit



Dimensions and maximum loads

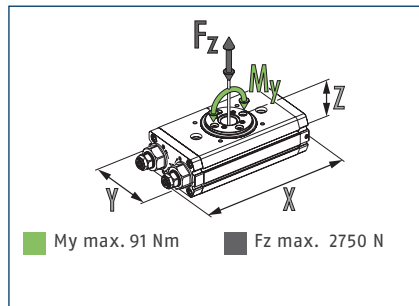

① The indicated moments and forces are static values, valid for the base unit, and may appear simultaneously. Throttling has to be done for ensuring that the rotary movement takes place without impact or bouncing. Otherwise the service life reduces.

Technical data SRM

Description	SRM 32-H-90-3	SRM 32-H-180-3	SRM 32-H-180-90
ID	1398197	1331295	1398230
End position damping	hydr. damper	hydr. damper	hydr. damper
Angle of rotation	[°] 90.0	180.0	180.0
End position adjustability	[°] +3/-3	+3/-3	+3/-93
Torque	[Nm] 12.0	12.0	12.0
Number of intermediate positions	none	none	none
IP protection class	65	65	65
Weight	[kg] 3.16	3.16	3.48
Fluid consumption (2x nom. angle)	[cm ³] 90.0	165.0	165.0
Min./nom./max. operating pressure	[bar] 4/6/6.5	4/6/6.5	4/6/6.5
Diameter of connecting hose	8 x 6 x 1	8 x 6 x 1	8 x 6 x 1
Min./max. ambient temperature	[°C] 5/60	5/60	5/60
Cleanroom class ISO 14644-1:2015	5	5	5
Repeat accuracy	[°] 0.05	0.05	0.05
Diameter of center bore	[mm] 21.1	21.1	21.1
Max. permissible mass moment of inertia	[kgm ²] 1.5	1.5	1.5
Dimensions X x Y x Z	[mm] 204.2 x 100 x 60	204.2 x 100 x 60	249.7 x 100 x 60
Options			
with media feed-through (MDF)	SRM 32-H-90-3-4P	SRM 32-H-180-3-4P	SRM 32-H-180-90-4P
ID	1398198	1331296	1398231
with electrical feed-throughs (EDF)	SRM 32-H-90-3-6E	SRM 32-H-180-3-6E	SRM 32-H-180-90-6E
ID	1398199	1331299	1398232
for inductive Sensors, adjustable (SI)	SRM 32-H-90-3-SI	SRM 32-H-180-3-SI	SRM 32-H-180-90-SI
ID	1398209	1398190	1398201
for inductive Sensors, fixed (SF)	SRM 32-H-90-3-SF	SRM 32-H-180-3-SF	SRM 32-H-180-90-SF
ID	1398214	1398193	1398205
with MDF and EDF	SRM 32-H-90-3-4P-6E	SRM 32-H-180-3-4P-6E	SRM 32-H-180-90-4P-6E
ID	1398200	1331300	1398233
with MDF and SI	SRM 32-H-90-3-4P-SI	SRM 32-H-180-3-4P-SI	SRM 32-H-180-90-4P-SI
ID	1398210	1398191	1398202
with MDF and SF	SRM 32-H-90-3-4P-SF	SRM 32-H-180-3-4P-SF	SRM 32-H-180-90-4P-SF
ID	1398215	1398194	1398206
with EDF and SI	SRM 32-H-90-3-6E-SI	SRM 32-H-180-3-6E-SI	SRM 32-H-180-90-6E-SI
ID	1398211	1398192	1398203
with EDF and SF	SRM 32-H-90-3-6E-SF	SRM 32-H-180-3-6E-SF	SRM 32-H-180-90-6E-SF
ID	1398216	1398195	1398207
with MDF, EDF and SI	SRM 32-H-90-3-4P-6E-SI	SRM 32-H-180-3-4P-6E-SI	SRM 32-H-180-90-4P-6E-SI
ID	1398213	1380217	1398204
with MDF, EDF and SF	SRM 32-H-90-3-4P-6E-SF	SRM 32-H-180-3-4P-6E-SF	SRM 32-H-180-90-4P-6E-SF
ID	1398217	1398196	1398208

① The complete or supplementary technical data of all possible combinations can be found in the catalog below or at schunk.com.

Max. permissible inertia J*

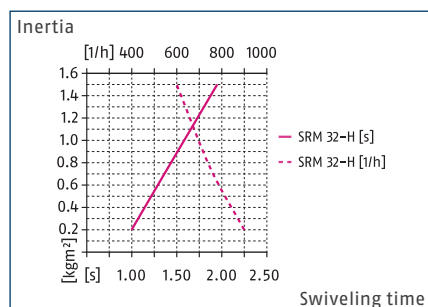

* The diagrams are valid for basic units and for applications with a vertical swivel axis as well as for absolutely centric loads with a horizontal swivel axis and with an operating pressure of 6 bar. The swiveling times per throttling have to be observed, otherwise the life time may reduce. We will be happy to help you designing other applications. In addition, the SCHUNK Swiveling sizing assistant is available online.

Technical data SRM with center position

Description	SRM 32-H-180-3-M	SRM 32-H-180-90-M
ID	1500680	1500681
End position damping	hydr. damper	hydr. damper
Angle of rotation	[°] 180.0	180.0
End position adjustability	[°] +3/-3	+3/-93
Torque	[Nm] 12.0	12.0
Torque center position	[Nm] 7.0	7.0
Number of intermediate positions	1 x M (pneumatic)	1 x M (pneumatic)
Adjustability of middle position	[°] +3/-3	+3/-3
IP protection class	65	65
Weight	[kg] 3.90	4.20
Fluid consumption (2x nom. angle)	[cm³] 195.0	195.0
Min./nom./max. operating pressure	[bar] 4/6/6.5	4/6/6.5
Diameter of connecting hose	6 x 3.9 x 1.05	6 x 3.9 x 1.05
Min./max. ambient temperature	[°C] 5/60	5/60
Cleanroom class ISO 14644-1:2015	5	5
Repeat accuracy	[°] 0.05	0.05
Diameter of center bore	[mm] 21.1	21.1
Max. permissible mass moment of inertia	[kgm²] 0.4	0.4
Dimensions X x Y x Z	[mm] 280 x 100 x 60	325 x 100 x 60
Options		
with media feed-through (MDF)	SRM 32-H-180-3-M-4P	SRM 32-H-180-90-M-4P
ID	1500682	1500683
with electrical feed-throughs (EDF)	SRM 32-H-180-3-M-6E	SRM 32-H-180-90-M-6E
ID	1500684	1500685
for inductive Sensors, adjustable (SI)	SRM 32-H-180-3-M-SI	SRM 32-H-180-90-M-SI
ID	1500688	1500689
for inductive Sensors, fixed (SF)	SRM 32-H-180-3-M-SF	SRM 32-H-180-90-M-SF
ID	1500696	1500697
with MDF and EDF	SRM 32-H-180-3-M-4P-6E	SRM 32-H-180-90-M-4P-6E
ID	1500686	1500687
with MDF and SI	SRM 32-H-180-3-M-4P-SI	SRM 32-H-180-90-M-4P-SI
ID	1500690	1500691
with MDF and SF	SRM 32-H-180-3-M-4P-SF	SRM 32-H-180-90-M-4P-SF
ID	1500698	1500699
with EDF and SI	SRM 32-H-180-3-M-6E-SI	SRM 32-H-180-90-M-6E-SI
ID	1500692	1500693
with EDF and SF	SRM 32-H-180-3-M-6E-SF	SRM 32-H-180-90-M-6E-SF
ID	1500700	1500701
with MDF, EDF and SI	SRM 32-H-180-3-M-4P-6E-SI	SRM 32-H-180-90-M-4P-6E-SI
ID	1500694	1500695
with MDF, EDF and SF	SRM 32-H-180-3-M-4P-6E-SF	SRM 32-H-180-90-M-4P-6E-SF
ID	1500702	1500703

① The complete or supplementary technical data of all possible combinations can be found in the catalog below or at schunk.com.

Main view of basic version with hydraulic damping

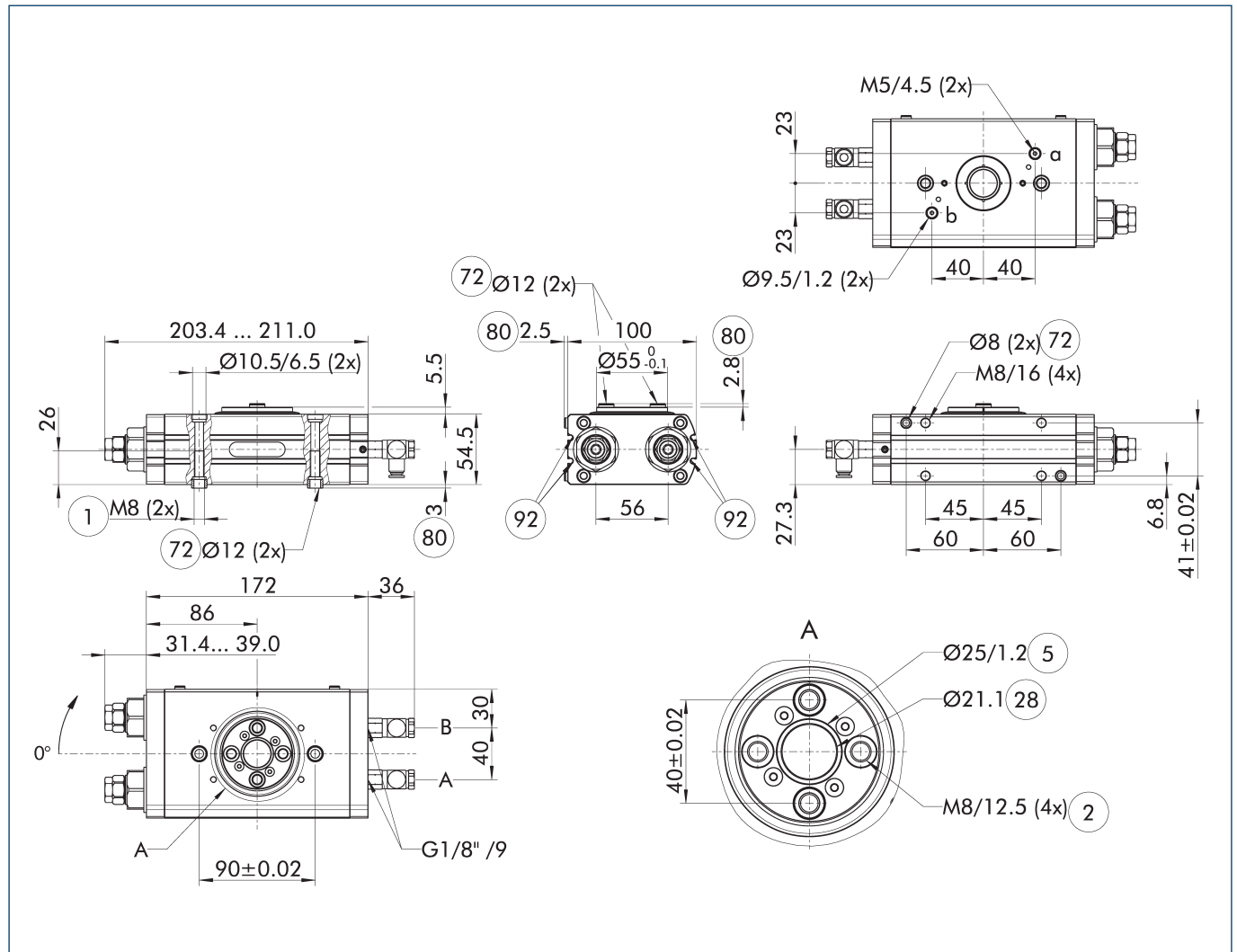

The drawing shows the unit in standard design, without considering any dimensions of the options described below.

① The SDV-P pressure maintenance valve can be used to maintain the position in the case of a loss of pressure (see "Accessories" catalog section).

A, a Main / direct connection, rotary actuator rotates clockwise

B, b Main / direct connection, rotary actuator rotates counterclockwise

① Connection swivel unit

② Attachment connection

⑤ O-ring

②⑧ Through-hole

⑦② Fit for centering sleeves

⑧① Depth of the centering sleeve hole in the counter part

⑨② Sensor MMS 22..

Exemplary design

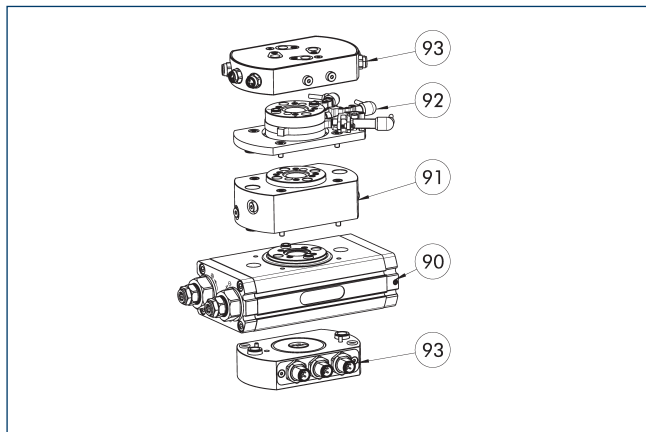

- ⑨⑩ SRM basis
- ⑨① Option MDF
- ⑨② Option SI
- ⑨③ Option EDF

The drawing shows an example of the SRM with the maximum possible number of optional modules. The SRM can be ordered as a basic version without optional modules, with each option individually, or as a combination of several optional modules. The unit is supplied fully assembled. The options cannot be ordered separately. You can find a list of the available combinations including IDs in the technical data table.

Total height

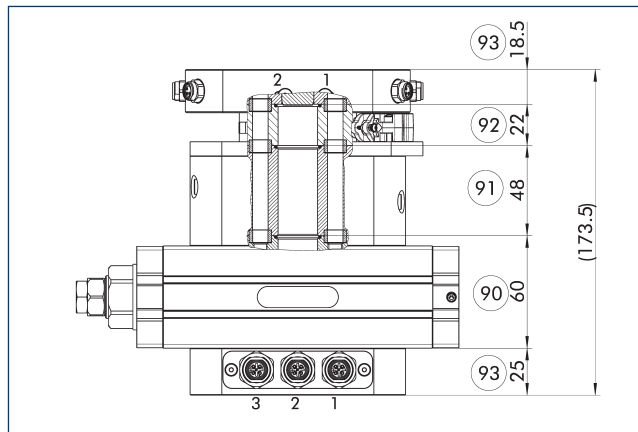

- ⑨⑩ Total height SRM basic version
- ⑨① Additional dimension of the attached module, option MDF
- ⑨② Additional dimension of the attached module, option SI/SF
- ⑨③ Additional dimension of the attached module, option EDF

The drawing shows the maximum additional dimension. Depending on the selected optional modules, the total height is reduced accordingly

Main view option of media feed-through MDF

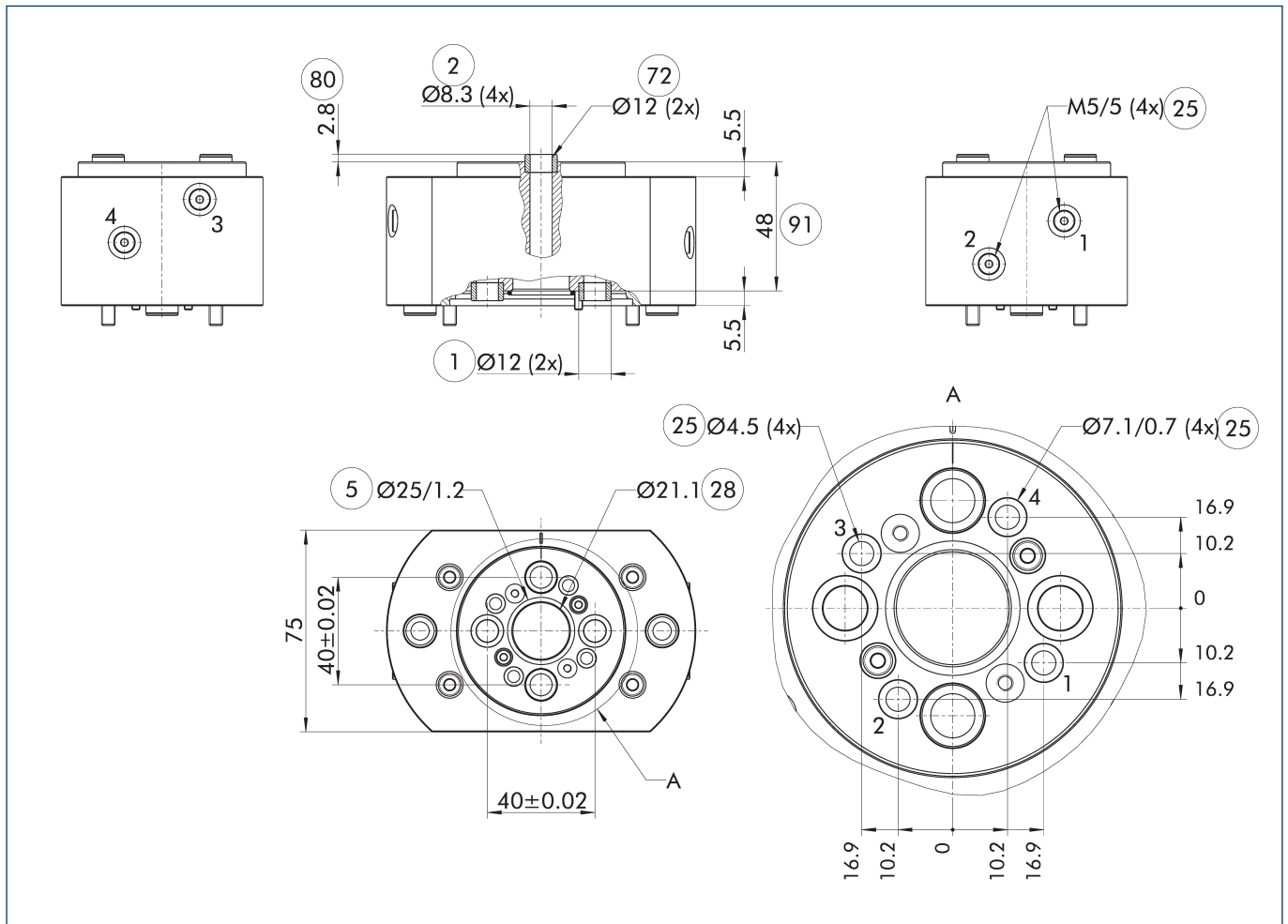

The drawing shows the option of media feed-through, without the base module or other options for the swivel unit.

- ① Connection swivel unit
- ② Attachment connection
- ⑤ O-ring
- ②⑤ Fluid feed-through
- ②⑧ Through-hole
- ⑦② Fit for centering sleeves
- ⑧①① Depth of the centering sleeve hole in the counter part
- ⑧①① Additional dimension of the attached module, option MDF

Reduction of torque at 6 bar in the fluid feed-through	Weight of the module without base unit	No. of fluid feed-throughs	Min. pressure in the fluid feed-through	Nominal pressure of fluid feed-through	Max. pressure fluid feed-through	Max. volumetric flow of feed-through (at 6 bar)	Diameter of center bore
[Nm]	[kg]		[bar]	[bar]	[bar]	[l/min]	[mm]
Option for media feed-through MDF							
- 4	0.93	4	-0.8	6	8	200	21.1

① This option cannot be ordered separately. It is a part of a configured version of the swivel unit. For the complete technical data of all the possible combination options, please configure the swivel unit at schunk.com. Please note that the above-mentioned data refer only to the option and not to the complete unit.

Main view option of electric rotary feed-through EDF

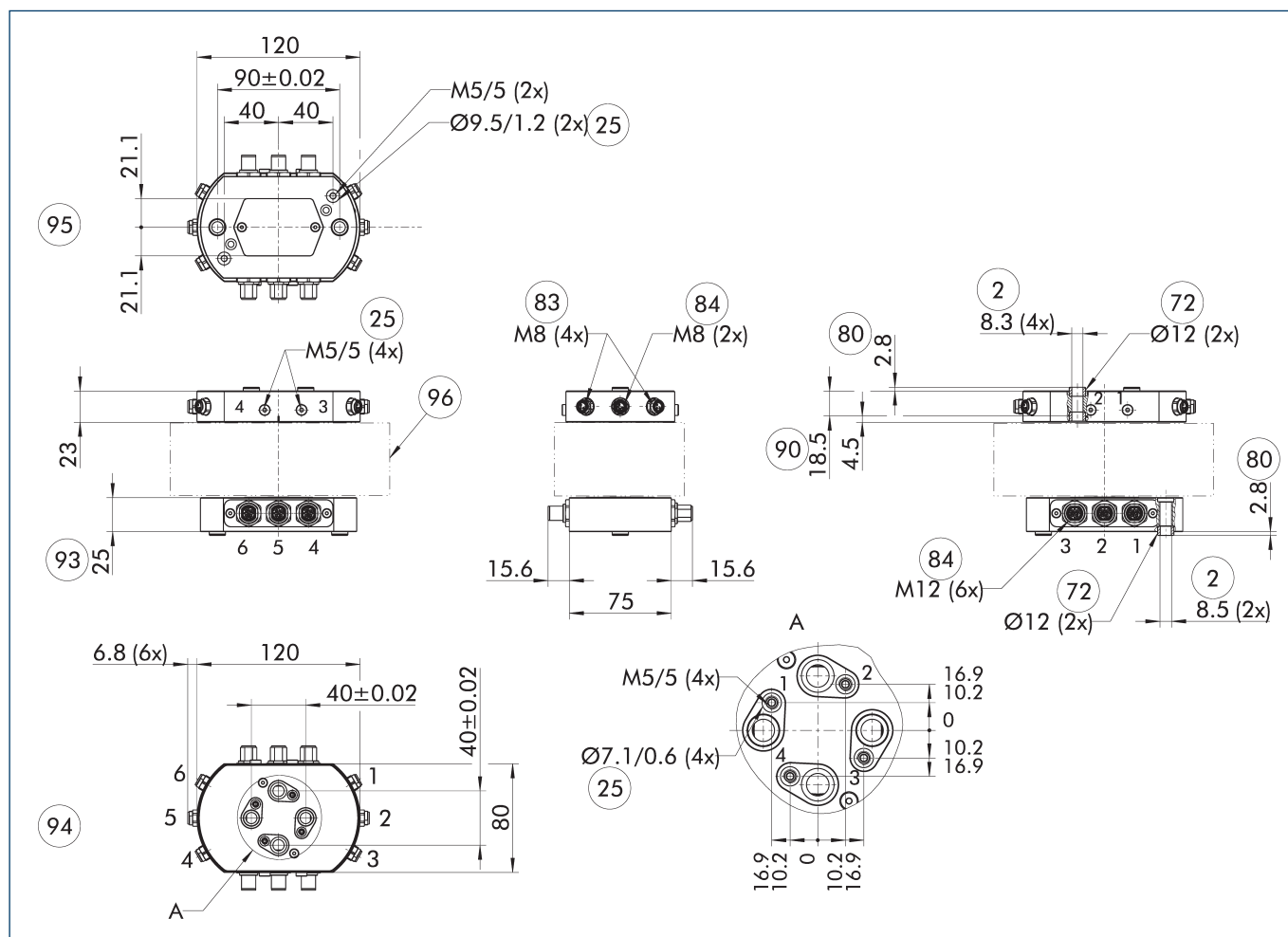

The drawing shows the option of an electric rotary feed-through without the base module or other options for the swivel unit.

- A, a Main / direct connection, rotary actuator rotates clockwise
- B, b Main / direct connection, rotary actuator rotates counterclockwise
- ② Attachment connection
- ②⑤ Fluid feed-through
- ⑦② Fit for centering sleeves
- ⑧① Depth of the centering sleeve hole in the counter part
- ⑧③ Input for 3 pole sensor feed-through
- ⑧④ Input for 4 pole sensor feed-through
- ⑨①① Additional dimension of the attached module, option EDF output side
- ⑨③③ Additional dimension of the attached module, option EDF drive side
- ⑨④④ EDF drive side hidden from view
- ⑨⑤⑤ EDF output side hidden from view
- ⑨⑥⑥ SRM basis and other options

Weight of the module without base unit	Size of the socket (output)	Size of the connector (drive)	Number of wires	Max. voltage	Max. current per wire	Max. ambient temperature
[kg]				[V]	[A]	[°C]
Optional electric rotary feed-through EDF						
0.78	4xM8/3-polig 2xM8/4-polig	6xM12/4-polig	20	48	1	60

① This option cannot be ordered separately. It is a part of a configured version of the swivel unit. For the complete technical data of all the possible combination options, please configure the swivel unit at schunk.com. Please note that the above-mentioned data refer only to the option and not to the complete unit.

SRM 32

Universal swivel unit

Main view option for inductive proximity switches

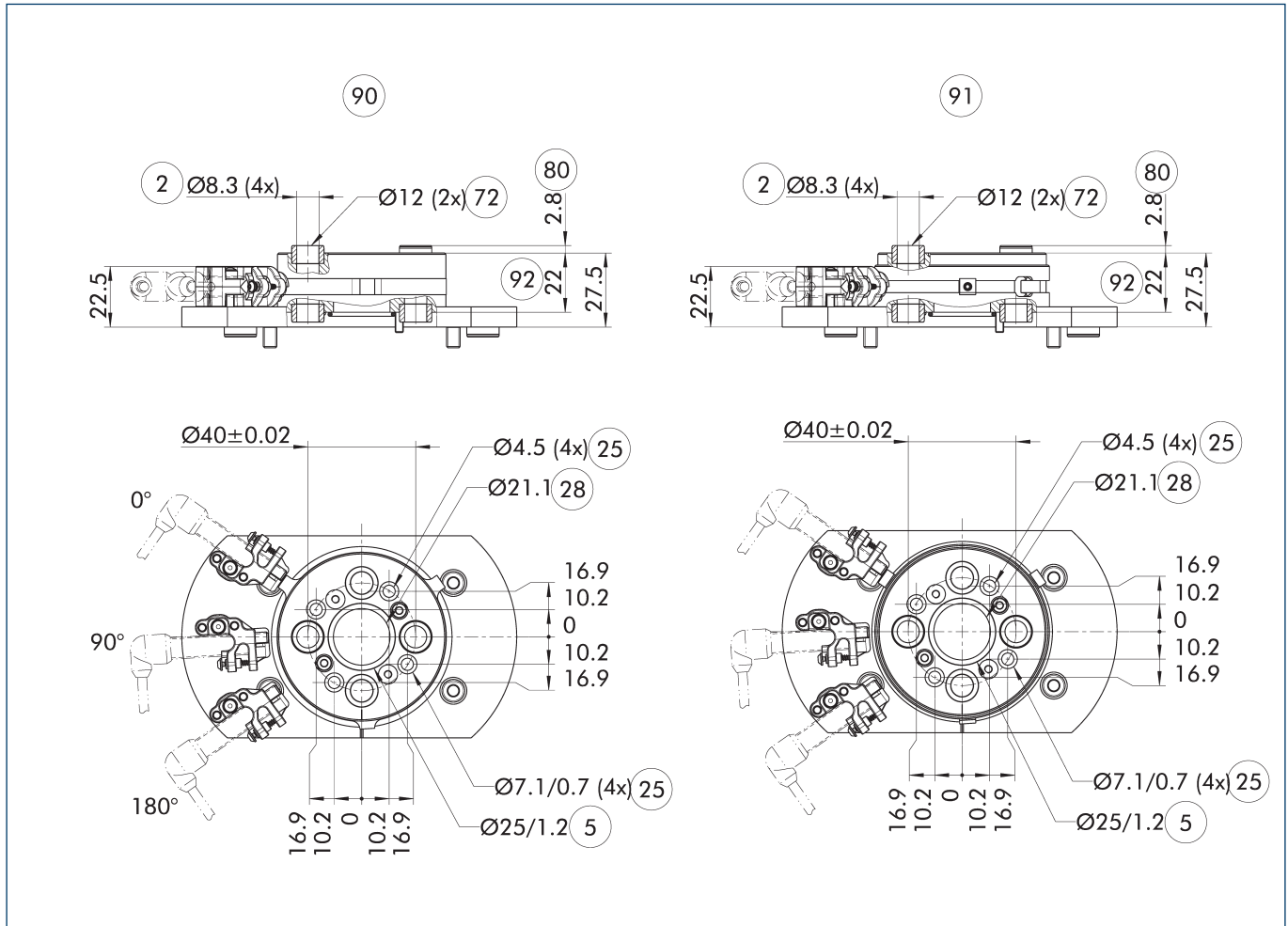

The drawing shows the option of using inductive proximity switches without the base module or other options for the swivel unit. With this option, up to three positions can be monitored with inductive sensors. Option SI offers adjustable monitoring positions, SF offers fixed positions.

- ② Attachment connection
- ⑤ O-ring
- ②⑤ Fluid feed-through
- ②⑧ Through-hole
- ⑦② Fit for centering sleeves
- ⑧①② Depth of the centering sleeve hole in the counter part
- ⑨① Inductive monitoring of fixed position (SF)
- ⑨① Inductive monitoring of adjustable position (SI)
- ⑨② Additional dimension of the attached module, option SI/SF

Description	Position monitoring is adjustable	Weight of the module without base unit [kg]
Option for inductive proximity switches		
SF 32		0.52
SI 32	yes	0.27

① This option can either be ordered as a mounting kit or as part of a configured version of the swivel unit. For the complete technical data of all the possible combination options, please configure the swivel unit at schunk.com. Please note that the above-mentioned data refer only to the option and not to the complete unit.

Hose-free direct connection G1/8"

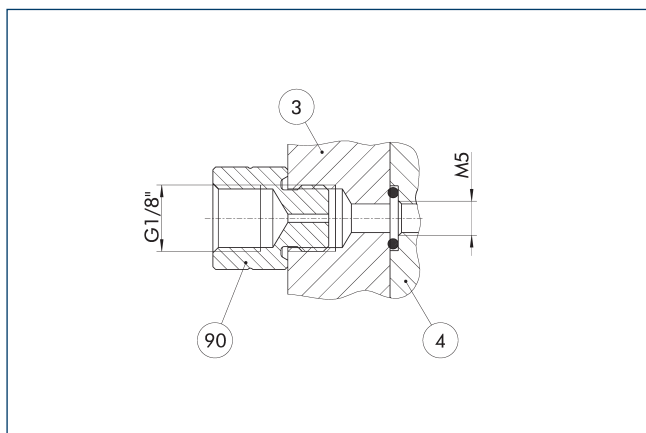

- ③ Adapter
- ④ Rotary unit
- ⑨0 Fixed throttle

The direct connection is used for compressed air supply without error-prone tubing. Instead, the pressure medium is fed through the bore-holes in the mounting plate. The required O-ring as well as the fixed throttle are enclosed to the product's accessory kit.

Large end position adjustability 90°

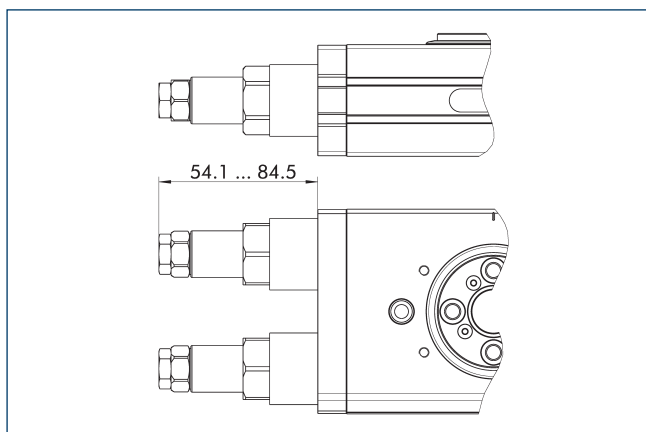

The drawing shows the change in dimension of the "large end position adjustability (90°)" option as compared to the basic variant. The option permits the end positions to be adjusted by up to 93°. More information can be found in the introduction to the series.

Adapter for SCHUNK gripper

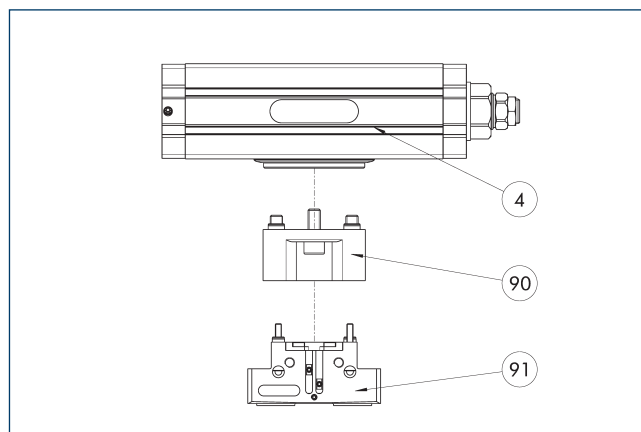

- ④ Rotary unit
- ⑨0 Adapter plate
- ⑨1 Grippers

Adapter plates are available for mounting many types of SCHUNK grippers. All combinations of swivel/gripping units, and associated adapter plates can be configured in the SCHUNK PARTCommunity and downloaded as a 3D model.

Pneumatic middle position (M)

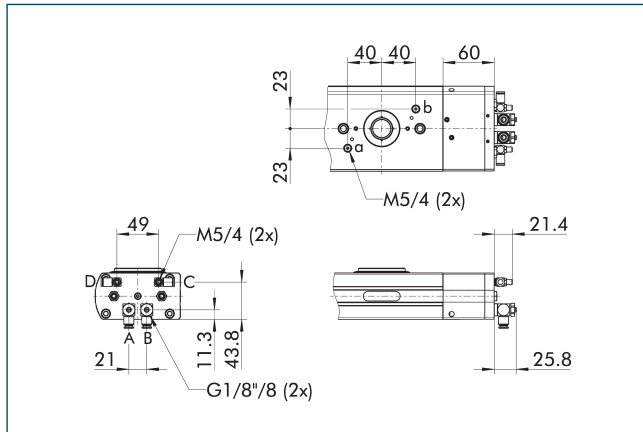

A, a Main / direct connection, rotary actuator rotates clockwise

B, b Main / direct connection, rotary actuator rotates counterclockwise

C Main connection center position

D Main connection center position

The drawing shows the change in dimension of the "pneumatic center position (M)" option compared to the basic variant. Heavy attachments may swing before they reach the final position.

IN 80 inductive proximity switches

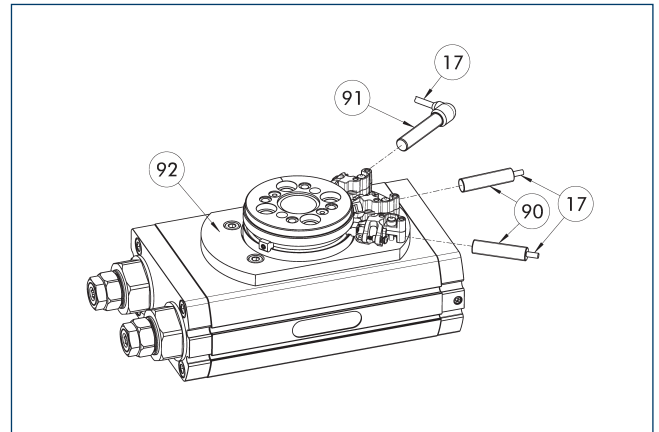

17 Cable outlet

90 Sensor IN ...

91 Sensor IN...-SA

92 Option SI/SF

End and intermediate position monitoring can be mounted with mounting kit

Description	ID	Often combined
Attachment kit for proximity switch		
AS-NHS-SF-SRM 32	1483238	
AS-NHS-SI-SRM 32	1483236	
Inductive proximity switch		
IN 80-0-M12	0301588	
IN 80-0-M8	0301488	
IN 80-S-M12	0301578	
IN 80-S-M8	0301478	●
INK 80-0	0301551	
INK 80-S	0301550	
Inductive proximity switch with lateral cable outlet		
IN 80-S-M12-SA	0301587	
IN 80-S-M8-SA	0301483	●
INK 80-S-SA	0301566	

① Two or three sensors (closer/S) are required for each unit, as well as optional extension cables. Please consider the minimum permissible bending radii for sensor cables. These are generally 35 mm.

Electronic magnetic switch MMS

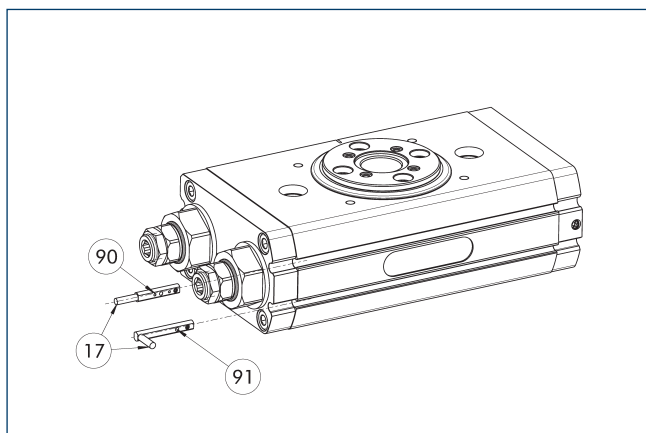

- ①7 Cable outlet
 ①90 Sensor MMS 22..
 ①91 Sensor MMS 22...-SA

End position monitoring for mounting in the C-slot.

Description	ID	Often combined
Electronic magnetic switch		
MMS 22-S-M8-PNP	0301032	●
MMSK 22-S-PNP	0301034	
Electronic magnetic switches with lateral cable outlet		
MMS 22-S-M8-PNP-SA	0301042	●
MMSK 22-S-PNP-SA	0301044	
Connection cables		
KA BG08-L 3P-0300-PNP	0301622	●
KA BG08-L 3P-0500-PNP	0301623	
KA BW08-L 3P-0300-PNP	0301594	
KA BW08-L 3P-0500-PNP	0301502	
Clip for connector/socket		
CLI-M8	0301463	
Cable extension		
KV BW08-SG08 3P-0030-PNP	0301495	
KV BW08-SG08 3P-0100-PNP	0301496	
KV BW08-SG08 3P-0200-PNP	0301497	●
Sensor distributor		
V2-M8	0301775	●
V4-M8	0301746	
V8-M8	0301751	

- ① Two sensors are required per unit for monitoring two positions. On option, extension cables and sensor distributors are available. Additional product variants of the sensor, and further information and technical data can be found in the catalog chapter sensor system.

Programmable magnetic switch MMS 22-PI1

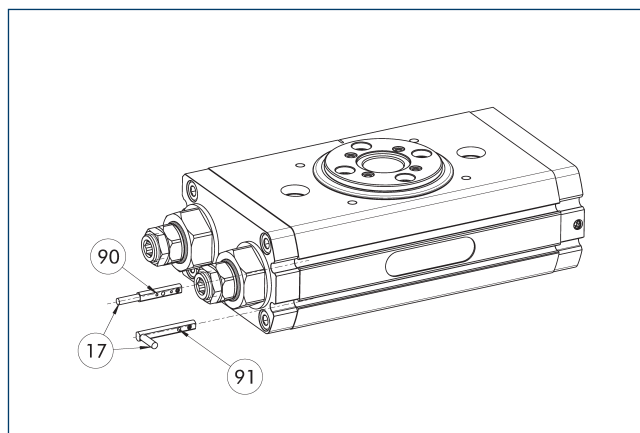

- ①7 Cable outlet
 ①90 Sensor MMS 22 PI1-...
 ①91 Sensor MMS 22 ..-PI1-...-SA

Position monitoring with one programmable position per sensor and integrated electronic system in the sensor. Can be programmed using MT magnetic teaching tool (included in the scope of delivery, ID 0301030) or ST plug teaching tool (optional). End position monitoring for mounting in the C-slot. If the ST plug teaching tools are listed in the table provided, teaching is only possible with the ST teaching tools.

Description	ID	Often combined
Programmable magnetic switch		
MMS 22-PI1-S-M8-PNP	0301160	●
MMSK 22-PI1-S-PNP	0301162	
Programmable magnetic switch with lateral cable outlet		
MMS 22-PI1-S-M8-PNP-SA	0301166	●
MMSK 22-PI1-S-PNP-SA	0301168	
Programmable magnetic switch with stainless steel housing		
MMS 22-PI1-S-M8-PNP-HD	0301110	●
MMSK 22-PI1-S-PNP-HD	0301112	

- ① Two sensors are required per unit for monitoring two positions. On option, extension cables and sensor distributors are available. Additional product variants of the sensor, and further information and technical data can be found in the catalog chapter sensor system.

SRM 40

Universal swivel unit

Dimensions and maximum loads

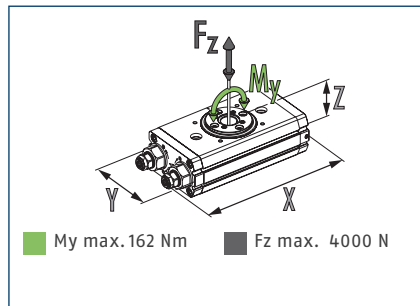

① The indicated moments and forces are static values, valid for the base unit, and may appear simultaneously. Throttling has to be done for ensuring that the rotary movement takes place without impact or bouncing. Otherwise the service life reduces.

Technical data SRM

Description	SRM 40-H-90-3	SRM 40-H-180-3	SRM 40-H-180-90
ID	1347385	1331301	1347433
End position damping	hydr. damper	hydr. damper	hydr. damper
Angle of rotation	[°] 90.0	180.0	180.0
End position adjustability	[°] +3/-3	+3/-3	+3/-93
Torque	[Nm] 23.7	23.7	23.7
Number of intermediate positions	none	none	none
IP protection class	65	65	65
Weight	[kg] 5.93	5.93	6.55
Fluid consumption (2x nom. angle)	[cm ³] 172.0	333.0	333.0
Min./nom./max. operating pressure	[bar] 4/6/6.5	4/6/6.5	4/6/6.5
Diameter of connecting hose	8 x 6 x 1	8 x 6 x 1	8 x 6 x 1
Min./max. ambient temperature	[°C] 5/60	5/60	5/60
Cleanroom class ISO 14644-1:2015	5	5	5
Repeat accuracy	[°] 0.05	0.05	0.05
Diameter of center bore	[mm] 26.1	26.1	26.1
Max. permissible mass moment of inertia	[kgm ²] 7	7	7
Dimensions X x Y x Z	[mm] 260.1 x 120 x 72	260.1 x 120 x 72	323 x 120 x 72
Options			
with media feed-through (MDF)	SRM 40-H-90-3-4P	SRM 40-H-180-3-4P	SRM 40-H-180-90-4P
ID	1347388	1331302	1347435
with electrical feed-throughs (EDF)	SRM 40-H-90-3-10E	SRM 40-H-180-3-10E	SRM 40-H-180-90-10E
ID	1347394	1331304	1347436
for inductive Sensors, adjustable (SI)	SRM 40-H-90-3-SI	SRM 40-H-180-3-SI	SRM 40-H-180-90-SI
ID	1347417	1347375	1347446
for inductive Sensors, fixed (SF)	SRM 40-H-90-3-SF	SRM 40-H-180-3-SF	SRM 40-H-180-90-SF
ID	1357532	1357513	1357520
with MDF and EDF	SRM 40-H-90-3-4P-10E	SRM 40-H-180-3-4P-10E	SRM 40-H-180-90-4P-10E
ID	1347398	1331306	1347440
with MDF and SI	SRM 40-H-90-3-4P-SI	SRM 40-H-180-3-4P-SI	SRM 40-H-180-90-4P-SI
ID	1347420	1347378	1347453
with MDF and SF	SRM 40-H-90-3-4P-SF	SRM 40-H-180-3-4P-SF	SRM 40-H-180-90-4P-SF
ID	1357533	1357515	1357521
with EDF and SI	SRM 40-H-90-3-10E-SI	SRM 40-H-180-3-10E-SI	SRM 40-H-180-90-10E-SI
ID	1347424	1347379	1347455
with EDF and SF	SRM 40-H-90-3-10E-SF	SRM 40-H-180-3-10E-SF	SRM 40-H-180-90-10E-SF
ID	1357536	1357516	1357522
with MDF, EDF and SI	SRM 40-H-90-3-4P-10E-SI	SRM 40-H-180-3-4P-10E-SI	SRM 40-H-180-90-4P-10E-SI
ID	1347427	1347381	1347461
with MDF, EDF and SF	SRM 40-H-90-3-4P-10E-SF	SRM 40-H-180-3-4P-10E-SF	SRM 40-H-180-90-4P-10E-SF
ID	1357539	1357518	1357526

① The complete or supplementary technical data of all possible combinations can be found in the catalog below or at schunk.com.

Max. permissible inertia J*

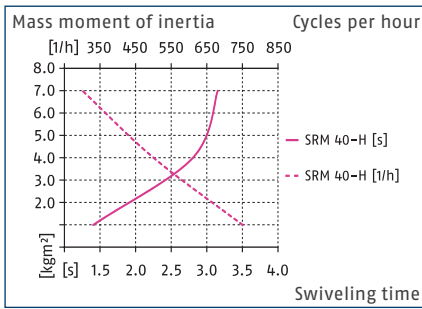

* *The diagrams are valid for basic units and for applications with a vertical swivel axis as well as for absolutely centric loads with a horizontal swivel axis and with an operating pressure of 6 bar. The swiveling times per throttling have to be observed, otherwise the life time may reduce. We will be happy to help you designing other applications. In addition, the SCHUNK Swiveling sizing assistant is available online.

Technical data SRM with center position

Description	SRM 40-H-180-3-M	SRM 40-H-180-90-M
ID	1482234	1482235
End position damping	hydr. damper	hydr. damper
Angle of rotation	[°] 180.0	180.0
End position adjustability	[°] +3/-3	+3/-93
Torque	[Nm] 23.7	23.7
Torque center position	[Nm] 12.5	12.5
Number of intermediate positions	1 x M (pneumatic)	1 x M (pneumatic)
Adjustability of middle position	[°] +3/-3	+3/-3
IP protection class	65	65
Weight	[kg] 7.35	7.95
Fluid consumption (2x nom. angle)	[cm³] 380.0	380.0
Min./nom./max. operating pressure	[bar] 4/6/6.5	4/6/6.5
Diameter of connecting hose	8 x 6 x 1	8 x 6 x 1
Min./max. ambient temperature	[°C] 5/60	5/60
Cleanroom class ISO 14644-1:2015	5	5
Repeat accuracy	[°] 0.05	0.05
Diameter of center bore	[mm] 26.1	26.1
Max. permissible mass moment of inertia	[kgm²] 1.49	1.49
Dimensions X x Y x Z	[mm] 352 x 120 x 72	415 x 120 x 72
Options		
with media feed-through (MDF)	SRM 40-H-180-3-M-4P	SRM 40-H-180-90-M-4P
ID	1482236	1482237
with electrical feed-throughs (EDF)	SRM 40-H-180-3-M-10E	SRM 40-H-180-90-M-10E
ID	1482238	1482239
for inductive Sensors, adjustable (SI)	SRM 40-H-180-3-M-SI	SRM 40-H-180-90-M-SI
ID	1482242	1482243
for inductive Sensors, fixed (SF)	SRM 40-H-180-3-M-SF	SRM 40-H-180-90-M-SF
ID	1482250	1482251
with MDF and EDF	SRM 40-H-180-3-M-4P-10E	SRM 40-H-180-90-M-4P-10E
ID	1482240	1482241
with MDF and SI	SRM 40-H-180-3-M-4P-SI	SRM 40-H-180-90-M-4P-SI
ID	1482244	1482245
with MDF and SF	SRM 40-H-180-3-M-4P-SF	SRM 40-H-180-90-M-4P-SF
ID	1482252	1482253
with EDF and SI	SRM 40-H-180-3-M-10E-SI	SRM 40-H-180-90-M-10E-SI
ID	1482246	1482247
with EDF and SF	SRM 40-H-180-3-M-10E-SF	SRM 40-H-180-90-M-10E-SF
ID	1482254	1482255
with MDF, EDF and SI	SRM 40-H-180-3-M-4P-10E-SI	SRM 40-H-180-90-M-4P-10E-SI
ID	1482248	1482249
with MDF, EDF and SF	SRM 40-H-180-3-M-4P-10E-SF	SRM 40-H-180-90-M-4P-10E-SF
ID	1482256	1482257

① The complete or supplementary technical data of all possible combinations can be found in the catalog below or at schunk.com.

SRM 40

Universal swivel unit

Main view of basic version with hydraulic damping

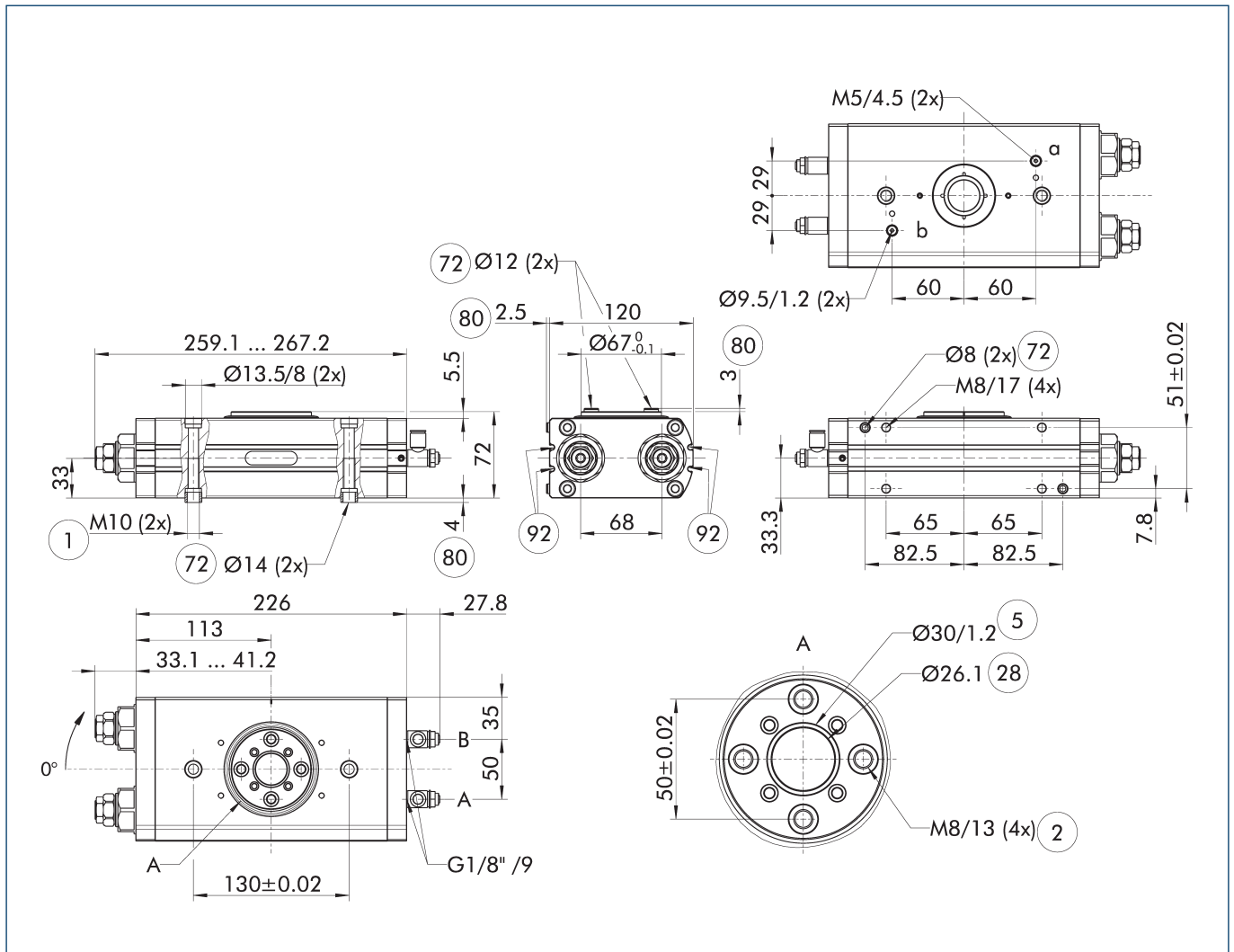

The drawing shows the unit in standard design, without considering any dimensions of the options described below.

① The SDV-P pressure maintenance valve can be used to maintain the position in the case of a loss of pressure (see "Accessories" catalog section).

A, a Main / direct connection, rotary actuator rotates clockwise

B, b Main / direct connection, rotary actuator rotates counterclockwise

① Connection swivel unit

② Attachment connection

⑤ O-ring

②⑧ Through-hole

⑦② Fit for centering sleeves

⑧①① Depth of the centering sleeve hole in the counter part

⑨② Sensor MMS 22..

Exemplary design

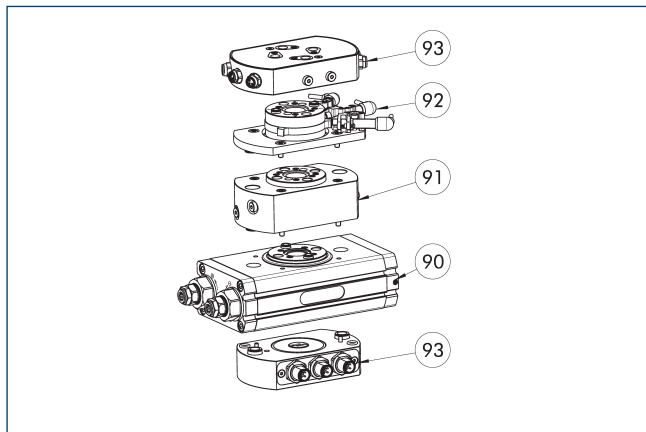

- ⑨⑩ SRM basis
- ⑨① Option MDF
- ⑨② Option SI
- ⑨③ Option EDF

The drawing shows an example of the SRM with the maximum possible number of optional modules. The SRM can be ordered as a basic version without optional modules, with each option individually, or as a combination of several optional modules. The unit is supplied fully assembled. The options cannot be ordered separately. You can find a list of the available combinations including IDs in the technical data table.

Total height

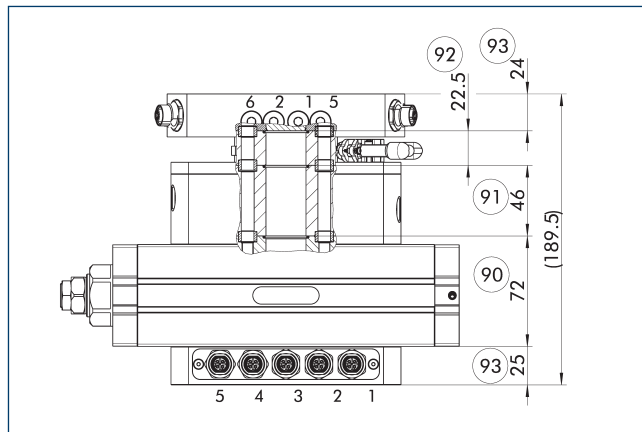

- ⑨⑩ Total height SRM basic version
- ⑨① Additional dimension of the attached module, option MDF
- ⑨② Additional dimension of the attached module, option SI/SF
- ⑨③ Additional dimension of the attached module, option EDF

The drawing shows the maximum additional dimension. Depending on the selected optional modules, the total height is reduced accordingly

Main view option of media feed-through MDF

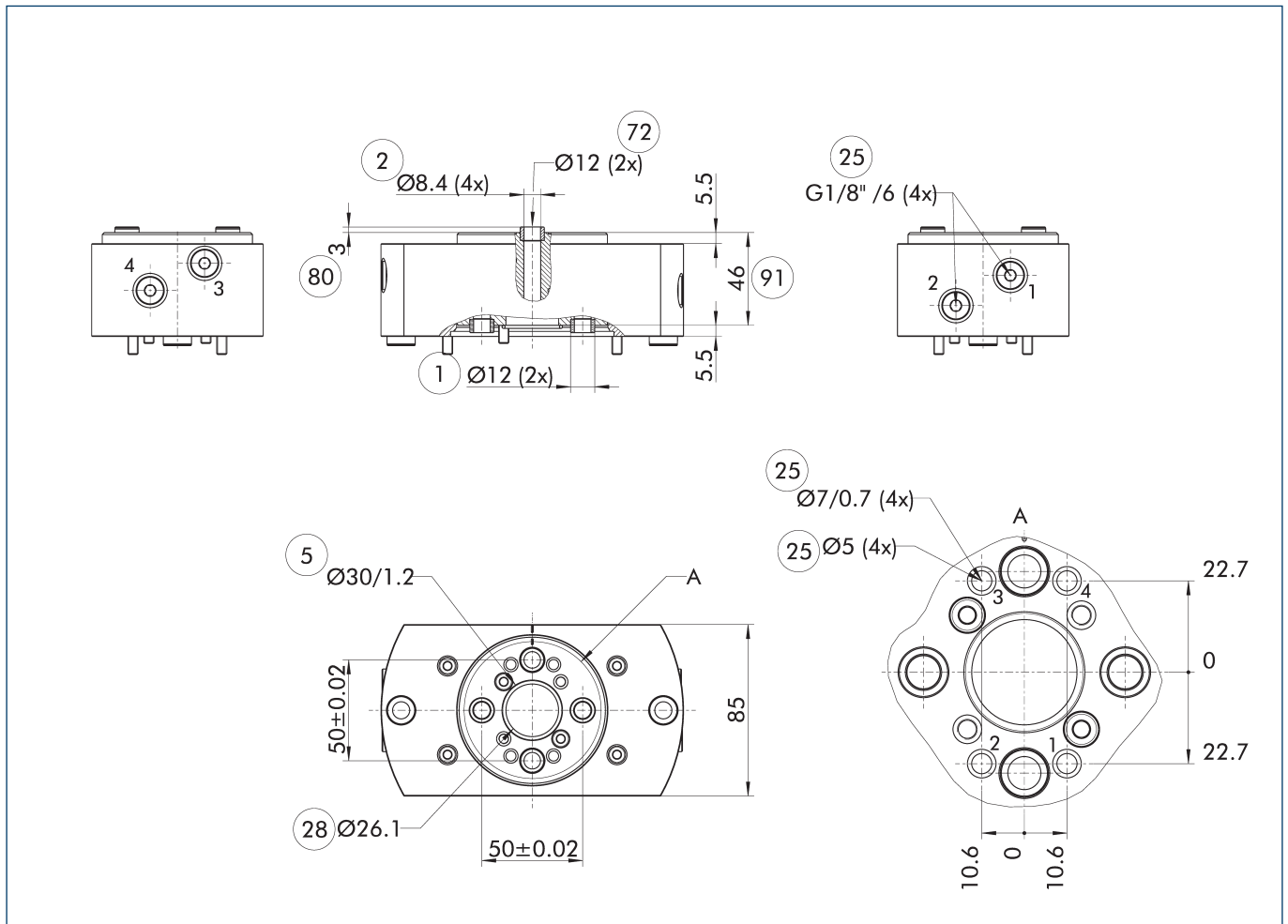

The drawing shows the option of media feed-through, without the base module or other options for the swivel unit.

- ① Connection swivel unit
- ② Attachment connection
- ⑤ O-ring
- ⑫ Fluid feed-through
- ⑬ Through-hole
- ⑰ Fit for centering sleeves
- ⑱ Depth of the centering sleeve hole in the counter part
- ⑲ Additional dimension of the attached module, option MDF

Reduction of torque at 6 bar in the fluid feed-through	Weight of the module without base unit	No. of fluid feed-throughs	Min. pressure in the fluid feed-through	Nominal pressure of fluid feed-through	Max. pressure fluid feed-through	Max. volumetric flow of feed-through (at 6 bar)	Diameter of center bore
[Nm]	[kg]		[bar]	[bar]	[bar]	[l/min]	[mm]
Option for media feed-through MDF							
- 3	1.34	4	-0.8	6	8	340	26.1

① This option cannot be ordered separately. It is a part of a configured version of the swivel unit. For the complete technical data of all the possible combination options, please configure the swivel unit at schunk.com. Please note that the above-mentioned data refer only to the option and not to the complete unit.

Main view option of electric rotary feed-through EDF

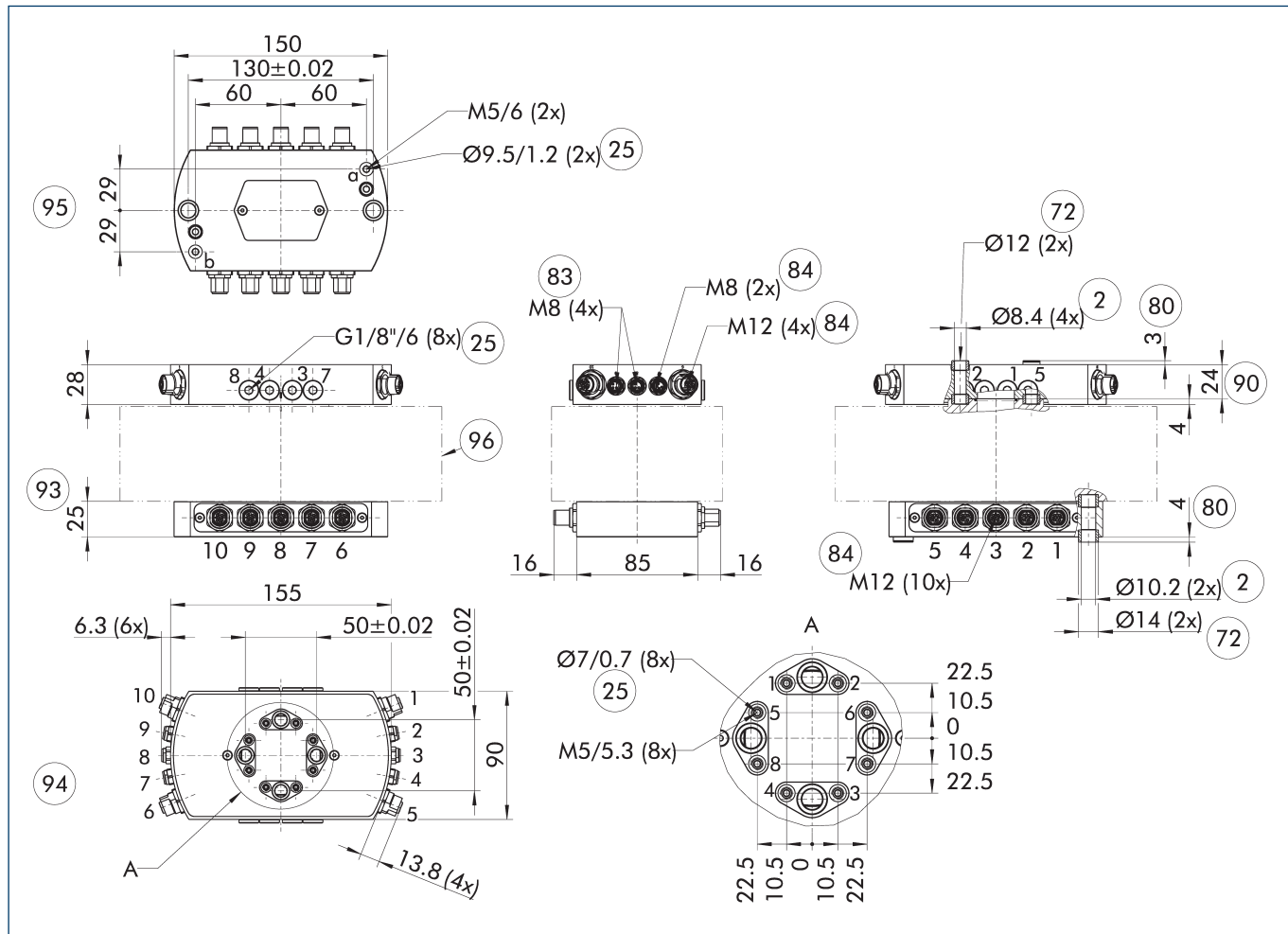

The drawing shows the option of an electric rotary feed-through without the base module or other options for the swivel unit.

- A, a Main / direct connection, rotary actuator rotates clockwise
- B, b Main / direct connection, rotary actuator rotates counterclockwise
- ② Attachment connection
- ②⑤ Fluid feed-through
- ⑦② Fit for centering sleeves
- ⑧① Depth of the centering sleeve hole in the counter part
- ⑧③ Input for 3 pole sensor feed-through
- ⑧④ Input for 4 pole sensor feed-through
- ⑨① Additional dimension of the attached module, option EDF output side
- ⑨③ Additional dimension of the attached module, option EDF drive side
- ⑨④ EDF drive side hidden from view
- ⑨⑤ EDF output side hidden from view
- ⑨⑥ SRM basis and other options

Weight of the module without base unit	Size of the socket (output)	Size of the connector (drive)	Number of wires	Max. voltage	Max. current per wire	Max. ambient temperature
[kg]				[V]	[A]	[°C]
Optional electric rotary feed-through EDF						
1.19	10xM12/4-polig	4xM8/3-polig 2xM8/4-polig 4xM12/4-polig	36	48	1	60

① This option cannot be ordered separately. It is a part of a configured version of the swivel unit. For the complete technical data of all the possible combination options, please configure the swivel unit at schunk.com. Please note that the above-mentioned data refer only to the option and not to the complete unit.

SRM 40

Universal swivel unit

Main view option for inductive proximity switches

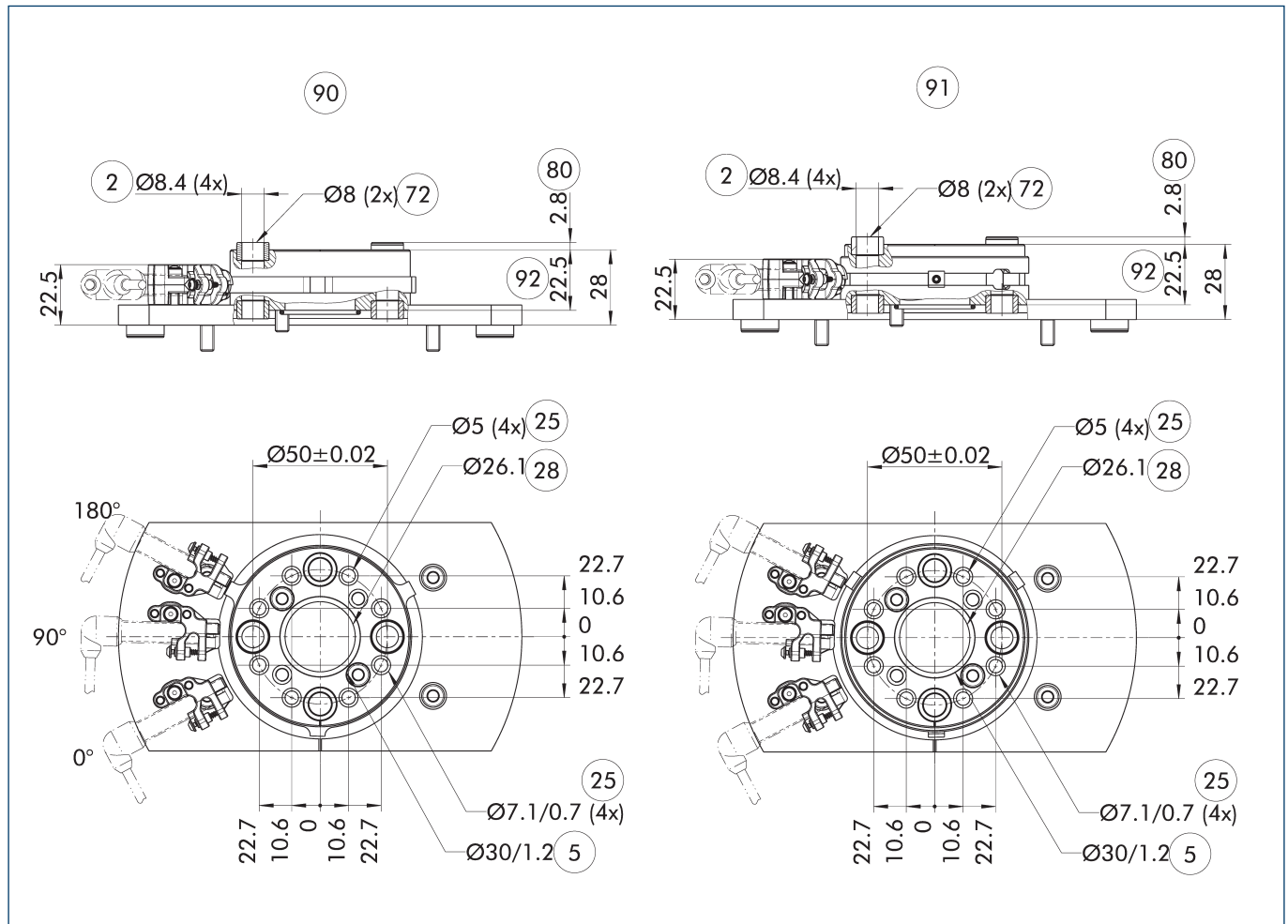

The drawing shows the option of using inductive proximity switches without the base module or other options for the swivel unit. With this option, up to three positions can be monitored with inductive sensors. Option SI offers adjustable monitoring positions, SF offers fixed positions.

- ② Attachment connection
- ⑤ O-ring
- ②⑤ Fluid feed-through
- ②⑧ Through-hole
- ⑦② Fit for centering sleeves
- ⑧⑩ Depth of the centering sleeve hole in the counter part
- ⑨⑩ Inductive monitoring of fixed position (SF)
- ⑨① Inductive monitoring of adjustable position (SI)
- ⑨② Additional dimension of the attached module, option SI/SF

Description	Position monitoring is adjustable	Weight of the module without base unit
		[kg]
Option for inductive proximity switches		
SF 40		0.66
SI 40	yes	0.39

① This option can either be ordered as a mounting kit or as part of a configured version of the swivel unit. For the complete technical data of all the possible combination options, please configure the swivel unit at schunk.com. Please note that the above-mentioned data refer only to the option and not to the complete unit.

Hose-free direct connection G1/8"

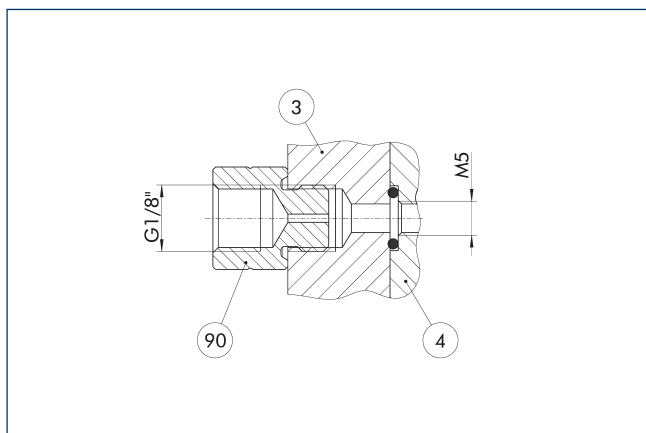

- ③ Adapter
- ④ Rotary unit
- ⑨0 Fixed throttle

The direct connection is used for compressed air supply without error-prone tubing. Instead, the pressure medium is fed through the bore-holes in the mounting plate. The required O-ring as well as the fixed throttle are enclosed to the product's accessory kit.

Large end position adjustability 90°

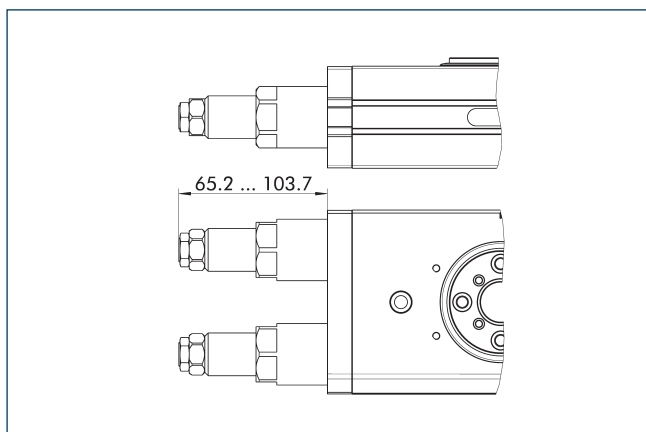

The drawing shows the change in dimension of the "large end position adjustability (90°)" option as compared to the basic variant. The option permits the end positions to be adjusted by up to 93°. More information can be found in the introduction to the series.

Adapter for SCHUNK gripper

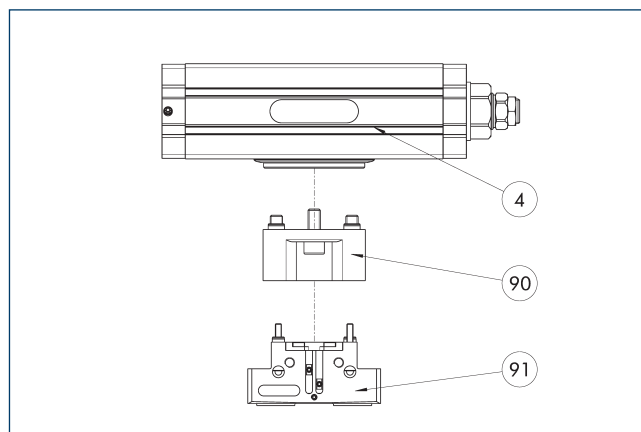

- ④ Rotary unit
- ⑨0 Adapter plate
- ⑨1 Grippers

Adapter plates are available for mounting many types of SCHUNK grippers. All combinations of swivel/gripping units, and associated adapter plates can be configured in the SCHUNK PARTCommunity and downloaded as a 3D model.

SRM 40

Universal swivel unit

Pneumatic middle position (M)

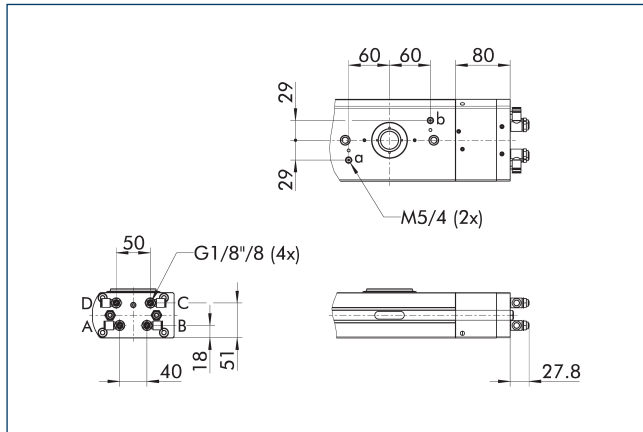

A, a Main / direct connection, rotary actuator rotates clockwise

C Main connection center position

B, b Main / direct connection, rotary actuator rotates counterclockwise

D Main connection center position

The drawing shows the change in dimension of the "pneumatic center position (M)" option compared to the basic variant. Heavy attachments may swing before they reach the final position.

IN 80 inductive proximity switches

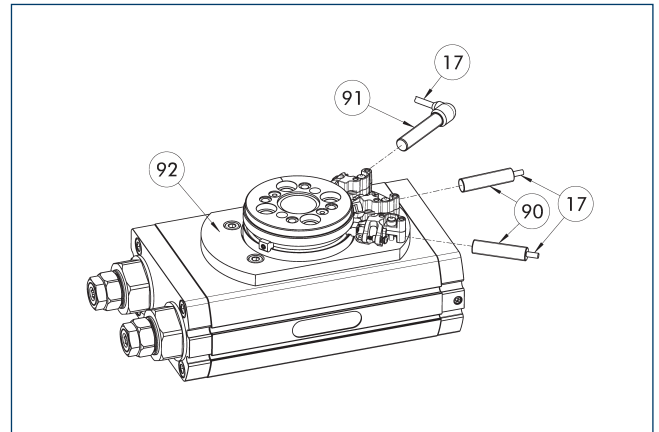

17 Cable outlet

91 Sensor IN...-SA

90 Sensor IN ...

92 Option SI/SF

End and intermediate position monitoring can be mounted with mounting kit

Description	ID	Often combined
Attachment kit for proximity switch		
AS-NHS-SF-SRM 40	1483242	
AS-NHS-SI-SRM 40	1483240	
Inductive proximity switch		
IN 80-0-M12	0301588	
IN 80-0-M8	0301488	
IN 80-S-M12	0301578	
IN 80-S-M8	0301478	●
INK 80-0	0301551	
INK 80-S	0301550	
Inductive proximity switch with lateral cable outlet		
IN 80-S-M12-SA	0301587	
IN 80-S-M8-SA	0301483	●
INK 80-S-SA	0301566	

① Two or three sensors (closer/S) are required for each unit, as well as optional extension cables. Please consider the minimum permissible bending radii for sensor cables. These are generally 35 mm.

Electronic magnetic switch MMS

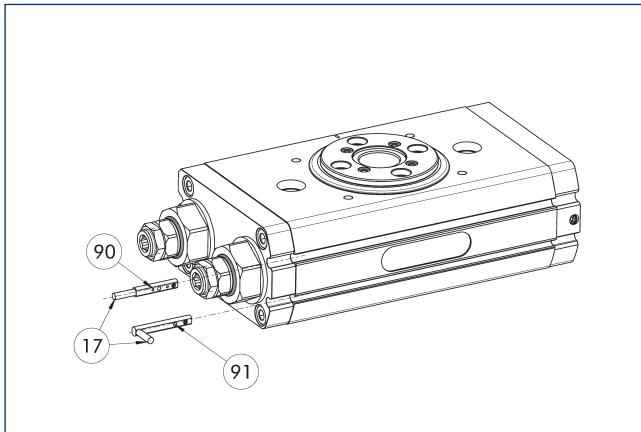

- ⑰ Cable outlet
 ⑨① Sensor MMS 22...-SA

End position monitoring for mounting in the C-slot.

Description	ID	Often combined
Electronic magnetic switch		
MMS 22-S-M8-PNP	0301032	●
MMSK 22-S-PNP	0301034	
Electronic magnetic switches with lateral cable outlet		
MMS 22-S-M8-PNP-SA	0301042	●
MMSK 22-S-PNP-SA	0301044	
Connection cables		
KA BG08-L 3P-0300-PNP	0301622	●
KA BG08-L 3P-0500-PNP	0301623	
KA BW08-L 3P-0300-PNP	0301594	
KA BW08-L 3P-0500-PNP	0301502	
Clip for connector/socket		
CLI-M8	0301463	
Cable extension		
KV BW08-SG08 3P-0030-PNP	0301495	
KV BW08-SG08 3P-0100-PNP	0301496	
KV BW08-SG08 3P-0200-PNP	0301497	●
Sensor distributor		
V2-M8	0301775	●
V4-M8	0301746	
V8-M8	0301751	

- ① Two sensors are required per unit for monitoring two positions. On option, extension cables and sensor distributors are available. Additional product variants of the sensor, and further information and technical data can be found in the catalog chapter sensor system.

Programmable magnetic switch MMS 22-PI1

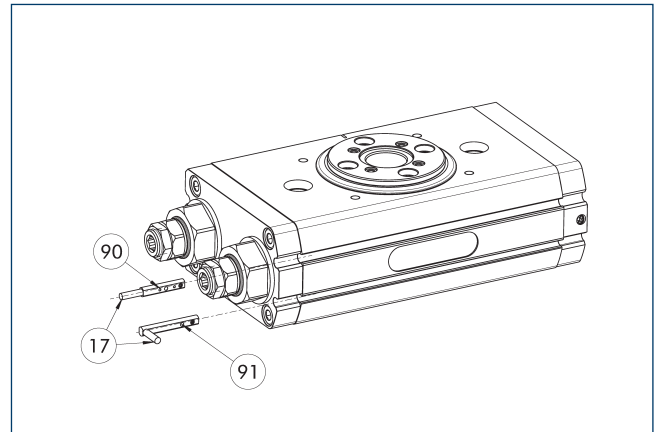

- ⑰ Cable outlet
 ⑨① Sensor MMS 22...-PI1...-SA

Position monitoring with one programmable position per sensor and integrated electronic system in the sensor. Can be programmed using MT magnetic teaching tool (included in the scope of delivery, ID 0301030) or ST plug teaching tool (optional). End position monitoring for mounting in the C-slot. If the ST plug teaching tools are listed in the table provided, teaching is only possible with the ST teaching tools.

Description	ID	Often combined
Programmable magnetic switch		
MMS 22-PI1-S-M8-PNP	0301160	●
MMSK 22-PI1-S-PNP	0301162	
Programmable magnetic switch with lateral cable outlet		
MMS 22-PI1-S-M8-PNP-SA	0301166	●
MMSK 22-PI1-S-PNP-SA	0301168	
Programmable magnetic switch with stainless steel housing		
MMS 22-PI1-S-M8-PNP-HD	0301110	●
MMSK 22-PI1-S-PNP-HD	0301112	

- ① Two sensors are required per unit for monitoring two positions. On option, extension cables and sensor distributors are available. Additional product variants of the sensor, and further information and technical data can be found in the catalog chapter sensor system.



SCHUNK GmbH & Co. KG
Spann- und Greiftechnik

Bahnhofstr. 106 - 134
D-74348 Lauffen/Neckar
Tel. +49-7133-103-0
Fax +49-7133-103-2399
info@de.schunk.com
schunk.com

Folgen Sie uns | *Follow us*

