



# Assembly and operating manual

## CLM

### Compact Linear Module

Translation of the original manual

Hand in hand for tomorrow

## Imprint

### Copyright:

This manual is protected by copyright. The author is SCHUNK SE & Co. KG.  
All rights reserved.

### Technical changes:

We reserve the right to make alterations for the purpose of technical improvement.

**Document number:** 389015

**Version:** 05.00 | 13/02/2024 | en

Dear Customer,

Thank you for trusting our products and our family-owned company, the leading technology supplier of robots and production machines.

Our team is always available to answer any questions on this product and other solutions. Ask us questions and challenge us. We will find a solution!

Best regards,

Your SCHUNK team

Customer Management

Tel. +49-7133-103-2503

Fax +49-7133-103-2189

cmg@de.schunk.com



**Please read the operating manual in full and keep it close to the product.**

## Table of Contents

<b>1 General .....</b>	<b>5</b>
1.1 About this manual.....	5
1.1.1 Presentation of Warning Labels .....	5
1.1.2 Definition of Terms .....	6
1.1.3 Applicable documents .....	6
1.1.4 Sizes.....	6
1.2 Warranty .....	6
1.3 Scope of delivery.....	6
1.4 Accessories .....	7
1.4.1 Sensors .....	7
1.4.2 Rod lock.....	7
1.4.3 Stop screw .....	8
1.4.4 Stop / Sensor for CLM 08.....	8
<b>2 Basic safety notes .....</b>	<b>9</b>
2.1 Intended use.....	9
2.2 Not intended use .....	9
2.3 Constructional changes.....	9
2.4 Spare parts .....	9
2.5 Ambient conditions and operating conditions .....	9
2.6 Personnel qualification .....	10
2.7 Personal protective equipment .....	10
2.8 Notes on safe operation.....	11
2.9 Transport.....	11
2.10 Malfunctions.....	12
2.11 Disposal .....	12
2.12 Fundamental dangers .....	12
2.12.1 Protection during handling and assembly .....	12
2.12.2 Protection during commissioning and operation .....	13
2.12.3 Protection against dangerous movements .....	13
2.12.4 Protection against electric shock.....	14
2.13 Notes on particular risks .....	15
<b>3 Technical Data .....</b>	<b>16</b>
<b>4 Assembly and Settings .....</b>	<b>17</b>
4.1 Mechanical connection.....	17
4.2 Pneumatic connection.....	17

4.3	Adjust stroke, sensors and damping .....	19
4.3.1	Endlagen – Sets CLM 08 .....	19
4.3.2	Endlagen – Sets CLM 10 – 25 .....	19
4.3.3	Endlagen – Sets CLM 50 – 200.....	21
4.4	Setting the speed .....	23
4.5	Adjustment of the shock absorber stroke.....	24
4.6	Mounting the rod lock.....	25
<b>5</b>	<b>Commissioning .....</b>	<b>26</b>
<b>6</b>	<b>Troubleshooting.....</b>	<b>27</b>
6.1	Module does not move .....	27
6.2	Endlagensignal nicht vorhanden .....	27
6.3	Linear module proposes at the end positions .....	27
6.4	Nutzlast schwingt in der Endlage .....	27
<b>7</b>	<b>Maintenance and care .....</b>	<b>28</b>
7.1	Assembly drawings/spare parts .....	29
7.1.1	CLM 08 .....	29
7.1.2	CLM 10.....	30
7.1.3	CLM 25 .....	31
7.1.4	CLM 50, 100 and 200.....	32
<b>8</b>	<b>Translation of the original declaration of incorporation .....</b>	<b>33</b>
<b>9</b>	<b>UKCA declaration of incorporation .....</b>	<b>34</b>
<b>10</b>	<b>Information on the RoHS Directive, REACH Regulation and Substances of Very High Concern (SVHC) .....</b>	<b>35</b>

# 1 General

## 1.1 About this manual

This manual contains important information for a safe and appropriate use of the product.

This manual is an integral part of the product and must be kept accessible for the personnel at all times.

Before starting work, the personnel must have read and understood this operating manual. Prerequisite for safe working is the observance of all safety instructions in this manual.

In addition to these instructions, the documents listed under ▶ 1.1.3 [ 6 ] are applicable.

**NOTE:** The illustrations in this manual are intended to provide a basic understanding and may deviate from the actual version.

### 1.1.1 Presentation of Warning Labels

To make risks clear, the following signal words and symbols are used for safety notes.



#### **⚠ DANGER**

**Dangers for persons!**

Non-observance will inevitably cause irreversible injury or death.



#### **⚠ WARNING**

**Dangers for persons!**

Non-observance can lead to irreversible injury and even death.



#### **⚠ CAUTION**

**Dangers for persons!**

Non-observance can cause minor injuries.

#### **CAUTION**

**Material damage!**

Information about avoiding material damage.

### 1.1.2 Definition of Terms

The term "product" replaces the product name on the title page in this manual.

### 1.1.3 Applicable documents

- General terms of business \*
- Catalog data sheet of the purchased product \*
- Assembly and operating manuals of the accessories \*

Die mit Stern (\*) gekennzeichneten Unterlagen können unter [schunk.com/downloads](https://www.schunk.com/downloads) heruntergeladen werden.

### 1.1.4 Sizes

This operating manual applies to the following sizes:

- CLM 08
- CLM 10
- CLM 25
- CLM 50
- CLM 100
- CLM 200

## 1.2 Warranty

If the product is used as intended, the warranty is valid for 24 months from the ex-works delivery date under the following conditions:

- Observe the specified maintenance and lubrication intervals
- Observe the ambient conditions and operating conditions

Parts touching the workpiece and wear parts are not included in the warranty.

## 1.3 Scope of delivery

The scope of delivery includes

- Compact Linear Module CLM in the version ordered
- Stop collar (CLM08)
- End position damping (CLM10 – CLM 200)

## 1.4 Accessories

A wide range of accessories are available for this product. For information regarding which accessory articles can be used with the corresponding product variants, see catalog data sheet.

### 1.4.1 Sensors

In the delivery state the sensors are mounted on the product. For the exact type designation, technical data and information on handling sensors, see catalog datasheet and assembly and operating manual of the sensor, available at [schunk.com](http://schunk.com).

Designation	CLM					
	08	10	25	50	100	200
Inductive proximity switch NIA50-KT	X	-	-	-	-	-
Inductive proximity switch IN 30	-	X	-	-	X	X
Inductive proximity switch IN 32	-	-	-	-	X	-
Inductive proximity switch IN 40	-	-	X	X	-	-

### 1.4.2 Rod lock

The rod lock prevents weights from falling in the event of energy loss, such as emergency stop situations. The rod lock can also be retrofitted, but this will reduce the useful stroke.

#### CAUTION

##### Damage to the rod lock due to incorrect actuation / overload!

- The rod lock may only be triggered and unlocked when the product has been shut down.
- See the data on static holding force in the catalog. The forces occurring in a clamped condition must not exceed the holding force.
- In the event of a dynamic load or overload (e.g. drop in pressure during movement), the clamping cartridge must be checked and replaced if necessary.



#### ⚠ WARNING

**The rod lock is not a safety component for personal protection in the sense of the Machine Directive.**

Exact specifications and ordering data  catalog.

### 1.4.3 Stop screw

#### **CAUTION**

**Mechanical damage to the linear module by the stop screw is possible!**

Use stop screw LMAS-... only for short strokes, slow stroke speeds and low kinetic energy!

Designation	ID number
LMAS 25	0314156
LMAS 50	0314158
LMAS 100	0314160
LMAS 200	0314162

### 1.4.4 Stop / Sensor for CLM 08

For size CLM 08 a stop is optionally available with integrated sensor.

End stop without sensor system	LMAS 08-KT (included in the scope of delivery)
End stop with sensor system	NIA 50-KT



## 2 Basic safety notes

### 2.1 Intended use

The product is exclusively designed for linear movement of useful loads into any desired position.

- The product may only be used within the scope of its technical data, ▶ 3 [16].
- When implementing and operating components in safety-related parts of the control systems, the basic safety principles in accordance with DIN EN ISO 13849-2 apply. The proven safety principles in accordance with DIN EN ISO 13849-2 also apply to categories 1, 2, 3 and 4.
- The product is intended for installation in a machine/ automated system. The applicable guidelines for the machine/ automated system must be observed and complied with.
- The product is intended for industrial and industry-oriented use.
- Appropriate use of the product includes compliance with all instructions in this manual.

### 2.2 Not intended use

It is not intended use if the product is used, for example, as a pressing tool, stamping tool, lifting gear, guide for tools, cutting tool, clamping device or a drilling tool.

- Any utilization that exceeds or differs from the appropriate use is regarded as misuse.

### 2.3 Constructional changes

#### Implementation of structural changes

Modifications, changes or reworking, e.g. additional threads, holes, or safety devices, can damage the product or impair its functionality or safety.

- Structural changes should only be made with the written approval of SCHUNK.

### 2.4 Spare parts

#### Use of unauthorized spare parts

Using unauthorized spare parts can endanger personnel and damage the product or cause it to malfunction.

- Use only original spare parts or spares authorized by SCHUNK.

### 2.5 Ambient conditions and operating conditions

#### Required ambient conditions and operating conditions

Incorrect ambient and operating conditions can make the product unsafe, leading to the risk of serious injuries, considerable material damage and/or a significant reduction to the product's life span.

- Make sure that the product is used only in the context of its defined application parameters, ▶ 3 [16].

## 2.6 Personnel qualification

### Inadequate qualifications of the personnel

If the personnel working with the product is not sufficiently qualified, the result may be serious injuries and significant property damage.

- All work may only be performed by qualified personnel.
- Before working with the product, the personnel must have read and understood the complete assembly and operating manual.
- Observe the national safety regulations and rules and general safety instructions.

The following personal qualifications are necessary for the various activities related to the product:

#### Trained electrician

Due to their technical training, knowledge and experience, trained electricians are able to work on electrical systems, recognize and avoid possible dangers and know the relevant standards and regulations.

#### Qualified personnel

Due to its technical training, knowledge and experience, qualified personnel is able to perform the delegated tasks, recognize and avoid possible dangers and knows the relevant standards and regulations.

#### Instructed person

Instructed persons were instructed by the operator about the delegated tasks and possible dangers due to improper behaviour.

#### Service personnel of the manufacturer

Due to its technical training, knowledge and experience, service personnel of the manufacturer is able to perform the delegated tasks and to recognize and avoid possible dangers.

## 2.7 Personal protective equipment

### Use of personal protective equipment

Personal protective equipment serves to protect staff against danger which may interfere with their health or safety at work.

- When working on and with the product, observe the occupational health and safety regulations and wear the required personal protective equipment.

- Observe the valid safety and accident prevention regulations.
- Wear protective gloves to guard against sharp edges and corners or rough surfaces.
- Wear heat-resistant protective gloves when handling hot surfaces.
- Wear protective gloves and safety goggles when handling hazardous substances.
- Wear close-fitting protective clothing and also wear long hair in a hairnet when dealing with moving components.

## 2.8 Notes on safe operation

### Incorrect handling of the personnel

Incorrect handling and assembly may impair the product's safety and cause serious injuries and considerable material damage.

- Avoid any manner of working that may interfere with the function and operational safety of the product.
- Use the product as intended.
- Observe the safety notes and assembly instructions.
- Do not expose the product to any corrosive media. This does not apply to products that are designed for special environments.
- Eliminate any malfunction immediately.
- Observe the care and maintenance instructions.
- Observe the current safety, accident prevention and environmental protection regulations regarding the product's application field.

## 2.9 Transport

### Handling during transport

Incorrect handling during transport may impair the product's safety and cause serious injuries and considerable material damage.

- When handling heavy weights, use lifting equipment to lift the product and transport it by appropriate means.
- Secure the product against falling during transportation and handling.
- Stand clear of suspended loads.

## 2.10 Malfunctions

### Behavior in case of malfunctions

- Immediately remove the product from operation and report the malfunction to the responsible departments/persons.
- Order appropriately trained personnel to rectify the malfunction.
- Do not recommission the product until the malfunction has been rectified.
- Test the product after a malfunction to establish whether it still functions properly and no increased risks have arisen.

## 2.11 Disposal

### Handling of disposal

The incorrect handling of disposal may impair the product's safety and cause serious injuries as well as considerable material and environmental harm.

- Follow local regulations on dispatching product components for recycling or proper disposal.

## 2.12 Fundamental dangers

### General

- Observe safety distances.
- Never deactivate safety devices.
- Before commissioning the product, take appropriate protective measures to secure the danger zone.
- Disconnect power sources before installation, modification, maintenance, or calibration. Ensure that no residual energy remains in the system.
- If the energy supply is connected, do not move any parts by hand.
- Do not reach into the open mechanism or movement area of the product during operation.

### 2.12.1 Protection during handling and assembly

#### Incorrect handling and assembly

Incorrect handling and assembly may impair the product's safety and cause serious injuries and considerable material damage.

- Have all work carried out by appropriately qualified personnel.
- For all work, secure the product against accidental operation.
- Observe the relevant accident prevention rules.

- Use suitable assembly and transport equipment and take precautions to prevent jamming and crushing.

### **Incorrect lifting of loads**

Falling loads may cause serious injuries and even death.

- Stand clear of suspended loads and do not step into their swiveling range.
- Never move loads without supervision.
- Do not leave suspended loads unattended.

## **2.12.2 Protection during commissioning and operation**

### **Falling or violently ejected components**

Falling and violently ejected components can cause serious injuries and even death.

- Take appropriate protective measures to secure the danger zone.
- Never step into the danger zone during operation.

## **2.12.3 Protection against dangerous movements**

### **Unexpected movements**

Residual energy in the system may cause serious injuries while working with the product.

- Switch off the energy supply, ensure that no residual energy remains and secure against inadvertent reactivation.
- Never rely solely on the response of the monitoring function to avert danger. Until the installed monitors become effective, it must be assumed that the drive movement is faulty, with its action being dependent on the control unit and the current operating condition of the drive. Perform maintenance work, modifications, and attachments outside the danger zone defined by the movement range.
- To avoid accidents and/or material damage, human access to the movement range of the machine must be restricted. Limit/prevent accidental access for people in this area due through technical safety measures. The protective cover and protective fence must be rigid enough to withstand the maximum possible movement energy. EMERGENCY STOP switches must be easily and quickly accessible. Before starting up the machine or automated system, check that the EMERGENCY STOP system is working. Prevent operation of the machine if this protective equipment does not function correctly.

#### **2.12.4 Protection against electric shock**

##### **Possible electrostatic energy**

Components or assembly groups may become electrostatically charged. When the electrostatic charge is touched, the discharge may trigger a shock reaction leading to injuries.

- The operator must ensure that all components and assembly groups are included in the local potential equalisation in accordance with the applicable regulations.
- While paying attention to the actual conditions of the working environment, the potential equalisation must be implemented by a specialist electrician according to the applicable regulations.
- The effectiveness of the potential equalisation must be verified by executing regular safety measurements.

## 2.13 Notes on particular risks



### **⚠ WARNING**

#### **Risk of injury from objects falling and being ejected!**

Falling and ejected objects during operation can lead to serious injury or death.

- Take appropriate protective measures to secure the danger zone.



### **⚠ WARNING**

#### **Risk of injury due to unexpected movements!**

If the power supply is switched on or residual energy remains in the system, components can move unexpectedly and cause serious injuries.

- Before starting any work on the product: Switch off the power supply and secure against restarting.
- Make sure, that no residual energy remains in the system.



### **⚠ WARNING**

#### **Danger of crushing and impacts during movement of the unit or attachments. Risk of injury due to attachments breaking or becoming loose.**

Surround the unit with a protective barrier during operation.



### **⚠ WARNING**

#### **Risk of injury from uncontrolled movements!**

In the event of a power failure or control system malfunction, components may move uncontrollably and cause serious injuries.

- Secure the product with pressure maintenance valves (e.g. SCHUNK pressure maintenance valves SDV-P for short time holding of every end position).



### **⚠ WARNING**

#### **Risk of burns through contact with hot surfaces!**

Surfaces of components can heat up severely during operation. Skin contact with hot surfaces causes severe burns to the skin.

- For all work in the vicinity of hot surfaces, wear safety gloves.
- Before carrying out any work, make sure that all surfaces have cooled down to the ambient temperature.

### 3 Technical Data

#### Connection data

Designation	CLM
Pressure medium	Compressed air, compressed air quality according to ISO 8573-1:2010 [7:4:4]
Nominal operating pressure [bar]	6
Minimum pressure [bar]	3
Max. pressure [bar]	8
Pressure range for air purge [bar]	0.5 – 1

More technical data is included in the catalog data sheet. Whichever is the latest version.

#### Ambient conditions and operating conditions

Designation	CLM
Ambient temperature [°C]	
min.	+5
max.	+60
Protection class IP *	40
Noise emission [dB(A)]	≤ 70

- \* For use in dirty ambient conditions (e.g. sprayed water, vapors, abrasion or processing dust) SCHUNK offers corresponding product options as standard. SCHUNK also offers customized solutions for special applications in dirty ambient conditions.



## 4 Assembly and Settings

### Assembly measures

- When mounting the module and when mounting loads, do not allow impermissible forces and moments to be exerted (see catalog data)
- Select the suitable screw tightening torque when mounting the module or loads on the module in accordance with the generally accepted guidelines for screw connections.
- Secure all screw connections using a suitable chemical screw lock.

### 4.1 Mechanical connection

#### Evenness of the mounting surface

The values apply to the whole mounting surface to which the product is mounted.

Edge length	Permissible unevenness
< 100	< 0.02
> 100	< 0.05

Tab.: Requirements for evenness of the mounting surface (Dimensions in mm)

The linear module may be selectively attached to the body or the carriage..

Similarly, the structure may be optionally attached to the end carriage or the base body.

### 4.2 Pneumatic connection

#### CAUTION

#### Possible damage to the linear module!

If the unit moves too hard into the end position, the linear module may be damaged.

- A linear movement must always be free of impact and bounce.
- For this purpose, carry out sufficient throttling and damping, ▶ 4.5 [24].
- Observe the specifications in the catalog data sheet.

**CAUTION**

**Risk of damage to the linear module when changing pressure medium.**

The unit must not under any circumstances be operated with oiled air before operation with unoiled air (washing out of factory lubrication).

**NOTE**

- Use connecting wires with the same cross-section as the connection thread or larger.
- Observe the requirements for the air supply ▶ 3 [16].

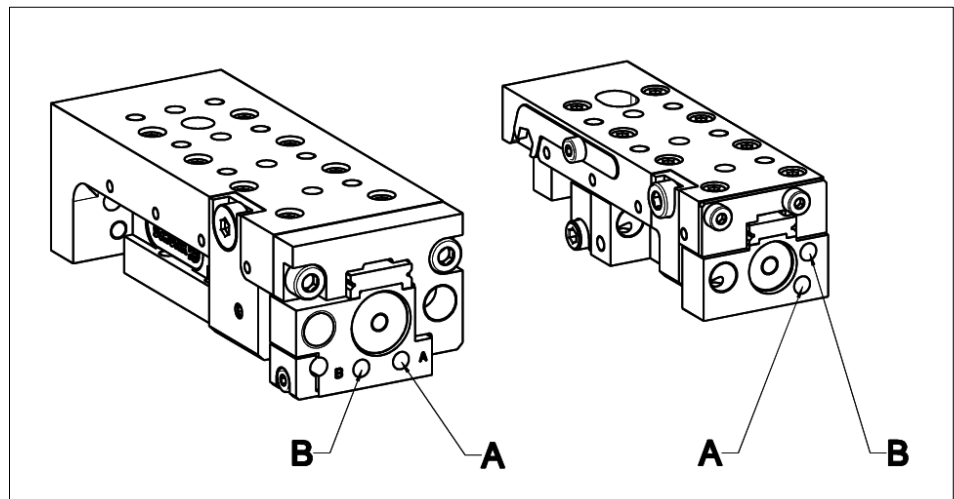

Compressed air connection CLM 08, 10

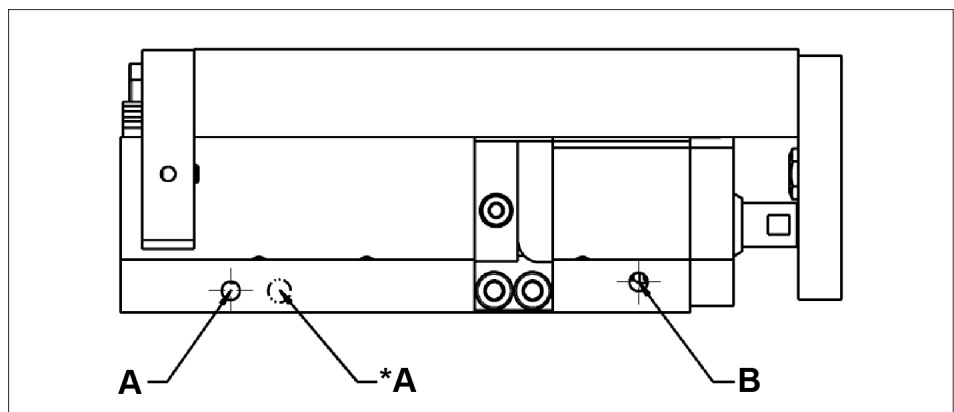

Compressed air connection CLM 25 – 100 (\* for CLM 25: connection opposite)

Air connection	CLM					
	08	10	25	50	100	200
A	M3	M3	M5	M5	M5	G1/8"
B	M3	M3	M5	M5	M5	G1/8"

## 4.3 Adjust stroke, sensors and damping

### 4.3.1 Endlagen – Sets CLM 08

The following components are available for stroke limiting, shock absorption and monitoring of the end positions:

- End stop without sensor system LMAS 08-KT
- End stop with sensor system NIA 50-KT

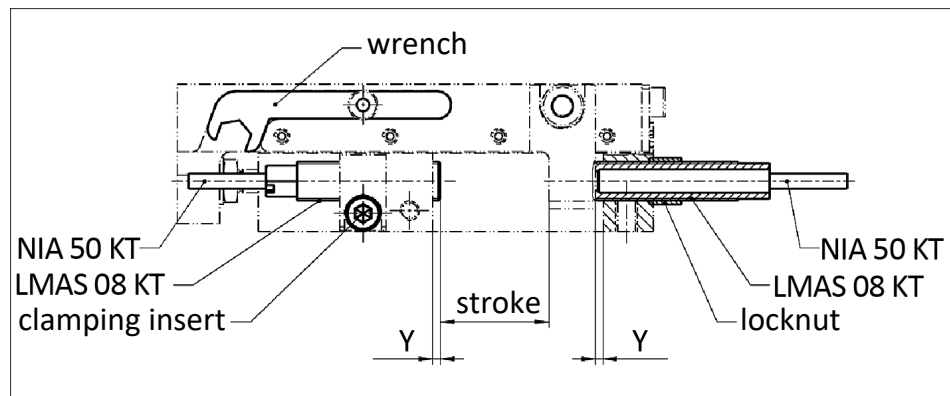

Linear module end positions – Set CLM 08

Size	Min. distance Y [mm]
CLM 08	1.0

### CAUTION

#### Material damage due to erroneous settings!

- Do not fall below minimum distance Y.
- The end stop is the respective shock absorber on both sides; the inside of the product must not hit the end stop.

#### Stroke adjustment/ sensor adjustment

Set end position "linear module extended":

1. Loosen the attachment screw.
2. Set the end stop to the desired stroke with the wrench supplied. **IMPORTANT! Do not fall below minimum distance Y.**
  - ⇒ The optionally integrated sensor moves with the machine and does not need to be readjusted.
3. Tighten the attachment screw.
  - ⇒ Maximum permissible tightening torque: 0.6 Nm

Set analog end position "Linear module retracted".

### 4.3.2 Endlagen – Sets CLM 10 – 25

The following components are available for stroke limiting, shock absorption and monitoring of the end positions:

- Stop screw LMAS (option)
- Shock absorbers (included in the scope of delivery)

- Damping adjustment (included in the scope of delivery)
- Sensors (option)

Subsequent the installation of the end position damping is shown.

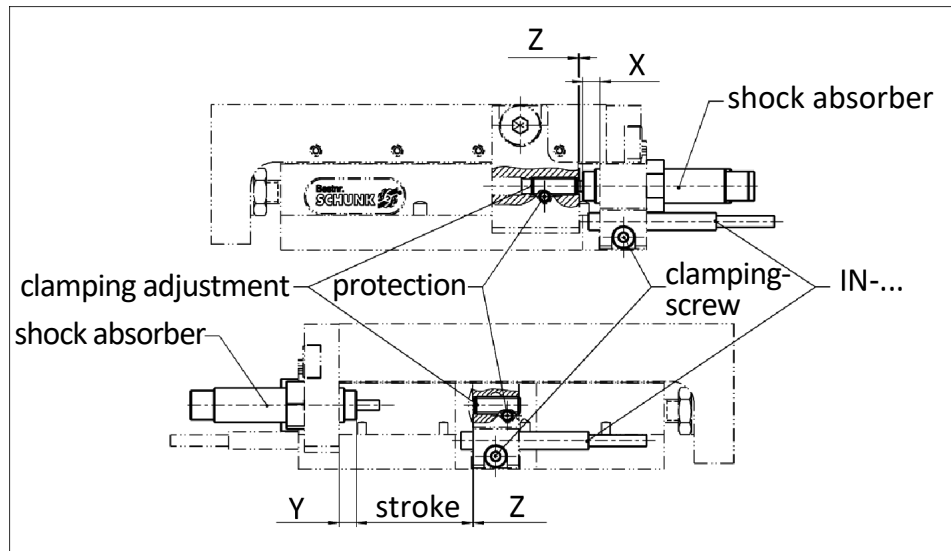

Linear module end positions – Set CLM 10 – 25

Linear module	Damping adjustment range Z [mm]	min. distance X [mm]	min. distance Y [mm]
CLM 10	0...2	3.4	3.0
CLM 25	0...1.3	8	13

### CAUTION

#### Material damage due to erroneous settings!

- Do not fall below minimum distances X and Y.
- The end stop is the respective shock absorber on both sides; the inside of the product must not hit the end stop.

#### Stroke adjustment/ sensor adjustment

1. Loosen the attachment screw.
2. For CLM 10: Loosen counter nut.
3. Set shock absorber and proximity switch IN to the desired stroke. **IMPORTANT! Do not fall below minimum distances X and Y.**
4. For CLM 10: Tighten counter nut.
5. Tighten the attachment screw.
  - ⇒ Observe the tightening torque, see following table.

Size	Max. permissible screw tightening torque for strength class 8.8 [Nm]
CLM 10	0.15
CLM 25	<ul style="list-style-type: none"> <li>• 1.3 – Shock absorber stop LMST-25-KT</li> <li>• 0.3 – Proximity switch IN 40</li> </ul>

### Damping adjustment

To adapt the damping characteristic of the apparent kinetic energy, the damper stroke and thus the characteristics can be adjusted.

1. Release the lock.
2. Set the setscrew to the desired dimension.  
**IMPORTANT! Observe adjustment range Z.**
3. Secure the setscrew again.

### 4.3.3 Endlagen – Sets CLM 50 – 200

The following components are available for stroke limiting, shock absorption and monitoring of the end positions:

- Stop screw LMAS (option)
- Shock absorber – stop LMST (included in the scope of delivery)
- Damping adjustment LMD (included in the scope of delivery)
- Sensors IN (option)

In the following, the installation of LMST-... and IN-... is shown:

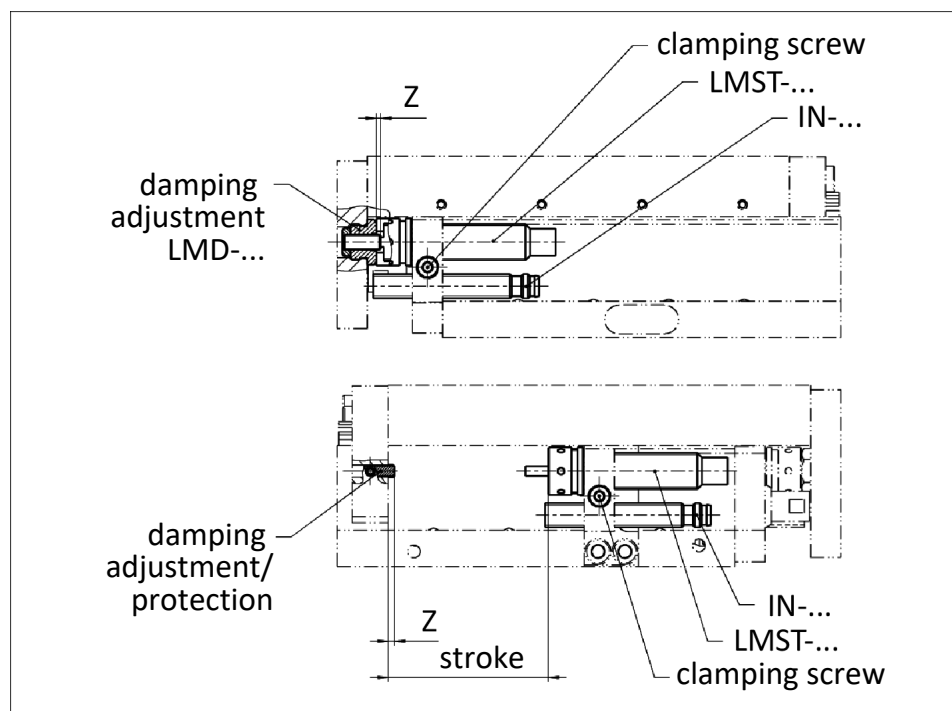

Linear module end positions – Set CLM 50 – 200

### Stroke adjustment/ sensor adjustment

1. Loosen the attachment screw.
2. Set shock absorber stop LMST and proximity switch IN to desired stroke.
3. Tighten the attachment screw.  
⇒ Observe the tightening torque, see following table.

Size	Max. permissible screw tightening torque for strength class 8.8 [Nm]
CLM 50	<ul style="list-style-type: none"> <li>• 1.3 – Shock absorber stop LMST-50-KT</li> <li>• 0.3 – Proximity switch IN 40</li> </ul>
CLM 100	3.0
CLM 200	5.9

The maximum permissible values for end position adjustment can be found in the catalog.

### Damping adjustment

To adapt the damping characteristic of the apparent kinetic energy, the damper stroke and thus the characteristics can be adjusted.

1. Release the lock of the setscrew.
2. Adjust the damping adjustment setscrew to the desired dimension. **IMPORTANT! Observe adjustment range Z!**
3. Secure the setscrew again.

Size	Damping adjustment range Z [mm]
CLM 50	0...+1.8
CLM 100	-0.6...+2.4
CLM 200	-1.8...+1.8

## 4.4 Setting the speed

### CAUTION

#### Material damage due to erroneous settings!

If the end position is approached too hard, the product may be damaged.

- Adjust exhaust throttle valve and shock absorber so that the movement is braked smoothly.

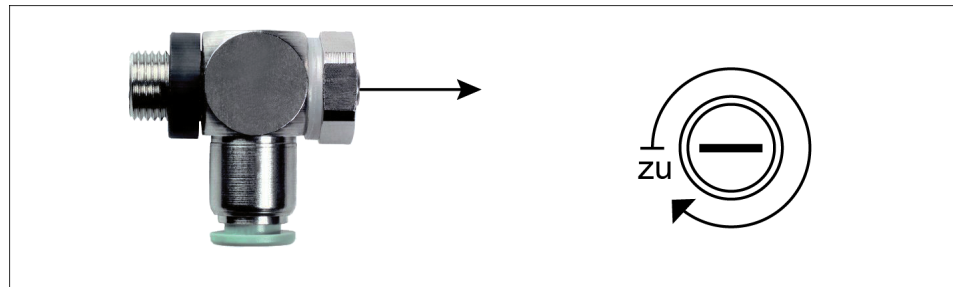

1. Close exhaust throttle valve completely.

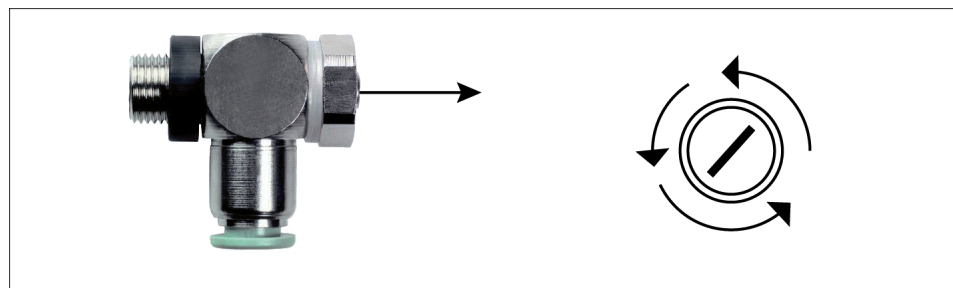

2. Open exhaust throttle valve until the product starts to move.
3. Continue to open the exhaust throttle valve incrementally until the movement decelerates smoothly.
  - ⇒ If the speed is too low, the product will brake too soon and the end position will be reached too slowly.
  - ⇒ If the speed is too high, the product will impact against the end position and the shock absorber will be overloaded.

### NOTE

A smooth motion may also be too slow in many use-cases. Further settings can be made via the shock absorbers, ▶ 4.5 [ 24].

### 4.5 Adjustment of the shock absorber stroke

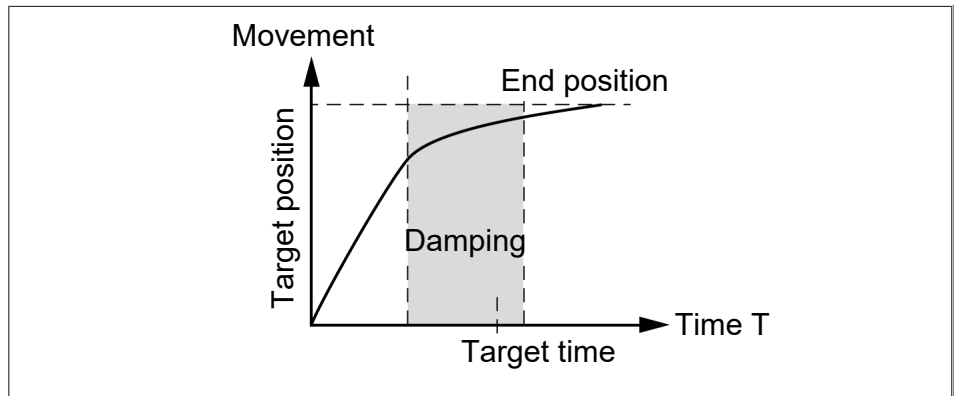

The shock absorber stroke is too long and the end position is reached too slowly.

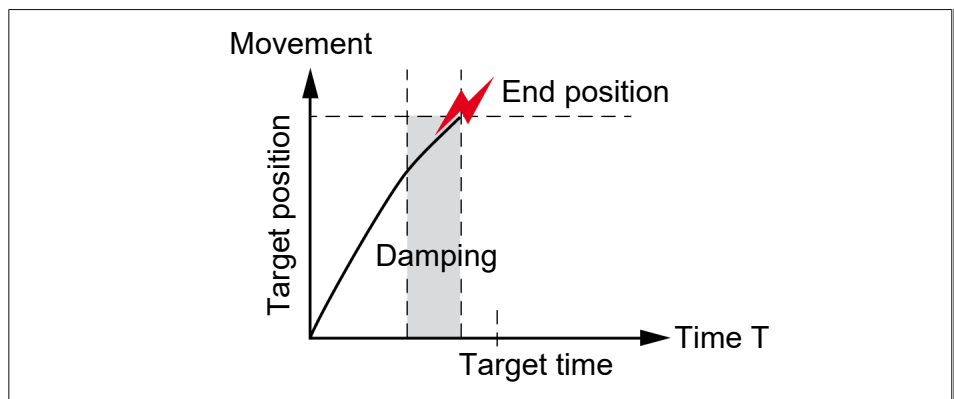

The shock absorber stroke is too short and the unit arrives in the end position too abruptly.

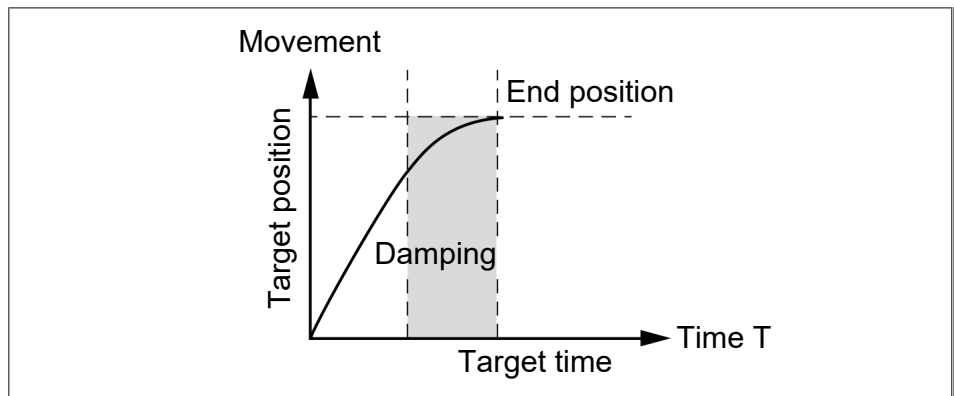

Optimal shock absorber stroke.



## 4.6 Mounting the rod lock

### CAUTION

#### Damage to the rod lock due to incorrect actuation / overload!

- The rod lock may only be triggered and unlocked when the product has been shut down.
- See the data on static holding force in the catalog. The forces occurring in a clamped condition must not exceed the holding force.
- In the event of a dynamic load or overload (e.g. drop in pressure during movement), the clamping cartridge must be checked and replaced if necessary.



Assembly of ASP rod lock

### ⚠ WARNING

The rod lock is not a safety component for personal protection in the sense of the Machine Directive.

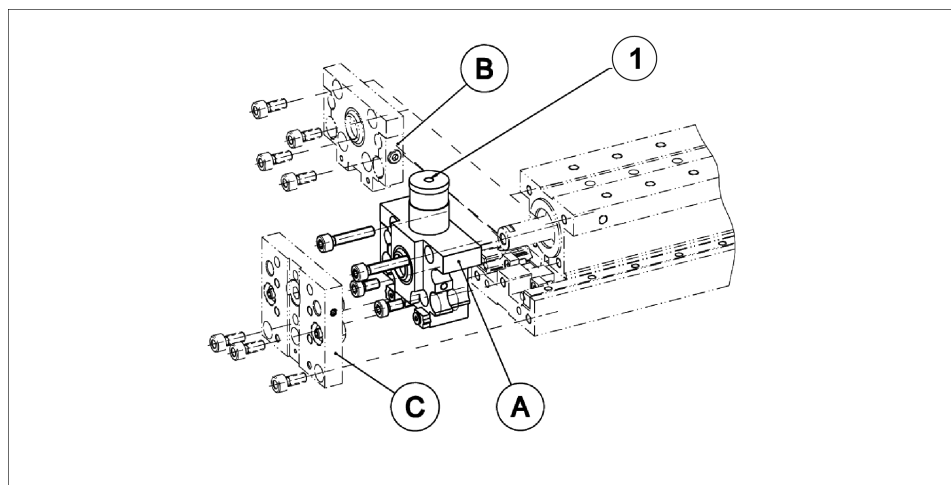

1. Disassemble face plate I (C) and cover plate I (B)
2. Install the completely installed rod lock (A).
3. Grease wiper ring ▶ 7 [ 28]  
Cover plate (B) is no longer required.
4. Install face plate I (C).
5. Removing screw from air connection (1)  
⇒ Clamping is active and must be released by the appropriate air pressure.

## 5 Commissioning

- Check the technical specifications ▶ 3 [16].
- Do not use the product until trouble-free operation has been checked, taking all permissible operating parameters into account.
- The speed of movement must be regulated via throttle check valves ▶ 4.2 [17]. The speed is always set so that it starts at a low speed and increases to a higher speed until the desired operating speed is reached.

### **CAUTION**

#### **Risk of mechanical damage of the product!**

The product must always be adjusted so that no mechanical impacts are produced when reaching the end position.

---

## 6 Troubleshooting

### 6.1 Module does not move

Possible cause	Corrective action
Pressure drops below minimum.	Check air supply. ▶ 4.2 [17]
Compressed air lines switched.	Check compressed air lines. ▶ 4.2 [17]

### 6.2 Endlagensignal nicht vorhanden

Possible cause	Corrective action
Sensor set to the stop inaccurately	Adjust the sensor, ▶ 4.3 [19].
Proximity switch defective or set incorrect.	Change sensor.
Cable breakage.	Replacing the sensor cable.

### 6.3 Linear module proposes at the end positions

Possible cause	Corrective action
Damping wrong adjustet.	Adjust stop screw.
Shock absorber defective.	Change the shock absorber.
Stroke speed too high.	Check / reduce stroke speed with ventilation valves. Change defective exhaust ait throttle if necessary.

### 6.4 Nutzlast schwingt in der Endlage

Possible cause	Corrective action
Stroke speed too high.	Check / reduce stroke speed with ventilation valves. Change defective exhaust ait throttle if necessary.
Bad damping.	Adjust damping (stop screw). ▶ 4 [17]
Unfavorable installation.	Check construction.
CLM size too small	Use larger CLM size.

## 7 Maintenance and care

### CAUTION

The following recommendations apply to intended use in accordance with the specified operating parameters, operating conditions and settings .

Maintenance work	Maintenance interval
Inspect the shock absorbers	Regularly
Replace shock absorber	every 2 million cycles
Check seals	Regularly
Replace seals	As required

The seals are included in the seal kit

During maintenance, treat all greased areas with lubricant. Thinly apply lubricant with a lint-free cloth. SCHUNK recommends the lubricants listed.

Lubricant point	Lubricant
Seals and sealing surfaces	SCHUNK grease 1
Linear guides	SCHUNK grease 10

Details regarding SCHUNK lubricant designations are available at [schunk.com/lubricants](https://www.schunk.com/lubricants).

The product contains food-compliant lubricants as standard. **The requirements of standard EN 1672-2:2020 are not fully met.**

### NOTE

- Change contaminated food-compliant lubricant.
- Observe information in the safety data sheet from the lubricant manufacturer.

## 7.1 Assembly drawings/spare parts

### 7.1.1 CLM 08

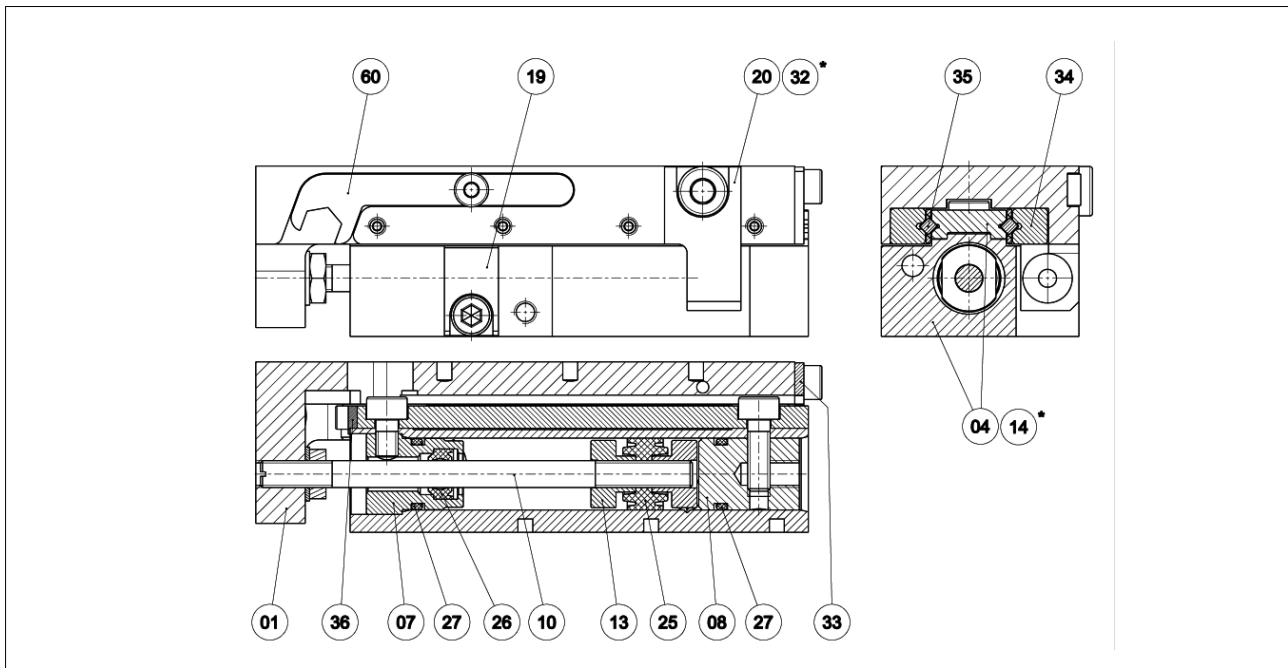

Sectional drawing CLM 08

Seal kits are available as a standardized wearing parts set. All seals are included.

Order Number

- CLMDI 008 ID number0314188

According to the sectional drawing all other wear parts and components are available separately.

#### Wear parts

Item 04\*, 14\*, 25, 26, 27, 34, 35

\* Item 04 (base body) and item 14 (guide rail) only available as pre-assembled assembly.

Order numbers in the following example

Part-No. 1 CLM 08 - H14 - 01

### 7.1.2 CLM 10

Seal kits are available as a standardized wearing parts set. All seals are included.

Order Number

- CLMDI 010 ID number 0314189

Spare part designation of the shock absorbers:

Order Number

- LMST 10-KT, ID number 0314108

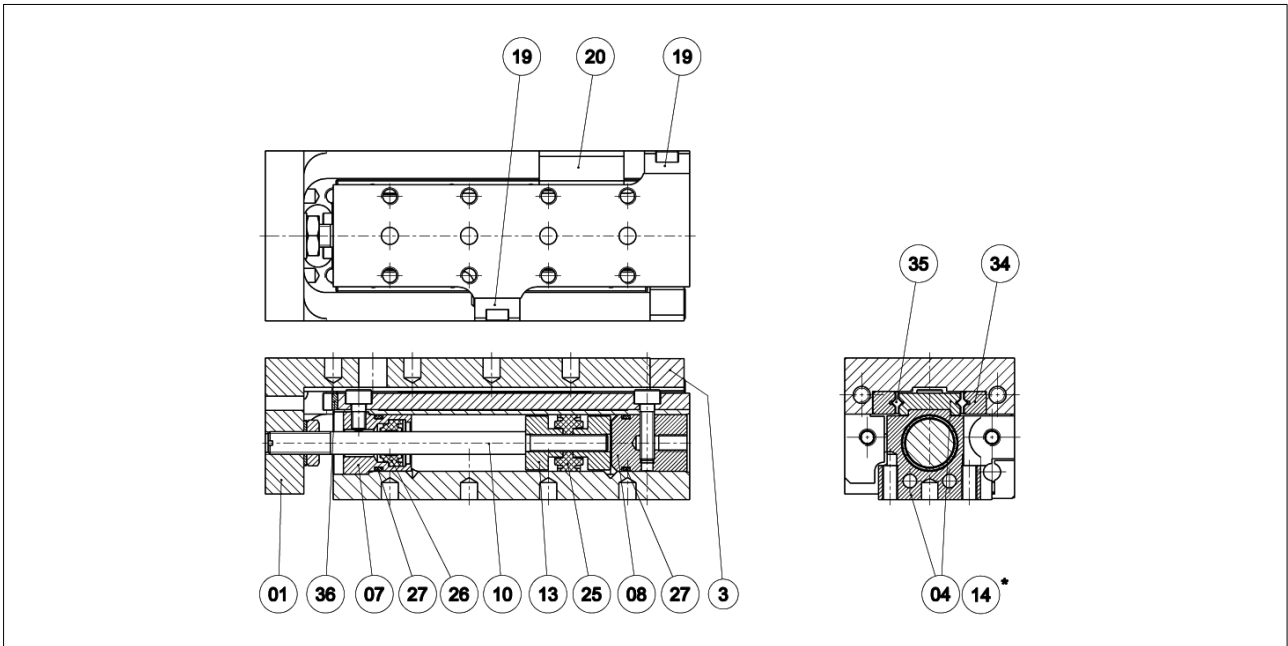

Sectional drawing CLM 10

According to the sectional drawing all other wear parts and components are available separately.

#### Wear parts

Item 04\*, 14\*, 25, 26, 27, 34, 35

\* Item 04 (base body) and item 14 (guide rail) only available as pre-assembled assembly.

Order numbers in the following example

Part-No. 1 CLM 10 – H20 – 01

### 7.1.3 CLM 25

Seal kits are available as a standardized wearing parts set. All seals are included.

Order Number

- CLMDI 025 ID number0314214

Spare part designation of the shock absorbers:

Order Number

- LMST 25-KT, ID number0314164

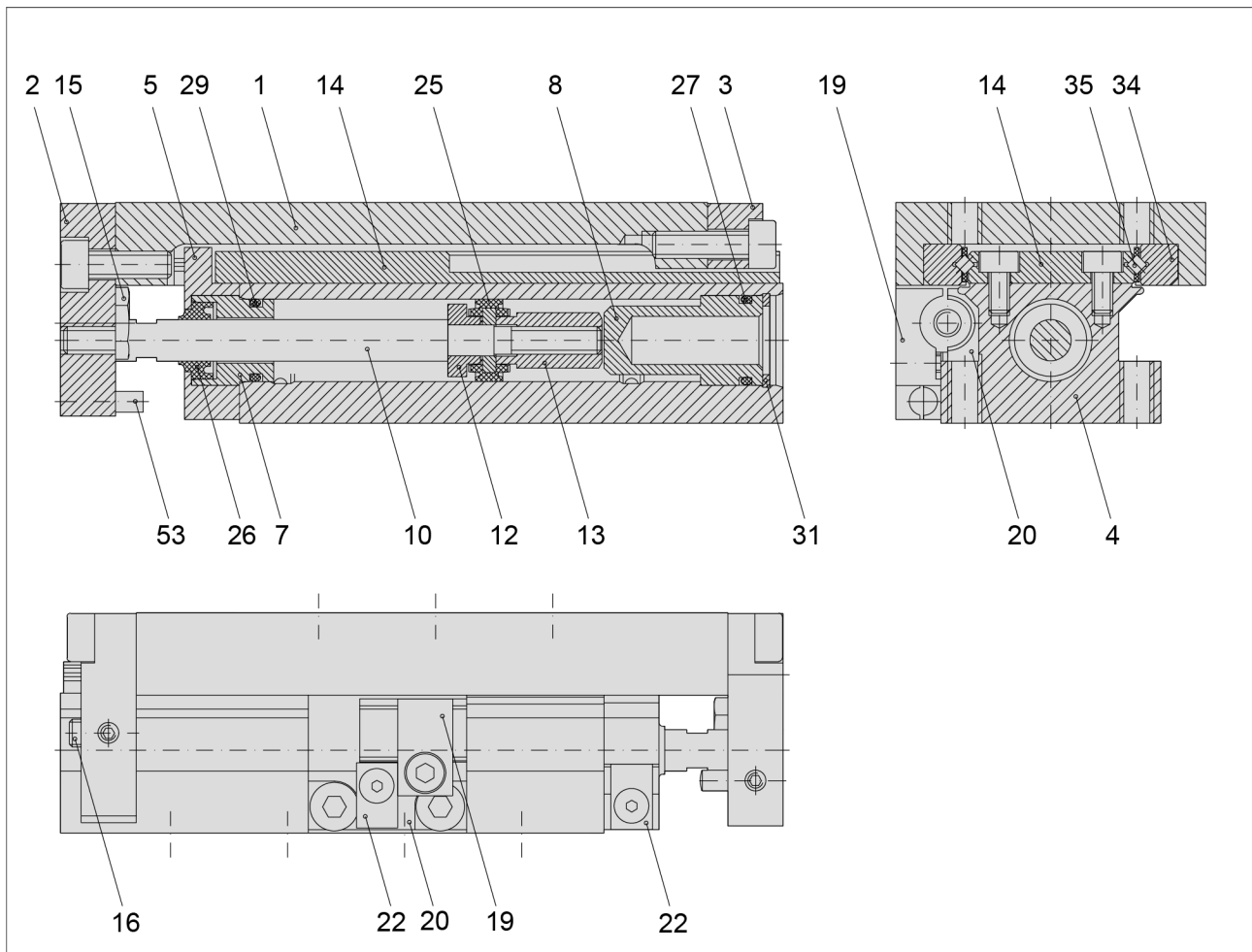

Sectional drawing CLM 25

According to the sectional drawing all other wear parts and components are available separately.

#### Wear parts

Item 14, 25, 26, 27, 29, 34, 35

Order numbers in the following example

Part-No. 1 CLM 25 – H025 – 01

### 7.1.4 CLM 50, 100 and 200

Seal kits are available as a standardized wearing parts set. All seals are included.

Order Number

- CLMDI 050 ID number0314216
- CLMDI 100 ID number0314218
- CLMDI 0200 ID number0314220

Spare part designation of the shock absorbers:

Order Number

- LMST 50-KT, ID number0314166
- LMST 100-KT, ID number0314168
- LMST 200-KT, ID number0314172

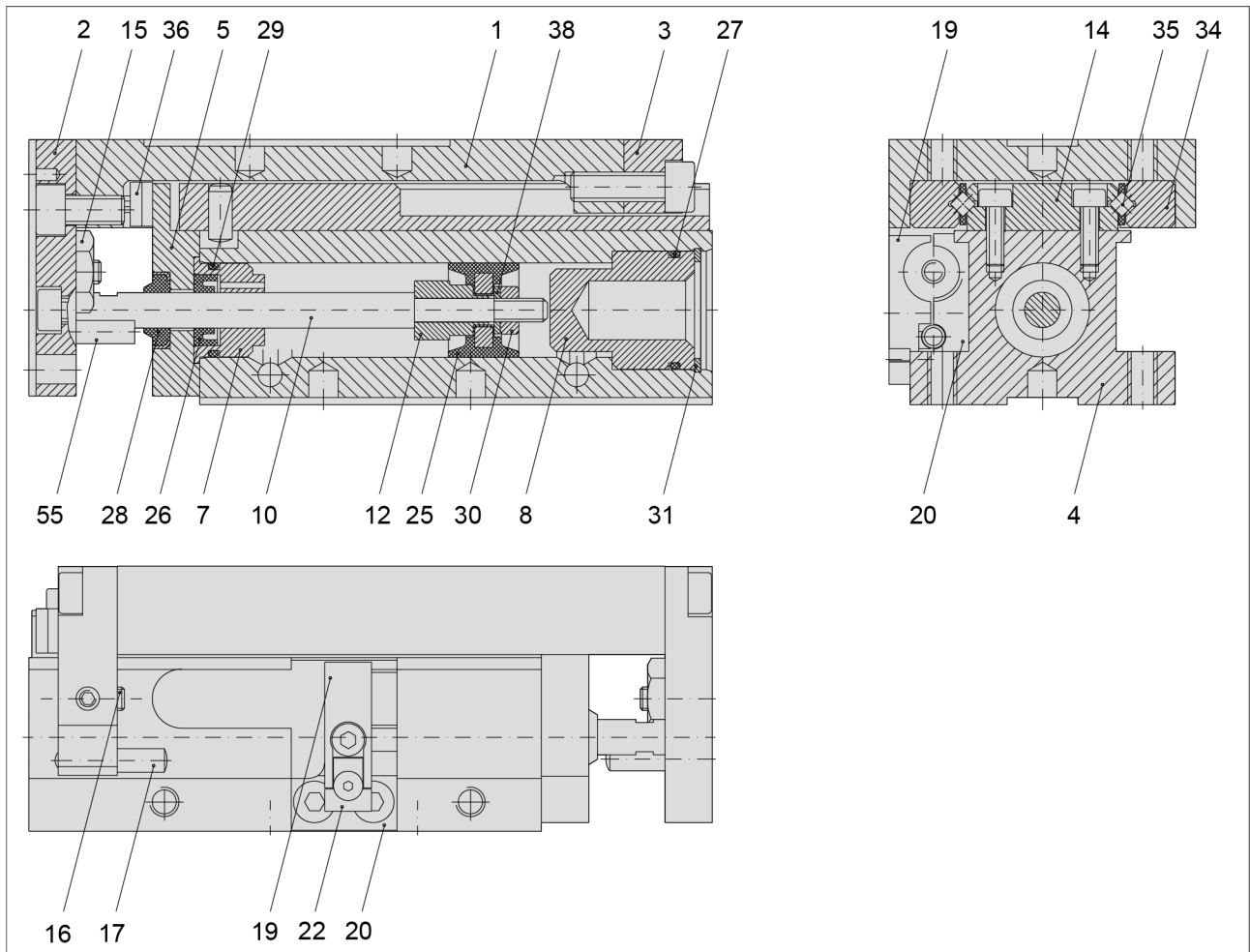

Sectional drawing CLM 50, 100, 200

According to the sectional drawing all other wear parts and components are available separately.

#### Wear parts

Item 14, 26, 27, 28, 29, 34, 35, 38

Order numbers in the following example

Part-No. 1 CLM 100 – H075 – 01



## 8 Translation of the original declaration of incorporation

in terms of the Directive 2006/42/EG, Annex II, Part 1 Section B.

Manufacturer/  
Distributor                      SCHUNK SE & Co. KG  
Toolholding and Workholding | Gripping Technology | Automation  
Technology  
Bahnhofstr. 106 – 134  
D-74348 Lauffen/Neckar

We hereby declare that the partly completed machine described below

Product designation:            Compact Linear Module / CLM /pneumatic  
ID number                         0314000, 0314001, 0314002, 0314005, 0314006, 0314007, 0314035,  
0314036, 0314037, 0314038, 0314039, 0314040, 0314041, 0314042,  
0314043, 0314044, 0314045, 0314046, 0314047, 0314439, 0314440,  
0314442, 0314443, 0314444, 0314446, 0314447

meets the following basic occupational health and safety of the Machinery Directive 2006/42/EC:

No. 1.1.1, No. 1.1.2, No. 1.1.3, No. 1.1.5, No. 1.3.2, No. 1.5.3, No. 1.5.4, No. 1.5.6, No. 1.5.8, No. 1.5.10, No. 1.5.11, No. 1.5.13

The partly completed machinery may not be put into operation until it has been confirmed that the machine into which the partly completed machinery is to be installed complies with the provisions of the Machinery Directive (2006/42/EC). The declaration shall be rendered invalid if modifications are made to the product.

Applied harmonized standards, especially:

EN ISO 12100:2010                Safety of machinery – General principles for design –  
Risk assessment and risk reduction

The special technical documentation according to Annex VII, Part B, belonging to the partly completed machine, has been created.

Person authorized to compile the technical documentation:  
Stefanie Walter, Address: see manufacturer's address

*Signature: see original declaration*

Lauffen/Neckar, February 2024

Dr.-Ing. Manuel Baumeister,  
Head of Systems Engineering,  
Technology & Innovation

## 9 UKCA declaration of incorporation

in accordance with the Supply of Machinery (Safety) Regulations 2008.

Manufacturer/  
Distributor SCHUNK Intec Limited  
Clamping and gripping technology  
3 Drakes Mews, Crownhill  
MK8 0ER Milton Keynes

We hereby declare that on the date of the declaration the following partly completed machine complied with all basic safety and health regulations found in the "Supply of Machinery (Safety) Regulations 2008".

The declaration shall be rendered invalid if modifications are made to the product.

Product designation: Compact Linear Module / CLM / pneumatic  
ID number 0314000, 0314001, 0314002, 0314005, 0314006, 0314007, 0314035,  
0314036, 0314037, 0314038, 0314039, 0314040, 0314041, 0314042,  
0314043, 0314044, 0314045, 0314046, 0314047, 0314439, 0314440,  
0314442, 0314443, 0314444, 0314446, 0314447

The partly completed machine may not be put into operation until it has been confirmed that the machine into which the partly completed machine is to be installed complies with the provisions of the "Supply of Machinery (Safety) Regulations 2008".

Applied harmonized standards, especially:

EN ISO 12100:2010 Safety of machinery – General principles for design –  
Risk assessment and risk reduction

The special technical documentation according to Annex VII, Part B, belonging to the partly completed machine, has been created.

Person authorized to compile the technical documentation:  
Marcel Machado, address: refer to manufacturer's address



Lauffen/Neckar, February 2024

Dr.-Ing. Manuel Baumeister,  
Head of Systems Engineering,  
Technology & Innovation

## 10 Information on the RoHS Directive, REACH Regulation and Substances of Very High Concern (SVHC)

### RoHS Directive

SCHUNK products are classified as "large-scale stationary installations" or as "large-scale stationary industrial tools" within the meaning of Directive 2011/65/EU and its extension 2015/863/EU "on the restriction of the use of certain hazardous substances in electrical and electronic equipment (RoHS)", or fulfill their intended function only as part of one. Therefore products from SCHUNK do not fall within the scope of the directive at this time.

### REACH Regulation

Products from SCHUNK fully comply with the regulations of Regulation (EC) No. 1907/2006 "concerning the Registration, Evaluation, Authorization and Restriction of Chemicals (REACH)" and its amendment 2022/477. SCHUNK attaches great importance to completely avoiding chemicals of concern to humans and the environment wherever possible.

Only in rare exceptional cases do SCHUNK products contain SVHC substances on the candidate list with a mass content above 0.1%. In accordance with Article. 33 (1) of Regulation (EC) No. 1907/2006, SCHUNK complies with its duty to "communicate information on substances in articles" and lists the components concerned and the substances used in an overview that can be viewed at [schunk.com/SVHC](https://schunk.com/SVHC).

*Signature: see original declaration*

Lauffen/Neckar, February 2024

Dr.-Ing. Manuel Baumeister,  
Head of Systems Engineering,  
Technology & Innovation



**SCHUNK SE & Co. KG**  
Toolholding and Workholding | Gripping Technology |  
Automation Technology

Bahnhofstr. 106 – 134  
D-74348 Lauffen/Neckar  
Tel. +49-7133-103-0  
info@de.schunk.com  
schunk.com

Folgen Sie uns | *Follow us*



Wir drucken nachhaltig | *We print sustainable*