

Assembly and Operating Manual

MTB SG-JGP-P

Application kit

Translation of Original Operating
Manual

Imprint

Copyright:

This manual is protected by copyright. The author is SCHUNK SE & Co. KG.
All rights reserved.

Technical changes:

We reserve the right to make alterations for the purpose of technical improvement.

Document number: 1495002

Version: 05.00 | 16/05/2024 | en

Dear Customer,

Thank you for trusting our products and our family-owned company, the leading technology supplier of robots and production machines.

Our team is always available to answer any questions on this product and other solutions. Ask us questions and challenge us. We will find a solution!

Best regards,

Your SCHUNK team

Customer Management

Tel. +49-7133-103-2503

Fax +49-7133-103-2189

cmg@de.schunk.com



Please read the operating manual in full and keep it close to the product.

Table of Contents

1 General	5
1.1 About this manual.....	5
1.1.1 Presentation of Warning Labels	5
1.1.2 Definition of Terms	5
1.1.3 Symbol definition.....	6
1.1.4 Applicable documents	6
1.1.5 Sizes.....	6
1.2 Warranty	7
1.3 Scope of delivery.....	7
1.4 Accessories	7
2 Basic safety notes	8
2.1 Intended use.....	8
2.2 Constructional changes.....	8
2.3 Spare parts	9
2.4 Gripper fingers	9
2.5 Ambient conditions and operating conditions	9
2.6 Personnel qualification	9
2.7 Personal protective equipment	10
2.8 Notes on safe operation.....	11
2.9 Transport.....	11
2.10 Malfunctions.....	12
2.11 Disposal	12
2.12 Fundamental dangers	12
2.12.1 Protection during handling and assembly	13
2.12.2 Protection during commissioning and operation	13
2.12.3 Protection against dangerous movements	14
2.13 Notes on particular risks	14
3 Technical data	16
4 Design and description	18
4.1 Design	18
4.2 Description	18
4.3 Display.....	19
5 Assembly.....	20
5.1 Installing and connecting	20
5.2 Mechanical connection.....	21
5.3 Electrical connection.....	22
5.3.1 Control of the digital signals.....	23

5.4 Attach compressed air hose and cable	24
6 Start-up	25
7 Troubleshooting.....	26
7.1 Electrical signals are not transmitted	26
7.2 Product does not move.....	26
8 Maintenance	27
8.1 Assembly drawing	28
9 Translation of the original declaration of incorporation	29
10 UKCA declaration of incorporation	30
11 Information on the RoHS Directive, REACH Regulation and Substances of Very High Concern (SVHC)	31

1 General

1.1 About this manual

This manual contains important information for a safe and appropriate use of the product.

This manual is an integral part of the product and must be kept accessible for the personnel at all times.

Before starting work, the personnel must have read and understood this operating manual. Prerequisite for safe working is the observance of all safety instructions in this manual.

In addition to these instructions, the documents listed under ▶ 1.1.4 [6] are applicable.

NOTE: The illustrations in this manual are intended to provide a basic understanding and may deviate from the actual version.

1.1.1 Presentation of Warning Labels

To make risks clear, the following signal words and symbols are used for safety notes.



⚠ DANGER

Dangers for persons!

Non-observance will inevitably cause irreversible injury or death.



⚠ WARNING

Dangers for persons!

Non-observance can lead to irreversible injury and even death.



⚠ CAUTION

Dangers for persons!

Non-observance can cause minor injuries.

CAUTION

Material damage!

Information about avoiding material damage.

1.1.2 Definition of Terms

The term "product" replaces the product name on the title page in this manual.

1.1.3 Symbol definition

The following symbols are used in this manual:

■ Prerequisite for an action

1. Action 1

2. Action 2

⇒ Intermediate results

⇒ Final results

▶ 1.1.3 [📄 6]: chapter number and [page number] in hyperlinks

1.1.4 Applicable documents

- General terms of business *
- Catalog data sheet of the purchased product *
- Assembly and operating manual of the gripper JGP-P *
- Assembly and operating manual of the sensor MMS 22-PI1 *
- "SCHUNK Application Kit MTB" software manual for
 - Universal Robots *
 - FANUC *
 - ABB *
- Assembly and operating manuals of the accessories *

The documents labeled with an asterisk (*) can be downloaded from [schunk.com/downloads](https://www.schunk.com/downloads).

1.1.5 Sizes

This operating manual applies to the following sizes:

- MTB SG-JGP-P 80
- MTB SG-JGP-P 100

1.2 Warranty

If the product is used as intended, the warranty is valid for 24 months from the ex-works delivery date under the following conditions:

- Observe the maximum service life
- Observe the ambient conditions and operating conditions, ▶ 2.5 [9]
- Observe the specified maintenance intervals, ▶ 8 [27]

Parts touching the workpiece and wear parts are not included in the warranty.

Performance	MTB SG-JGP-P
Cycles, maximum number *	10 [mil.]

Tab.: Performance

*) A cycle consists of a complete gripping process: "Open gripper" and "Close gripper".

1.3 Scope of delivery

The scope of delivery includes

- Application kit MTB SG-JGP-P in the ordered model
- Safety information (product-specific instructions available online)

1.4 Accessories

A wide range of accessories are available for this product

For information regarding which accessory articles can be used with the corresponding product variants, see catalog data sheet.

Robot connection package

Robot connection packages enable quick assembly and commissioning of the product on the robot.

Content:

- ISO flange
- Velcro strips
- Connection cables
- Compressed air hose
- USB stick
- Screws
- Cylindrical pin

ID: 1490834

2 Basic safety notes

2.1 Intended use

The product is designed for loading and unloading machines and is intended for use with the following robots:

- UR: e-Series
 - TM: TM-Series
 - OMRON: TM-Series
 - FANUC: CRX-Series
 - Doosan: M-, A-, H-Series
 - ABB: CRB15000.
- The product may only be used within the scope of its technical data, ▶ 3 [16].
 - The product is intended for installation in a machine/ automated system. The applicable guidelines for the machine/ automated system must be observed and complied with.
 - The product is intended for industrial use.
 - The product is not suitable for operation without separating protective equipment, e.g. human-robot collaboration (HRC). The product may only be operated with suitable protective measures, e.g. protective fence, etc.
 - In a risk assessment, the owner must identify additional hazards arising from the specific working conditions at the place of use of the product. Process sequences between the robot and the processing machine must be analyzed and any necessary protective measures implemented.
 - Appropriate use of the product includes compliance with all instructions in this manual.
 - Any utilization that exceeds or differs from the appropriate use is regarded as misuse.

2.2 Constructional changes

Implementation of structural changes

Modifications, changes or reworking, e.g. additional threads, holes, or safety devices, can damage the product or impair its functionality or safety.

- Structural changes should only be made with the written approval of SCHUNK.

2.3 Spare parts

Use of unauthorized spare parts

Using unauthorized spare parts can endanger personnel and damage the product or cause it to malfunction.

- Use only original spare parts or spares authorized by SCHUNK.

2.4 Gripper fingers

Requirements of gripper fingers

Accumulated energy can make the product unsafe and risk the danger of serious injuries and considerable material damage.

- Execute the gripper fingers in such a way that the product reaches either the "open" or "closed" position in a de-energized state.
- Only change gripper fingers if no residual energy can be released.
- Make sure that the product and the top jaws are a sufficient size for the application.

2.5 Ambient conditions and operating conditions

Required ambient conditions and operating conditions

Incorrect ambient and operating conditions can make the product unsafe, leading to the risk of serious injuries, considerable material damage and/or a significant reduction to the product's life span.

- Make sure that the product is used only in the context of its defined application parameters, ▶ 3 [16].

2.6 Personnel qualification

Inadequate qualifications of the personnel

If the personnel working with the product is not sufficiently qualified, the result may be serious injuries and significant property damage.

- All work may only be performed by qualified personnel.
- Before working with the product, the personnel must have read and understood the complete assembly and operating manual.
- Observe the national safety regulations and rules and general safety instructions.

The following personal qualifications are necessary for the various activities related to the product:

Trained electrician	Due to their technical training, knowledge and experience, trained electricians are able to work on electrical systems, recognize and avoid possible dangers and know the relevant standards and regulations.
Qualified personnel	Due to its technical training, knowledge and experience, qualified personnel is able to perform the delegated tasks, recognize and avoid possible dangers and knows the relevant standards and regulations.
Instructed person	Instructed persons were instructed by the operator about the delegated tasks and possible dangers due to improper behaviour.
Service personnel of the manufacturer	Due to its technical training, knowledge and experience, service personnel of the manufacturer is able to perform the delegated tasks and to recognize and avoid possible dangers.

2.7 Personal protective equipment

Use of personal protective equipment

Personal protective equipment serves to protect staff in the event of a danger that may interfere with their health or safety at work.

- When working on and with the product, observe the occupational health and safety regulations and wear the required personal protective equipment.
- Observe the valid safety and accident prevention regulations.
- Wear protective gloves to guard against sharp edges and corners and rough surfaces.
- Wear heat-resistant protective gloves when handling hot surfaces.
- Wear protective gloves and safety goggles when handling hazardous substances.
- Wear close-fitting protective clothing and place a hairnet over long hair when dealing with moving components.
- Wear hearing protection in case of increased noise level.

2.8 Notes on safe operation

An incorrect manner of working can make the product unsafe and risks serious injuries and considerable material damage.

- Avoid any manner of working that may interfere with the function and operational safety of the product.
- Use the product as intended.
- Observe the safety notes and assembly instructions.
- Do not expose the product to any corrosive media. Products for special ambient conditions are excluded.
- Rectify malfunctions as soon as they occur.
- Observe the care and maintenance instructions.
- Observe the information on the safety data sheets of the additives and lubricants.
- Observe the current safety, accident prevention, and environmental protection regulations for the application field of the product.

2.9 Transport

Handling during transport

Incorrect handling during transport may impair the product's safety and cause serious injuries and considerable material damage.

- When handling heavy weights, use lifting equipment to lift the product and transport it by appropriate means.
- Secure the product against falling during transportation and handling.
- Stand clear of suspended loads.

2.10 Malfunctions

Behavior in case of malfunctions

- Immediately remove the product from operation and report the malfunction to the responsible departments/persons.
- Order appropriately trained personnel to rectify the malfunction.
- Do not recommission the product until the malfunction has been rectified.
- Test the product after a malfunction to establish whether it still functions properly and no increased risks have arisen.

2.11 Disposal

Handling of disposal

The incorrect handling of disposal may impair the product's safety and cause serious injuries as well as considerable material and environmental harm.

- Follow local regulations on dispatching product components for recycling or proper disposal.

2.12 Fundamental dangers

General

- Observe safety distances.
- Never deactivate safety devices.
- Before commissioning the product, take appropriate protective measures to secure the danger zone.
- Disconnect power sources before installation, modification, maintenance, or calibration. Ensure that no residual energy remains in the system.
- If the energy supply is connected, do not move any parts by hand.
- Do not reach into the open mechanism or movement area of the product during operation.

2.12.1 Protection during handling and assembly

Incorrect handling and assembly

Incorrect handling and assembly may impair the product's safety and cause serious injuries and considerable material damage.

- Have all work carried out by appropriately qualified personnel.
- For all work, secure the product against accidental operation.
- Observe the relevant accident prevention rules.
- Use suitable assembly and transport equipment and take precautions to prevent jamming and crushing.

Incorrect lifting of loads

Falling loads may cause serious injuries and even death.

- Stand clear of suspended loads and do not step into their swiveling range.
- Never move loads without supervision.
- Do not leave suspended loads unattended.

2.12.2 Protection during commissioning and operation

Falling or violently ejected components

Falling and violently ejected components can cause serious injuries and even death.

- Take appropriate protective measures to secure the danger zone.
- Never step into the danger zone during operation.

2.12.3 Protection against dangerous movements

Unexpected movements

Residual energy in the system may cause serious injuries while working with the product.

- Switch off the energy supply, ensure that no residual energy remains and secure against inadvertent reactivation.
- Never rely solely on the response of the monitoring function to avert danger. Until the installed monitors become effective, it must be assumed that the drive movement is faulty, with its action being dependent on the control unit and the current operating condition of the drive. Perform maintenance work, modifications, and attachments outside the danger zone defined by the movement range.
- To avoid accidents and/or material damage, human access to the movement range of the machine must be restricted. Limit/prevent accidental access for people in this area due through technical safety measures. The protective cover and protective fence must be rigid enough to withstand the maximum possible movement energy. EMERGENCY STOP switches must be easily and quickly accessible. Before starting up the machine or automated system, check that the EMERGENCY STOP system is working. Prevent operation of the machine if this protective equipment does not function correctly.

2.13 Notes on particular risks



⚠ WARNING

Risk of injury from objects falling and being ejected!

Falling and ejected objects during operation can lead to serious injury or death.

- Take appropriate protective measures to secure the danger zone.



⚠ WARNING

Risk of injury due to unexpected movements!

If the power supply is switched on or residual energy remains in the system, components can move unexpectedly and cause serious injuries.

- Before starting any work on the product: Switch off the power supply and secure against restarting.
- Make sure, that no residual energy remains in the system.

**⚠ WARNING****Risk of injury from crushing and impacts!**

Serious injury could occur during movement of the base jaw, due to breakage or loosening of the gripper fingers or if the workpiece is lost.

- Wear suitable protective equipment.
- Do not reach into the open mechanism or the movement area of the product.

**⚠ WARNING****Risk of injury from sharp edges and corners!**

Sharp edges and corners can cause cuts.

- Use suitable protective equipment.

**⚠ CAUTION****Hearing damage due to noise!**

The noise occurring in the work area can cause hearing damage.

- Wear hearing protection during work that generates a particularly high noise level.

3 Technical data

Designation	MTB SG-JGP-P
Pressure medium	Compressed air, compressed air quality according to ISO 8573-1:2010 [3:4:3]
Nominal operating pressure [bar]	6
Minimum pressure [bar]	2.5
Max. pressure [bar]	7
Pressure range for air purge [bar]	0.5 – 1
Supply voltage [VDC]	24
Min. [VDC]	21.6
Max. [VDC]	26.4
Maximum current input [mA]	500
Nominal current [mA]	170

More technical data is included in the catalog data sheet. Whichever is the latest version.

Ambient conditions and operating conditions

Designation	MTB SG-JGP-P
Ambient temperature [°C]	
min.	+5
max.	+50
Protection class IP	
– Gripper	40
– Valve box	67
Noise emission [dB(A)]	
– Gripper	≤70
– Blow-off nozzle	>70

Auxiliary materials and lubricants used

Component	Manufacturer	Designation Lubricant/ Auxiliary material
Lubricant on the valves	TECNOLUBESEAL SRL, Via G. Galilei, 7 I-37029 San Pietro in Cariano VR	UNIFLOR 8512S-FG
Seals, valve box	Bremer & Leguil GmbH Am Burgacker 30 - 42 47051 Duisburg info@bremer-leguil.de www.bremer-leguil.de	SCHUNK grease 1
Gripper JGP-P	see Assembly and operating manual of the gripper	

Details regarding SCHUNK lubricant designations are available at schunk.com/lubricants.

The product contains food-compliant lubricants as standard.
The requirements of standard EN 1672-2:2020 are not fully met.

NOTE

- Change contaminated food-compliant lubricant.
- Observe information in the safety data sheet from the lubricant manufacturer.

4 Design and description

4.1 Design

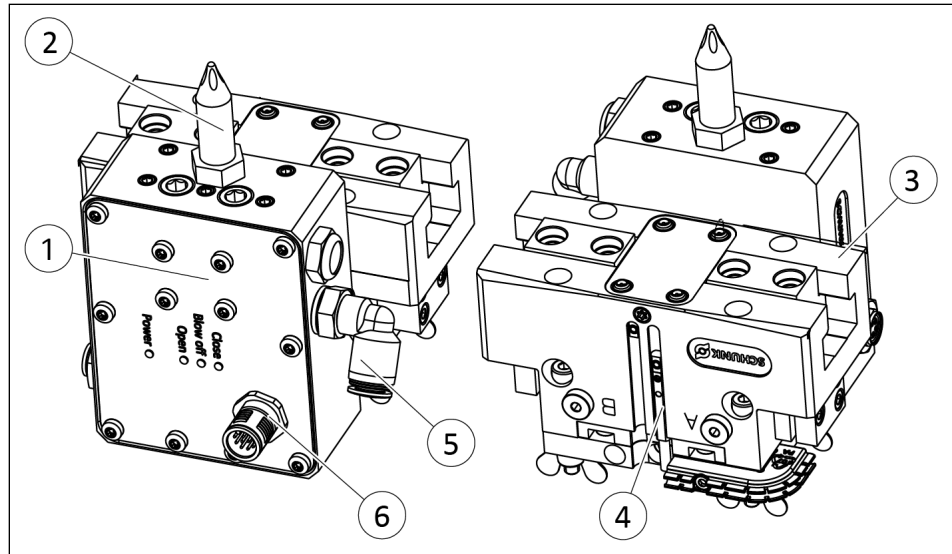

Design Application kit MTB SG-JGP-P

1	Valve box
2	Blow-off nozzle
3	Gripper JGP-P
4	Sensor
5	Plug connector compressed air connection, hose \varnothing 6 mm
6	M12 plug, A-coded, 12-pin, voltage supply and control

4.2 Description

Application kits enable automated machine loading.

The valve box and the sensor are pre-assembled on the product. Gripper fingers are not included in the scope of delivery and are optionally available.

Compressed air and electrical control lines are routed along the robot arm to the gripper and valve box. It is possible to control the valves via the robot controller and thus open or close the gripper.

An adjustable sensor reports the position (Gripper open or Gripper closed) to the robot controller via two digital outputs. The switching positions of the sensor can be set via the robot controller. For further information, see the corresponding software manual, ▶ 1.1.4 [6].

The outgoing air from the blow-off nozzle can be used to remove chips or coolant from the workpiece.

4.3 Display

The following LEDs are located on the valve box:

Designation	Color	Description
LED "Close"	Orange	<ul style="list-style-type: none"> Lights up when base jaws close.
LED "Blow off"	Orange	<ul style="list-style-type: none"> Lights up when air escapes from the blow-off nozzle.
LED "Open"	Orange	<ul style="list-style-type: none"> Lights up when base jaws open.
LED "Power"	Green	<ul style="list-style-type: none"> Lights up if ready for operation. Does not light up if supply voltage polarity is reversed or voltage is not in the valid range.

5 Assembly

5.1 Installing and connecting



⚠ WARNING

Risk of injury due to unexpected movements!

If the power supply is switched on or residual energy remains in the system, components can move unexpectedly and cause serious injuries.

- Before starting any work on the product: Switch off the power supply and secure against restarting.
- Make sure, that no residual energy remains in the system.

NOTE

- Observe the requirements for the compressed air supply, ▶ 3 [16].
- In case of compressed air loss (cutting off the energy line), the product loses its dynamic effects and does not remain in a secure position.

Overview

-
1. Attach the product to the robot, ▶ 5.2 [21].
 2. Fasten the gripper fingers on the base jaws and, if necessary, to the additional attachment, see the Assembly and Operating Manual for the gripper.
 3. Connect the compressed air hose (Ø 6 mm) to the plug connector (5), ▶ 4 [18].
 4. Insert the voltage supply and control cable onto the connector (6) and screw hand-tight.
 5. Glue in the blow-off nozzle (2) and O-ring with liquid, medium-strength threadlocker (tightening torque 1 Nm).
 6. Mount cable and compressed air hose, ▶ 5.4 [24].

5.2 Mechanical connection

An ISO flange is required to attach the product to the robot. The ISO flange is included in the robot connection package, ▶ 1.4 [7].

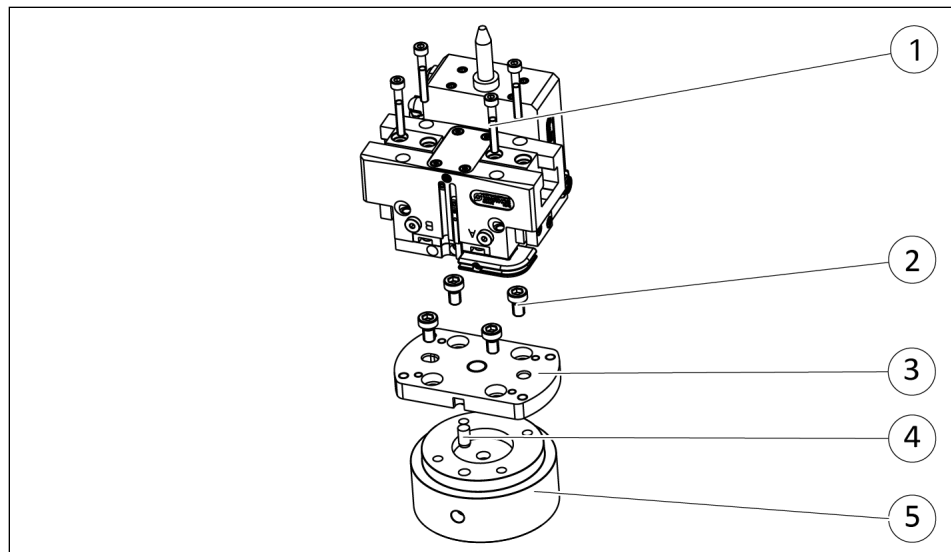

Assembly of the product

Item	Mounting	MTB SG-JGP-P	
		80	100
1	Mounting screw	M4	M5
	Max. depth of engagement from locating surface [mm]	8	9
	Mounting screw according to standard	DIN EN ISO 4762 Max. strength class 8.8	
2	Mounting screw	M6 x 10	
	Tightening torque [Nm]	10	
3	ISO-Flange		
4	Centering pin	6m6 x 14	
5	Robot arm		

Mounting the product on the robot arm

1. Insert centering pin (4) into the robot arm (5).
2. Position ISO flange (3) on robot arm (5).
3. Fasten ISO flange (3) to robot arm (5) using screws (2).
 - ⇒ Observe the tightening torque for the mounting screws.
4. Fasten product to the ISO flange (3) with screws (1).
 - ⇒ Observe the tightening torque, depth of engagement and strength class, if required.

5.3 Electrical connection

On the valve box there is an M12 plug for voltage supply of the sensors and for control of the product.

The corresponding connection cable is included in the robot connection package, ▶ 1.4 [7].

NOTE

For further information about connecting to the robot controller, see the corresponding software manual, ▶ 1.1.4 [6].

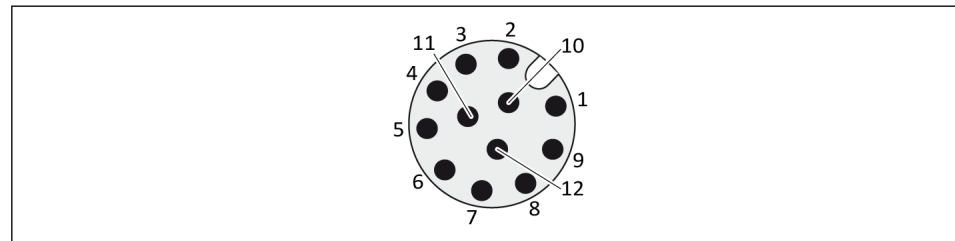

Pin allocation M12 connector, A-coded

No.	Signal
1	+24 VDC
2	GND
3	Sensor gripper, position A
4	Sensor gripper, position B
5	-
6	-
7	Teach function, sensor gripper
8	-
9	Switching, gripper
10	-
11	Release signal
12	Switching blow-off nozzle

5.3.1 Control of the digital signals

Truth table

The truth table shows the actuation of the digital inputs during possible commands by the superordinated control unit.

Power consumption per digital inputs amounts to max. I=10 mA.

Control of gripper, blow-off nozzle

Function	Pin 9 switching, gripper 1	Pin 11 release signal **	Pin 12 switching, blow-off nozzle
Gripper unpowered	*	0	*
The gripper is opening	0	1	*
The gripper is closing	1	1	*
Blow-off nozzle deactivated	*	1	0
Blow-off nozzle activated	*	1	1

Tab.: Control truth table – gripper and blow-off nozzle

* State is not relevant for the described function.

** **Activating pin 11 leads to immediate execution of the function!**

0: max. 12 V (low)

1: min. 18 V (high)

Control of sensor

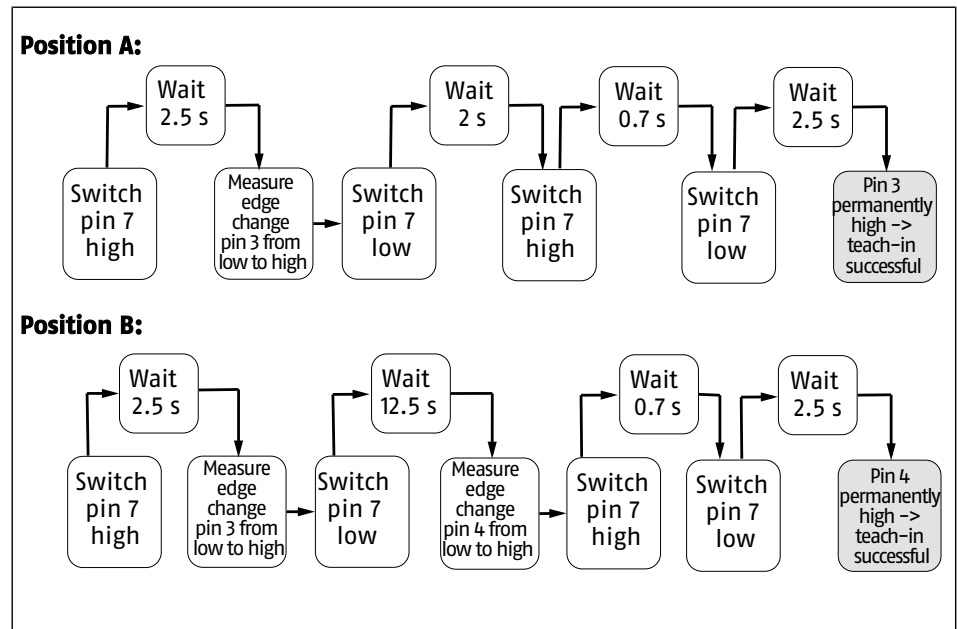

Procedure for sensor teach-in

Note: Repeat the above procedure if other positions require teach-in subsequently. For troubleshooting instructions, see the operating manual for the sensor.

5.4 Attach compressed air hose and cable

CAUTION

Material damage due to incorrect assembly!

Cables and hoses can be damaged by incorrect attachment to the robot.

- Avoid crushing and shearing points.
- Avoid the tensile forces arising.

1. Guide the compressed air hose from the product along the robot arm and fasten it with Velcro strips. In doing so, observe the following:
 - ⇒ If possible, mount with the robot arm fully extended in order to have the maximum hose length.
 - ⇒ Attach the Velcro strips to the center of the robot axes, see markings in the following figure.
 - ⇒ If a Velcro strip is too short and therefore does not fit around the robot axis, two Velcro strips can be joined together.
 - ⇒ Make sure that the hose is not under tension. To do this, leave enough hose after the last Velcro strip so that the last three axes can be turned fully and the hose is not under tension.
2. Guide the cable along the robot in the same way and fasten it with separate Velcro strips. Do not fasten the cable and hose together with Velcro strip.
3. Before commissioning, move the robot axes slowly and check the tensile stresses of the hose and cable.

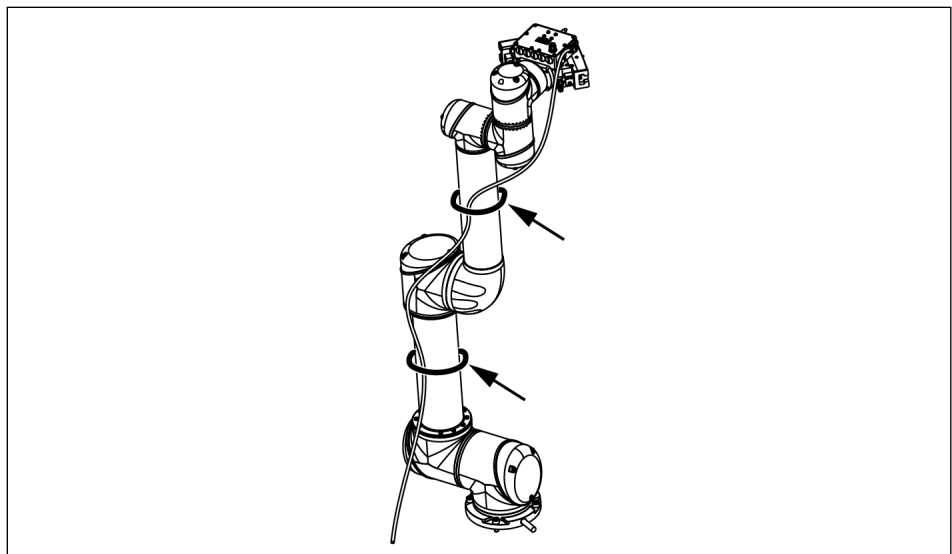

Fastening the compressed air hose with Velcro strips

6 Start-up

SCHUNK provides software modules for commissioning the product on robot controllers.

NOTE

For further information, see the corresponding software manual, ▶ [1.1.4 \[6 \]](#).

7 Troubleshooting

7.1 Electrical signals are not transmitted

Possible cause	Corrective action
Cable connected incorrectly.	Check round connector for correct fit.
Strands swapped.	Check pin allocation.

7.2 Product does not move

Possible cause	Corrective action
Power supply connected incorrectly.	Check the power supply. ▶ 5.3 [📄 22]
Compressed air can escape.	Check compressed air lines.
Supply voltage too low.	Check the compressed air supply.

NOTE

For further information, see the Assembly and Operating Manual for the gripper and sensor.

8 Maintenance



⚠ WARNING

Risk of injury due to unexpected movements!

If the power supply is switched on or residual energy remains in the system, components can move unexpectedly and cause serious injuries.

- Before starting any work on the product: Switch off the power supply and secure against restarting.
- Make sure, that no residual energy remains in the system.



⚠ WARNING

Risk of injury due to contact with lubricants!

Lubricant may cause irritation and allergic reactions if it contacts the skin or eyes.

- Avoid contact between lubricant and skin or eyes.
- Wear safety goggles and protective gloves.
- Observe information on the safety data sheet of the lubricant.

Original spare parts

Use only original spare parts of SCHUNK when replacing spare and wear parts.

Spare parts	ID
Connection cables	1486854
Sensor MMS PI2	1475176
Blow-off nozzle	1550973

Maintenance intervals

Interval (million cycles) for MTB SG-JGP-P	Maintenance work
5	Clean the product dry without a degreasing agent, check for damage and wear.

NOTE

For further information, see the Assembly and Operating Manual for the gripper.

8.1 Assembly drawing

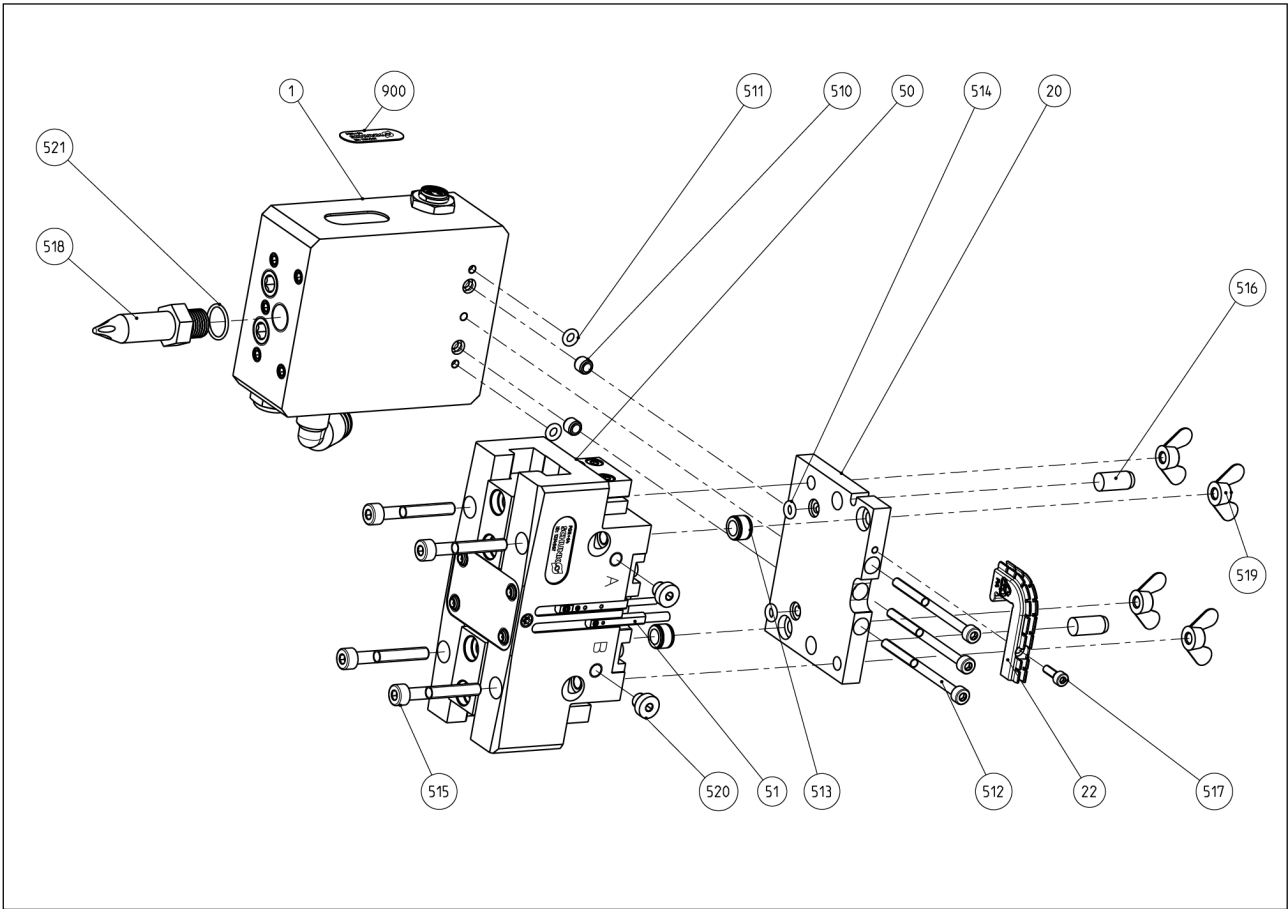

Assembly drawing MTB SG-JGP-P

9 Translation of the original declaration of incorporation

in terms of the Directive 2006/42/EG, Annex II, Part 1 Section B.

Manufacturer/
Distributor SCHUNK SE & Co. KG
Spanntechnik | Greiftechnik | Automatisierungstechnik
Bahnhofstr. 106 – 134
D-74348 Lauffen/Neckar

We hereby declare that the partly completed machine described below

Product designation: Application kit / MTB SG-JGP-P /pneumatic
ID number 1490825, 1490827

meets the following basic occupational health and safety of the Machinery Directive 2006/42/EC:
No. 1.1.1, No. 1.1.2, No. 1.1.3, No. 1.1.5, No. 1.3.2, No. 1.5.3, No. 1.5.4, No. 1.5.6, No. 1.5.8,
No. 1.5.10, No. 1.5.11, No. 1.5.13

The partly completed machinery may not be put into operation until it has been confirmed that the machine into which the partly completed machinery is to be installed complies with the provisions of the Machinery Directive (2006/42/EC). The declaration shall be rendered invalid if modifications are made to the product.

Applied harmonized standards, especially:

EN ISO 12100:2010 Safety of machinery – General principles for design –
Risk assessment and risk reduction

The special technical documentation according to Annex VII, Part B, belonging to the partly completed machine, has been created.

Person authorized to compile the technical documentation:
Stefanie Walter, Address: see manufacturer's address

Signature: see original declaration

Lauffen/Neckar, May 2024

Dr.-Ing. Manuel Baumeister,
Head of Systems Engineering,
Technology & Innovation

11 Information on the RoHS Directive, REACH Regulation and Substances of Very High Concern (SVHC)

RoHS Directive

SCHUNK products are classified as "large-scale stationary installations" or as "large-scale stationary industrial tools" within the meaning of Directive 2011/65/EU and its extension 2015/863/EU "on the restriction of the use of certain hazardous substances in electrical and electronic equipment (RoHS)", or fulfill their intended function only as part of one. Therefore products from SCHUNK do not fall within the scope of the directive at this time.

REACH Regulation

Products from SCHUNK fully comply with the regulations of Regulation (EC) No. 1907/2006 "concerning the Registration, Evaluation, Authorization and Restriction of Chemicals (REACH)" and its amendment 2022/477. SCHUNK attaches great importance to completely avoiding chemicals of concern to humans and the environment wherever possible.

Only in rare exceptional cases do SCHUNK products contain SVHC substances on the candidate list with a mass content above 0.1%. In accordance with Article. 33 (1) of Regulation (EC) No. 1907/2006, SCHUNK complies with its duty to "communicate information on substances in articles" and lists the components concerned and the substances used in an overview that can be viewed at schunk.com/SVHC.

Signature: see original declaration

Lauffen/Neckar, May 2024

Dr.-Ing. Manuel Baumeister,
Head of Systems Engineering,
Technology & Innovation



SCHUNK SE & Co. KG
Spanntechnik | Greiftechnik | Automatisierungstechnik

Bahnhofstr. 106 - 134
D-74348 Lauffen/Neckar
Tel. +49-7133-103-0
info@de.schunk.com
schunk.com

Folgen Sie uns | *Follow us*



Wir drucken nachhaltig | *We print sustainable*