

Superior Clamping and Gripping



Product data sheet

Long-stroke gripper PSH

Compact. Flexible. Fully encapsulated.

Long-stroke gripper PSH

2-finger parallel gripper with long jaw stroke and dirt-resistant round guidance

Field of application

in contaminated work environments and for a large parts spectrum

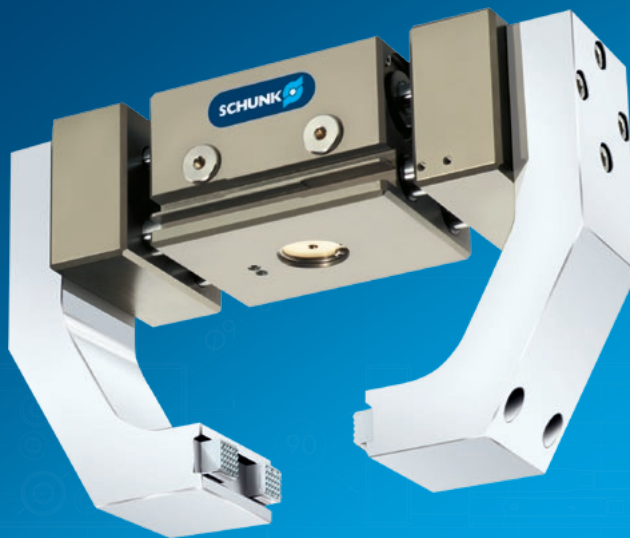

Advantages – Your benefits

High maximum moments possible suitable for using long gripper fingers

Dirt-protected round guidances sealed, for long strokes

Fastening at two gripper sides with centering for universal and flexible gripper assembly

Air supply via hose-free direct connection or screw connections for flexible pressure supply in all automated systems

Comprehensive sensor accessory program for versatile querying possibilities and stroke position monitoring



Sizes
Quantity: 4



Weight
0.77 .. 8.05 kg



Gripping force
320 .. 1760 N



Stroke per jaw
14 .. 100 mm



Workpiece weight
1.6 .. 8.8 kg

Functional description

By actuating the pistons with compressed air, the base jaws, which are located at the piston and the rack, are moved.

The jaw stroke is synchronized by means of rack and

pinion kinematics.

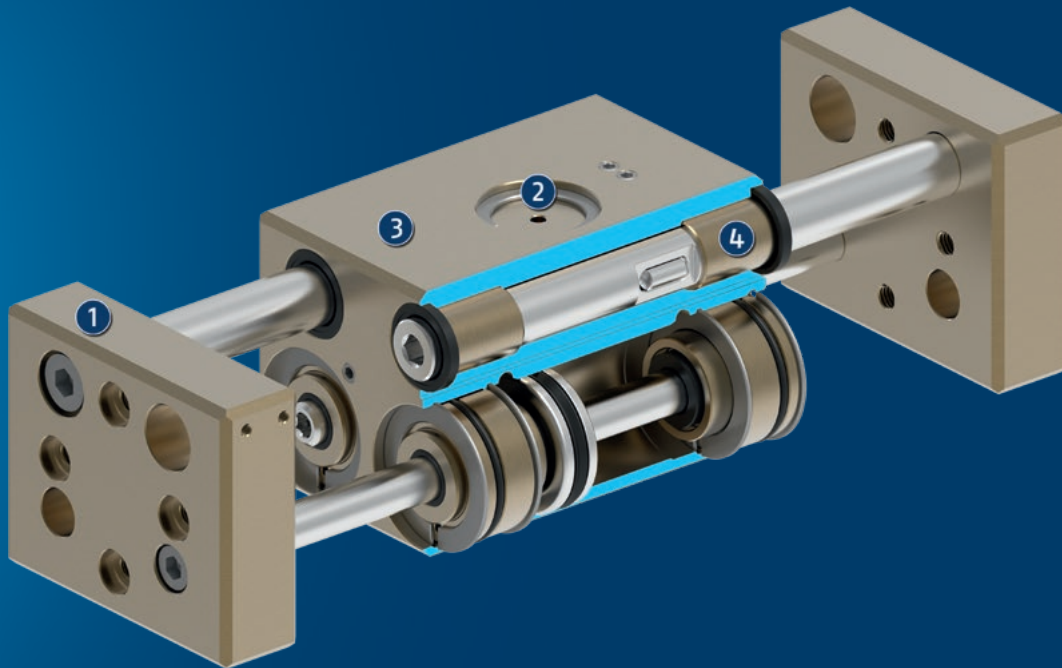

① **Base jaw**
for the connection of workpiece-specific gripper fingers

② **Kinematics**
Rack and pinion principle for centric gripping

③ **Housing**
is weight-optimized due to the use of high-strength aluminum alloy

④ **Round guidances**
sealed, for long strokes

General notes about the series

Operating principle: Rack and pinion principle

Housing material: hard-anodized, high strength aluminum

Base jaw material: hard-anodized, high strength aluminum

Actuation: pneumatic, with filtered compressed air as per ISO 8573-1:2010 [7:4:4].

Warranty: 24 months

Service life characteristics: on request

Scope of delivery: Centering sleeves, O-rings for direct connection, assembly instructions (operating manual with declaration of incorporation is available online)

Gripping force maintenance: possible with pressure maintenance valve SDV-P

Gripping force: is the arithmetic sum of the individual force applied to each jaw at distance P (see illustration).

Finger length: is measured from the reference surface as the distance P in direction to the main axis.

The maximum permissible finger length applies until the nominal operating pressure is achieved. With higher pressures, the finger length must be reduced proportionally to the nominal operating pressure.

Repeat accuracy: is defined as a distribution of the end Position for 100 consecutive strokes.

Workpiece weight: is calculated for force-fit gripping with a coefficient of static friction of 0.1 and a safety factor of 2 against workpiece slippage at acceleration due to gravity g. For form-fit or capture gripping, there are significantly higher permissible workpiece weights.

Closing and opening times: are movement times of the base jaws only, without application-specific gripper fingers. Valve switching times, hose fill times, or PLC reaction times are not included, and are to be considered when cycle times are calculated.

Application example

Rapid loading and unloading unit on a swivel head base. Due to the robustness of this unit, it is particularly suitable for use in machine tools.

- ① 2-finger parallel gripper PSH
- ② Swivel head SRH-plus

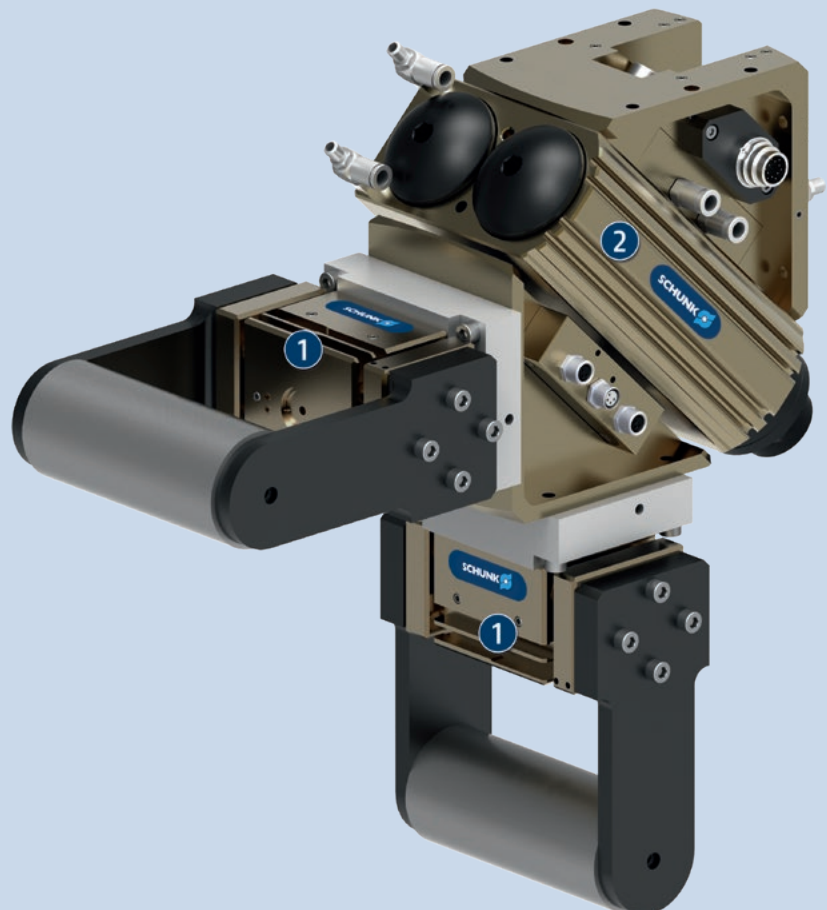

SCHUNK offers more ...

The following components make the product even more productive – the suitable addition for the highest functionality, flexibility, reliability, and controlled production.

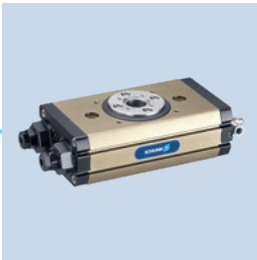

Universal swivel unit



Quick change system



Tolerance compensation unit



Pressure maintenance valve



Magnetic switches



Finger blank

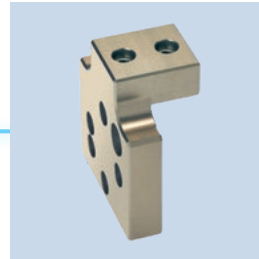

Intermediate jaw



Jaw quick-change system



Inductive proximity switch

① For more information on these products can be found on the following product pages or at [schunk.com](https://www.schunk.com).

Options and special information

Finger position: can be monitored by magnetic and/or inductive proximity switches. Unsynchronized version possible upon request as application-specific design.

High-temperature version VHT: for use in hot environments

ATEX version EX: for explosive environments

Additional versions: Various options can be combined with each other. Numerous additional options are also available – just tell us what your task is!

Food-grade lubrication: The product contains food-compliant lubricants as standard. The requirements of EN 1672-2:2020 are not fully met. The relevant NSF certificates are available at <https://info.nsf.org/USDA/Listings.asp> using the lubricant information in the operating manual.



Gripping force

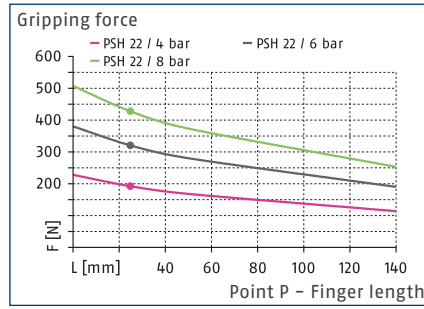

Dimensions and maximum loads

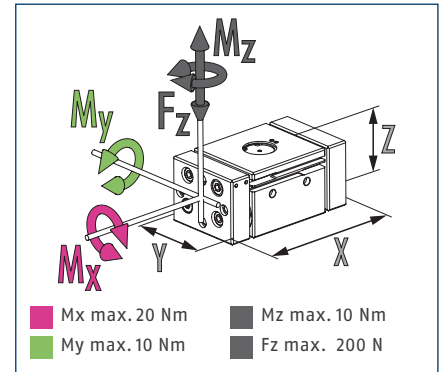

① The indicated moments and forces are static values, apply for each base jaw and may appear simultaneously. Loads may additionally occur to the moment produced by the gripping force itself.

Technical data

Description		PSH 22-1	PSH 22-2
ID		0302122	0302123
Stroke per jaw	[mm]	28	14
Closing/opening force	[N]	320/320	320/320
Weight	[kg]	0.95	0.77
Recommended workpiece weight	[kg]	1.6	1.6
Cylinder volume per double stroke	[cm³]	36	18
Min./nom./max. operating pressure	[bar]	3/6/8	3/6/8
Closing/opening time	[s]	0.15/0.15	0.12/0.12
Max. permissible finger length	[mm]	140	140
Max. permissible weight per finger	[kg]	0.8	0.8
IP protection class		67	67
Min./max. ambient temperature	[°C]	5/90	5/90
Repeat accuracy	[mm]	0.1	0.1
Dimensions X x Y x Z	[mm]	137 x 58 x 48	95 x 58 x 48
Options and their characteristics			
High-temperature version		39302122	39302123
Min./max. ambient temperature	[°C]	5/130	5/130

① It may take a few 100 gripping cycles until the full gripping force (as indicated in the data table) will be available.

Main view PSH 22-1

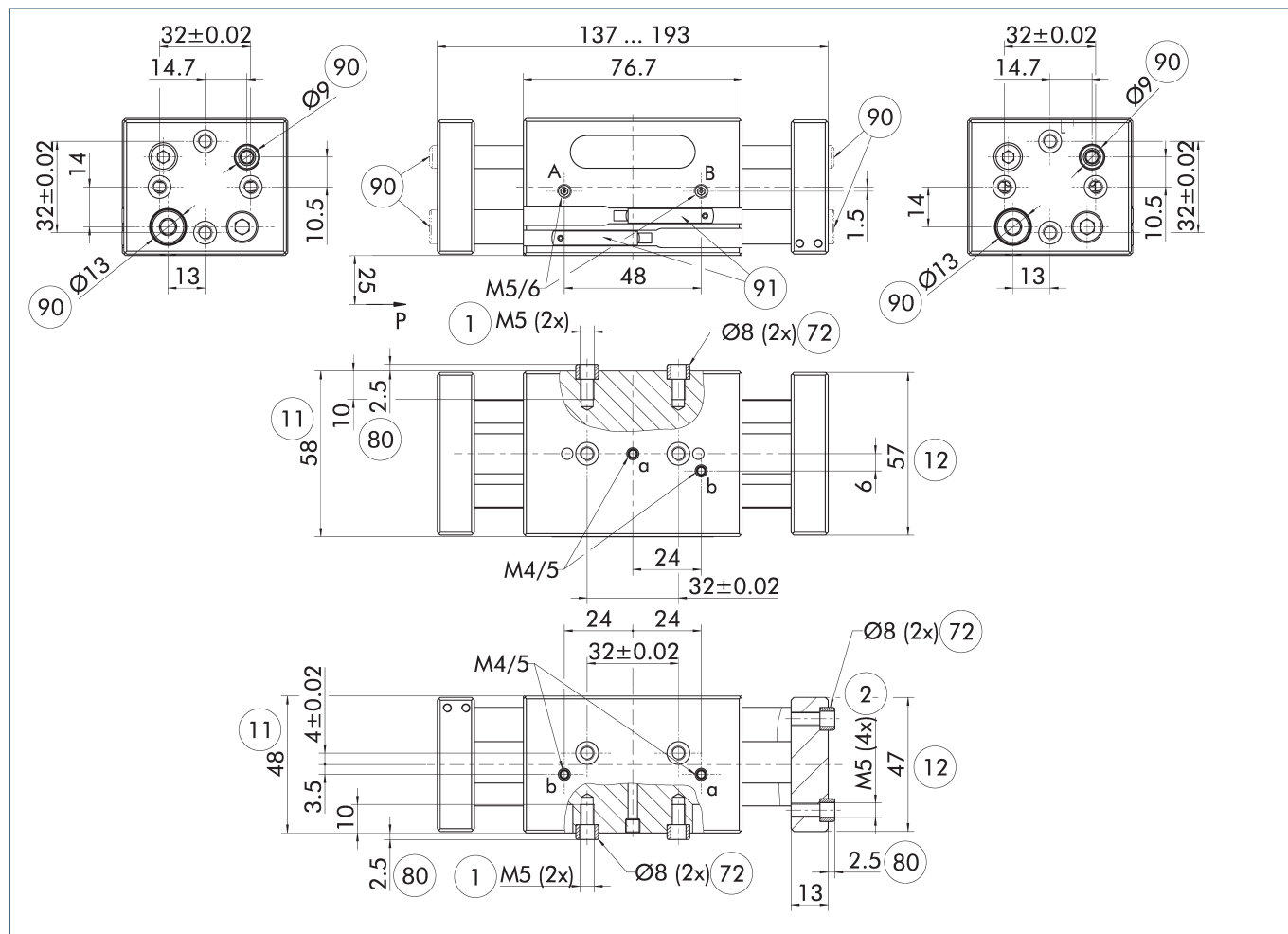

The drawing shows the gripper in the basic version with closed jaws, without dimensional consideration of the options described below.

① The SDV-P pressure maintenance valve can be used as a gripping force maintenance device (see catalog section on accessories).

A, a Main / direct connection, gripper opening

B, b Main / direct connection, gripper closing

① Gripper connection

② Finger connection

⑪ Housing

⑫ Jaw

⑦② Fit for centering sleeves

⑧① Depth of the centering sleeve hole in the counter part

⑨① Cut-out for the finger design

⑨① MMS 30... sensor

PSH 22

Long-stroke gripper

Maximum permitted finger projection

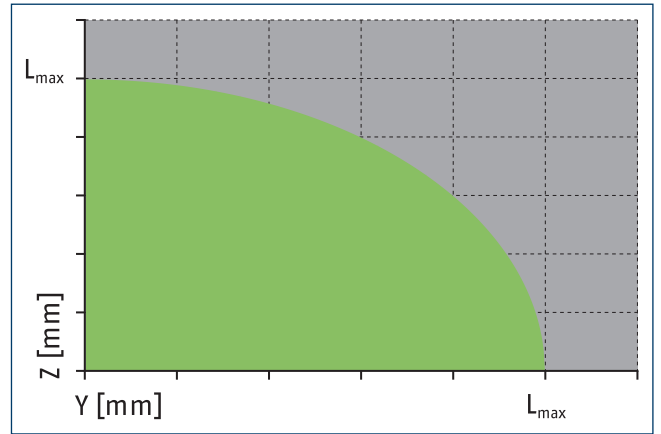
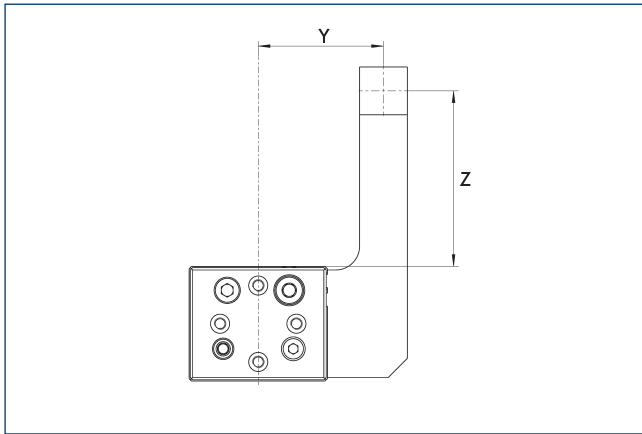

■ Permitted range ■ Inadmissible range

L_{max} is equivalent to the maximum permitted finger length, see the technical data table.

Hose-free direct connection M4 stroke variant PSH 22-1

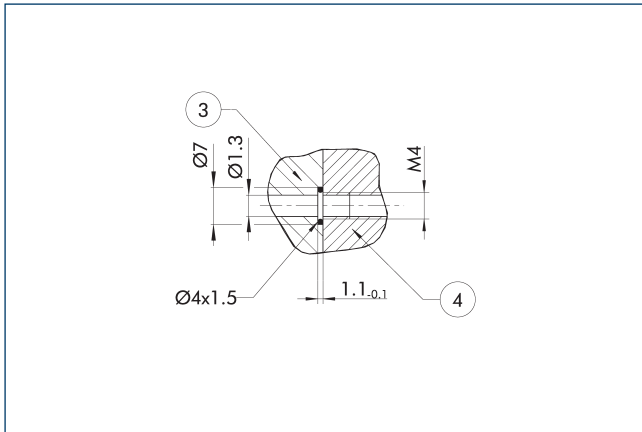

③ Adapter

④ Grippers

The direct connection is used for supplying compressed air without hoses. Instead, the pressure medium is fed through bore-holes in the mounting plate.

Hose-free direct connection M4 stroke variant PSH 22-2

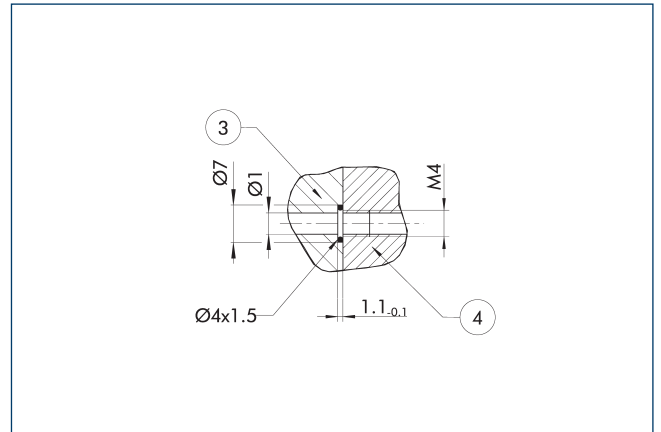

③ Adapter

④ Grippers

The direct connection is used for supplying compressed air without hoses. Instead, the pressure medium is fed through bore-holes in the mounting plate.

Stroke variant PSH 22-2

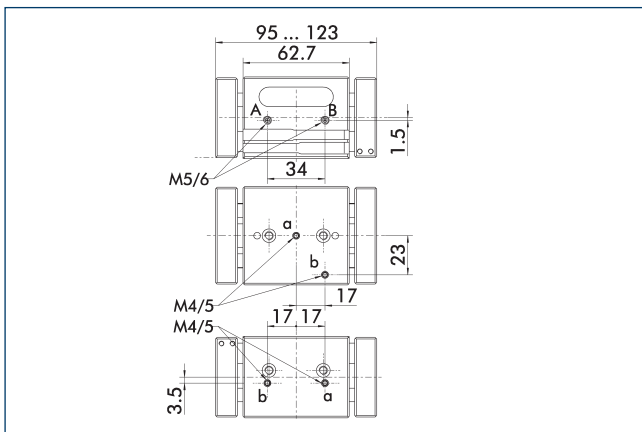

The drawing shows changes in dimensions of the version with a different stroke compared to the version shown in the main view.

Finger design

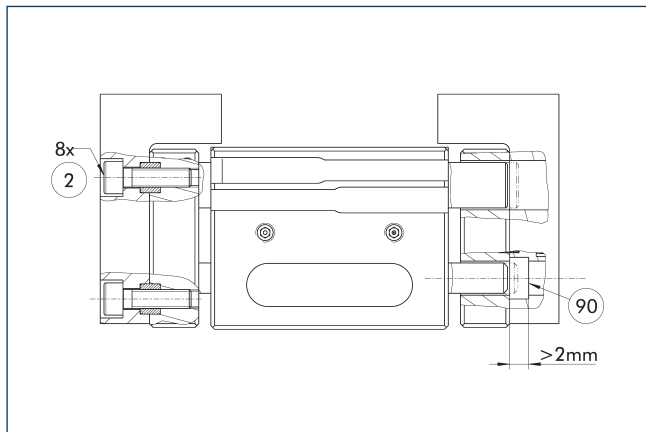

2 Finger connection 90 Recess

When closing the gripper completely, the piston rod can project beyond the end. If the entire closing stroke is required in the application, the recess is essential.

SDV-P pressure maintenance valve

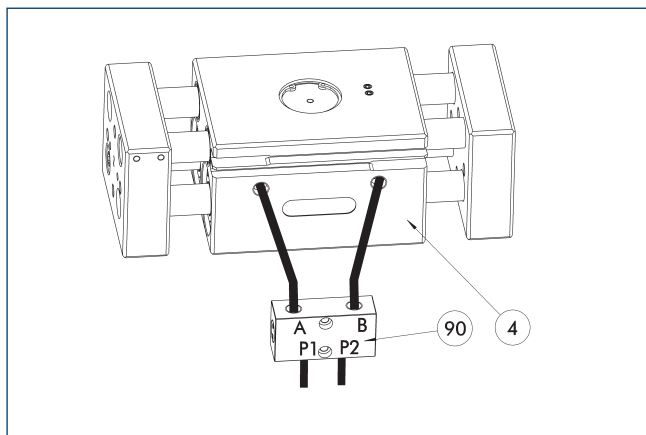

4 Grippers 90 SDV-P pressure maintenance valve

The SDV-P pressure maintenance valve ensures in emergency STOP situations that the pressure in the piston chamber of pneumatic gripper, swivel, linear, and quick-change modules is temporarily maintained.

Description	ID	Recommended hose diameter [mm]
Pressure maintenance valve		
SDV-P 04	0403130	6
Pressure maintenance valve with air bleed screw		
SDV-P 04-E	0300120	6

① In order to achieve the specified closing and opening time for each gripper variant, the recommended hose diameter must be used. The direct allocation of the respective variant of the gripper for the respective SDV-P can be found at schunk.com.

Intermediate jaw interface

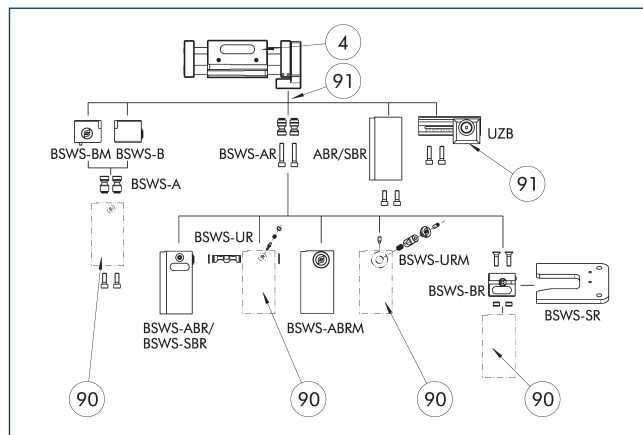

4 Grippers 91 Customized gripper fingers
90 Uniform screw connection pattern

By using the intermediate jaw, you have the possibility of directly connecting a wide range of accessories directly. This includes jaw quick-change systems, finger blanks, and universal intermediate jaws.

PSH 22

Long-stroke gripper

ZBA PSH 22-80 intermediate jaw

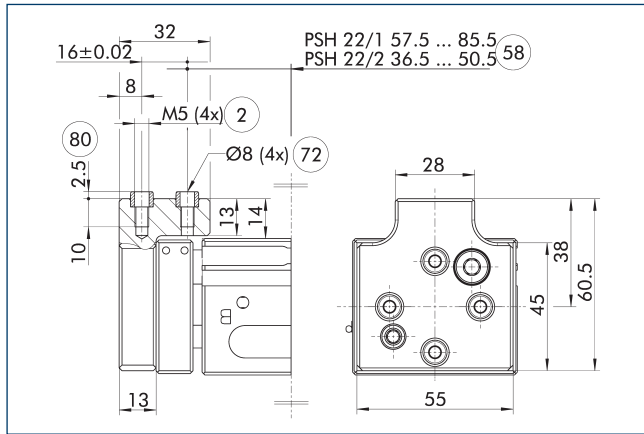

- ② Finger connection
- ⑤⑧ Distance from center of gripper
- ⑦② Fit for centering sleeves
- ⑧⑩ Depth of the centering sleeve hole in the counter part

Optionally intermediate jaws can be used, enabling direct connection and alignment of top jaws and various standard accessories in Z-direction.

Description	ID	Material	Finger interface	Scope of delivery
Intermediate jaw				
ZBA-PSH-22-80	0300225	Aluminum	PGN-plus 80	2

Inductive proximity switches

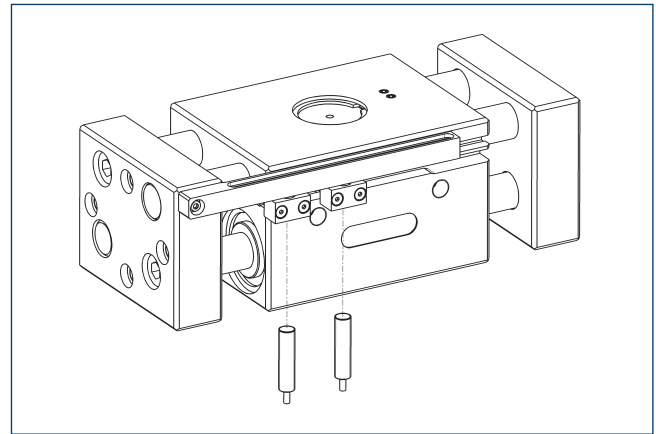

End position monitoring can be mounted with an attachment kit.

Description	ID	Often combined
Attachment kit for proximity switch		
HG-PSH 22-1	0300754	
HG-PSH 22-2	0300755	
Inductive proximity switch		
IN 80-S-M12	0301578	
IN 80-S-M8	0301478	●
IN-C 80-S-M8-PNP	0301475	
INK 80-S	0301550	
INK 80-SL	0301579	

- ① Two sensors (closer/S) are required for each unit and extension cables are available as an option. This attachment kit needs to be ordered optionally as an accessory. For sensor cables, note the minimum permissible bending radii. These are generally 35 mm.

Attachment kit for FPS

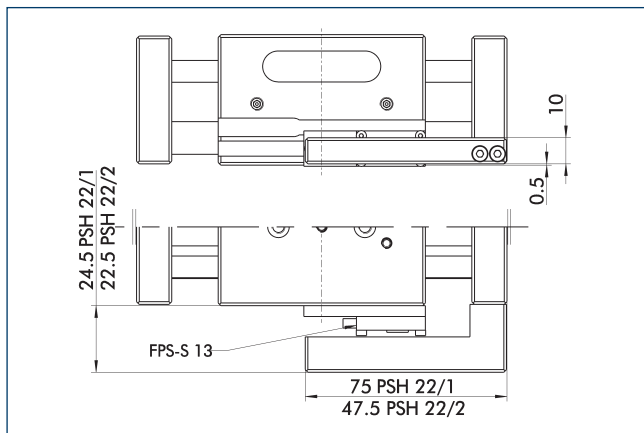

The following FPS position sensor can differentiate between five programmable areas or switching points for the stroke of a gripper, and can be used in connection with a PC as a measuring system.

Description	ID
Attachment kit for FPS	
AS-FPS-PSH 22-1	0301736
AS-FPS-PSH 22-2	0301737

- ① This attachment kit needs to be ordered optionally as an accessory.

Flexible position sensor

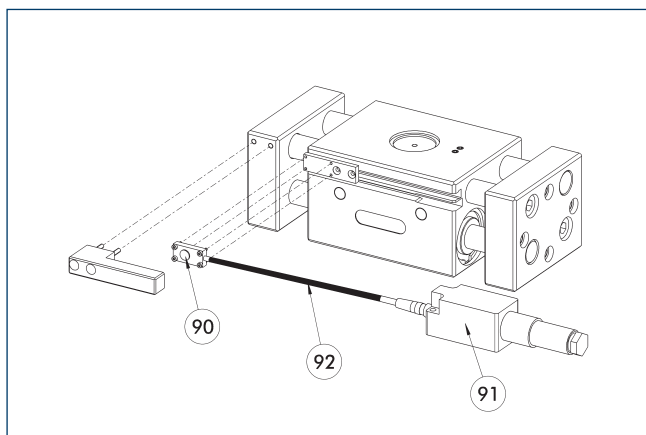

- 90 FPS-S sensor 92 Cable extension
 91 FPS-F5 evaluation electronic

Flexible position monitoring of up to five positions.

Description	ID	Often combined
Attachment kit for FPS		
AS-FPS-PSH 22-1	0301736	
AS-FPS-PSH 22-2	0301737	
Sensor		
FPS-S 13	0301705	
Evaluation electronics		
FPS-F5	0301805	●
Cable extension		
KV BG08-SG08 3P-0050	0301598	
KV BG08-SG08 3P-0100	0301599	

- ⓘ When using an FPS system, an FPS sensor (FPS-S) as well as an electronic processor (FPS-F5 / F5 T) are required for each gripper as well as a mounting kit (AS), if listed. Cable extensions (KV) are optionally available – see catalog chapter "Accessories."

Electronic magnetic switch MMS

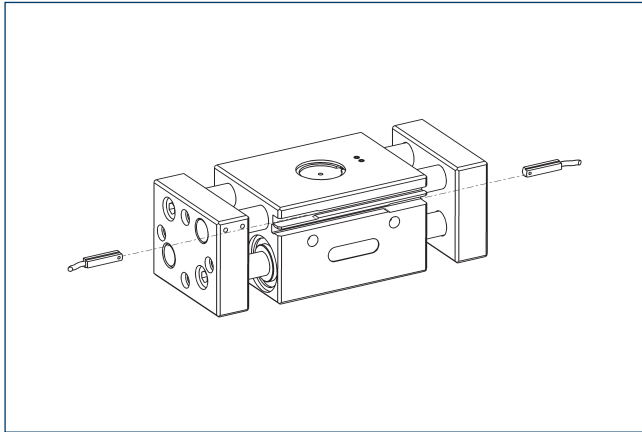

End position monitoring for mounting in the T-slot

Description	ID	Often combined
Electronic magnetic switch		
MMS 30-S-M12-PNP	0301571	
MMS 30-S-M8-PNP	0301471	●
MMSK 30-S-PNP	0301563	
Connection cables		
KA BG08-L 3P-0300-PNP	0301622	●
KA BG08-L 3P-0500-PNP	0301623	
KA BG12-L 3P-0500-PNP	30016369	
KA BW08-L 3P-0300-PNP	0301594	
KA BW08-L 3P-0500-PNP	0301502	
Clip for connector/socket		
CLI-M12	0301464	
CLI-M8	0301463	
Cable extension		
KV BG12-SG12 3P-0030-PNP	0301999	
KV BG12-SG12 3P-0060-PNP	0301998	
KV BW08-SG08 3P-0030-PNP	0301495	
KV BW08-SG08 3P-0100-PNP	0301496	
KV BW08-SG08 3P-0200-PNP	0301497	●
KV BW12-SG12 3P-0030-PNP	0301595	
KV BW12-SG12 3P-0100-PNP	0301596	
KV BW12-SG12 3P-0200-PNP	0301597	
Sensor distributor		
V2-M8	0301775	●
V4-M8	0301746	
V8-M8	0301751	

- ① Two sensors are required per unit for monitoring two positions. On option, extension cables and sensor distributors are available. Additional product variants of the sensor, and further information and technical data can be found in the catalog chapter sensor system.



Gripping force

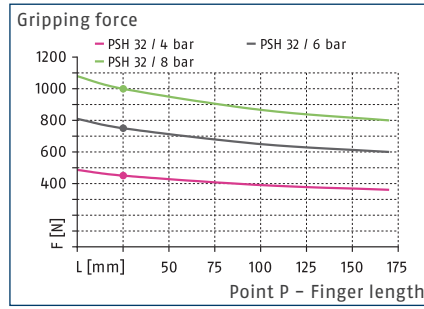

Dimensions and maximum loads

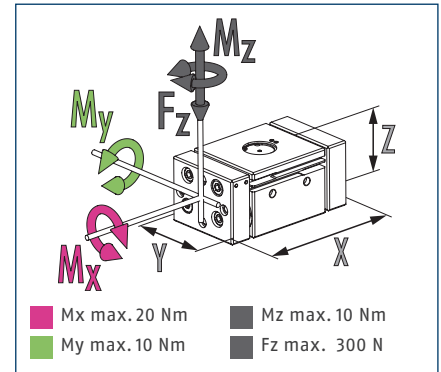

① The indicated moments and forces are static values, apply for each base jaw and may appear simultaneously. Loads may additionally occur to the moment produced by the gripping force itself.

Technical data

Description		PSH 32-1	PSH 32-2
ID		0302132	0302133
Stroke per jaw	[mm]	35	22.5
Closing/opening force	[N]	750/750	750/750
Weight	[kg]	2.05	1.8
Recommended workpiece weight	[kg]	3.75	3.75
Cylinder volume per double stroke	[cm ³]	101	65
Min./nom./max. operating pressure	[bar]	3/6/8	3/6/8
Closing/opening time	[s]	0.2/0.2	0.12/0.12
Max. permissible finger length	[mm]	170	170
Max. permissible weight per finger	[kg]	1.5	1.5
IP protection class		67	67
Min./max. ambient temperature	[°C]	5/90	5/90
Repeat accuracy	[mm]	0.1	0.1
Dimensions X x Y x Z	[mm]	171 x 76 x 63	133 x 76 x 63
Options and their characteristics			
High-temperature version		39302132	39302133
Min./max. ambient temperature	[°C]	5/130	5/130

① It may take a few 100 gripping cycles until the full gripping force (as indicated in the data table) will be available.

Main view PSH 32-1

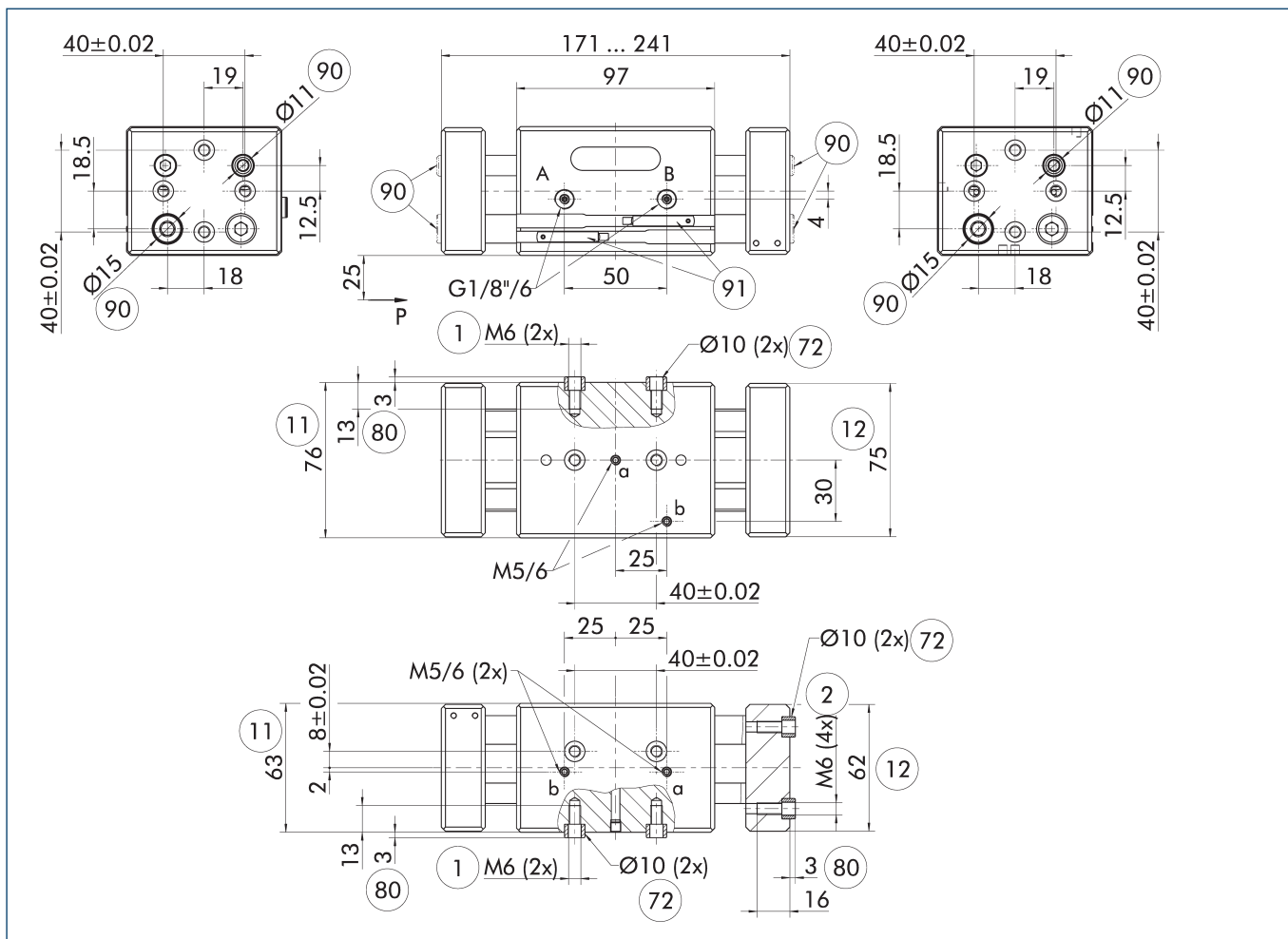

The drawing shows the gripper in the basic version with closed jaws, without dimensional consideration of the options described below.

① The SDV-P pressure maintenance valve can be used as a gripping force maintenance device (see catalog section on accessories).

- A, a Main / direct connection, gripper opening
- B, b Main / direct connection, gripper closing
- ① Gripper connection
- ② Finger connection
- ⑪ Housing

- ⑫ Jaw
- ⑦② Fit for centering sleeves
- ⑧① Depth of the centering sleeve hole in the counter part
- ⑨① Cut-out for the finger design
- ⑨① MMS 30... sensor

PSH 32

Long-stroke gripper

Maximum permitted finger projection

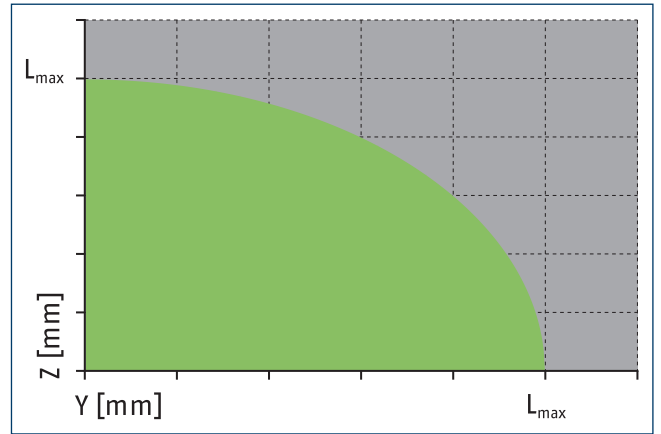
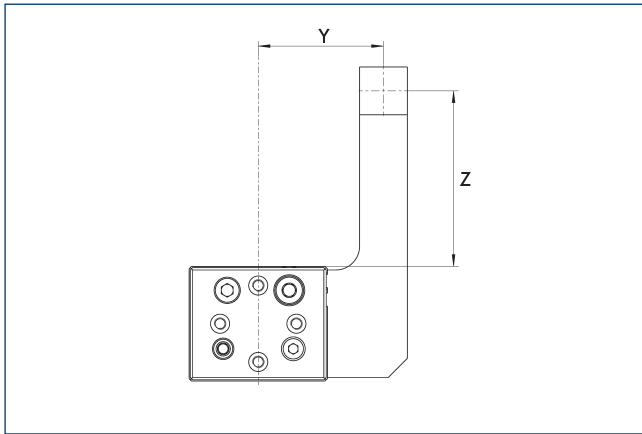

■ Permitted range ■ Inadmissible range

L_{max} is equivalent to the maximum permitted finger length, see the technical data table.

Hose-free direct connection M5 stroke variant PSH 32-1

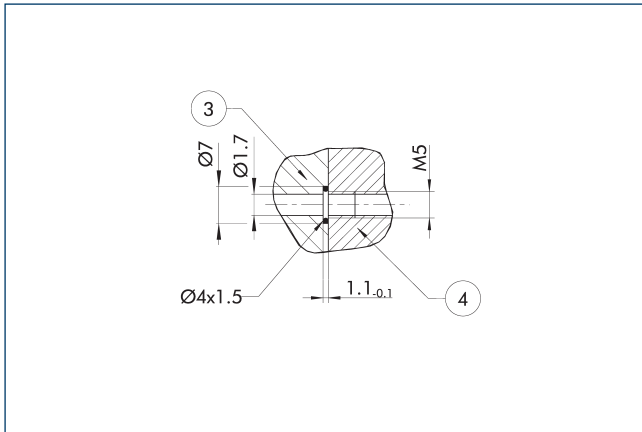

③ Adapter

④ Grippers

The direct connection is used for supplying compressed air without hoses. Instead, the pressure medium is fed through bore-holes in the mounting plate.

Hose-free direct connection M5 stroke variant PSH 32-2

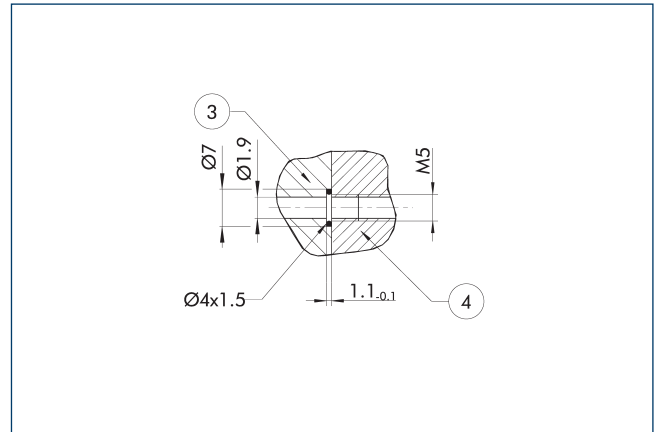

③ Adapter

④ Grippers

The direct connection is used for supplying compressed air without hoses. Instead, the pressure medium is fed through bore-holes in the mounting plate.

Stroke variant PSH 32-2

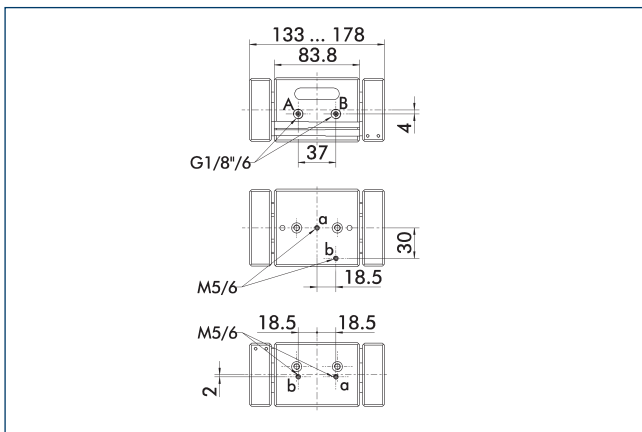

The drawing shows changes in dimensions of the version with a different stroke compared to the version shown in the main view.

Finger design

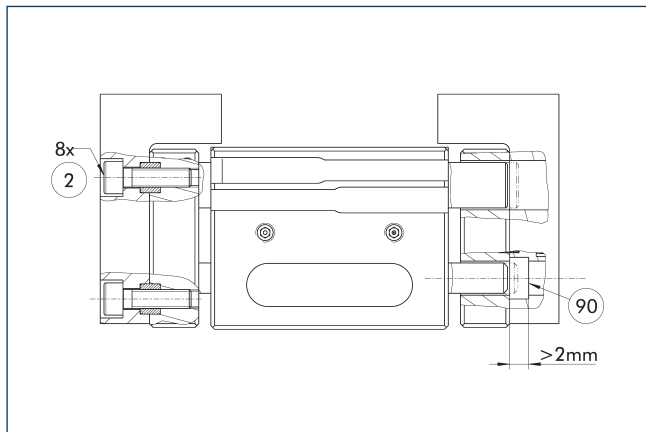

2 Finger connection 90 Recess

When closing the gripper completely, the piston rod can project beyond the end. If the entire closing stroke is required in the application, the recess is essential.

SDV-P pressure maintenance valve

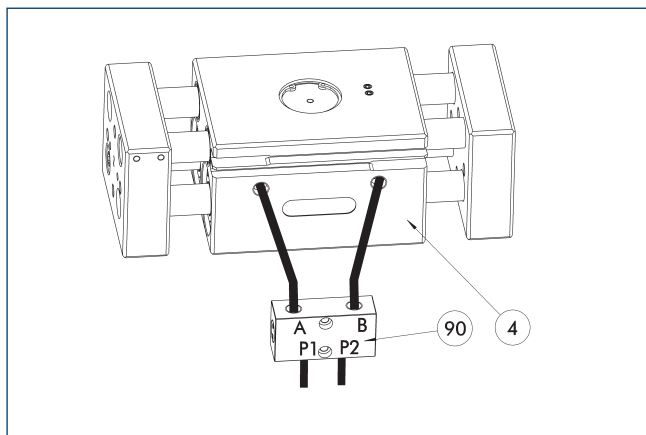

4 Grippers 90 SDV-P pressure maintenance valve

The SDV-P pressure maintenance valve ensures in emergency STOP situations that the pressure in the piston chamber of pneumatic gripper, swivel, linear, and quick-change modules is temporarily maintained.

Description	ID	Recommended hose diameter [mm]
Pressure maintenance valve		
SDV-P 04	0403130	6
Pressure maintenance valve with air bleed screw		
SDV-P 04-E	0300120	6

① In order to achieve the specified closing and opening time for each gripper variant, the recommended hose diameter must be used. The direct allocation of the respective variant of the gripper for the respective SDV-P can be found at schunk.com.

Intermediate jaw interface

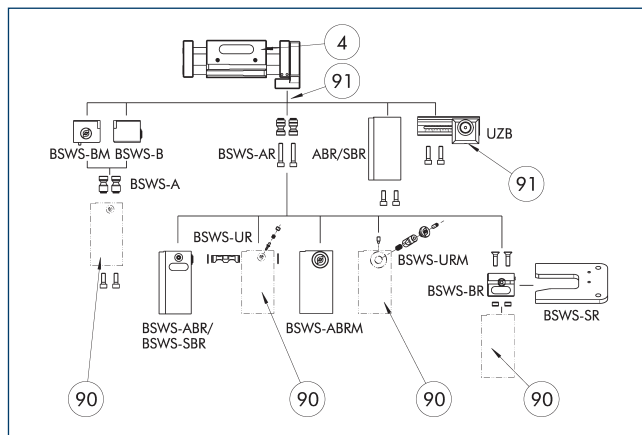

4 Grippers 90 Uniform screw connection pattern 91 Customized gripper fingers

By using the intermediate jaw, you have the possibility of directly connecting a wide range of accessories directly. This includes jaw quick-change systems, finger blanks, and universal intermediate jaws.

PSH 32

Long-stroke gripper

ZBA PSH 32-100 intermediate jaw

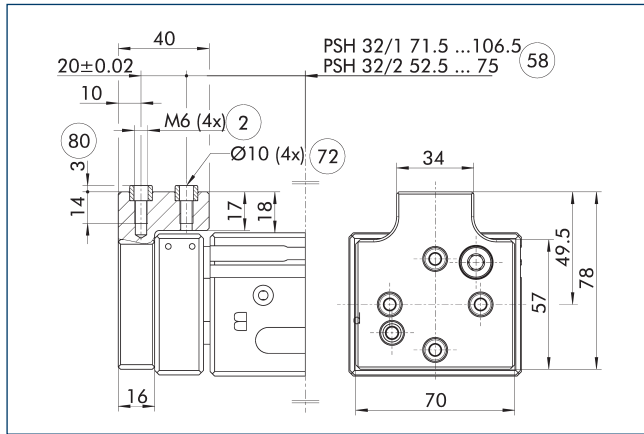

- ② Finger connection
- ⑤⑧ Distance from center of gripper
- ⑦② Fit for centering sleeves
- ⑧⑩ Depth of the centering sleeve hole in the counter part

Optionally intermediate jaws can be used, enabling direct connection and alignment of top jaws and various standard accessories in Z-direction.

Description	ID	Material	Finger interface	Scope of delivery
Intermediate jaw				
ZBA-PSH-32-100	0300226	Aluminum	PGN-plus 100	2

Inductive proximity switches

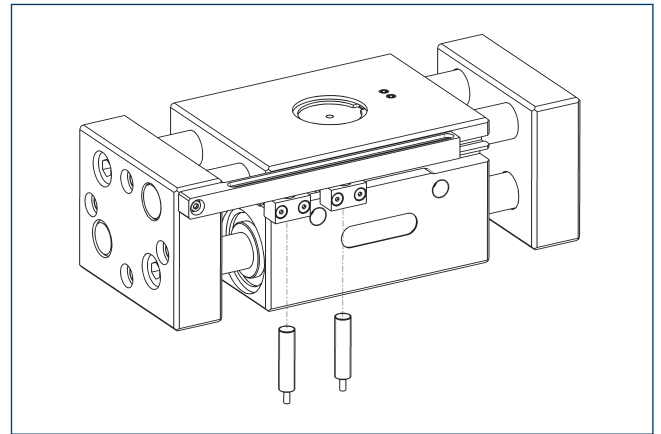

End position monitoring can be mounted with an attachment kit.

Description	ID	Often combined
Attachment kit for proximity switch		
HG-PSH 32	0300756	
Inductive proximity switch		
IN 80-S-M12	0301578	
IN 80-S-M8	0301478	●
IN-C 80-S-M8-PNP	0301475	
INK 80-S	0301550	
INK 80-SL	0301579	

- ① Two sensors (closer/S) are required for each unit and extension cables are available as an option. This attachment kit needs to be ordered optionally as an accessory. For sensor cables, note the minimum permissible bending radii. These are generally 35 mm.

Attachment kit for FPS

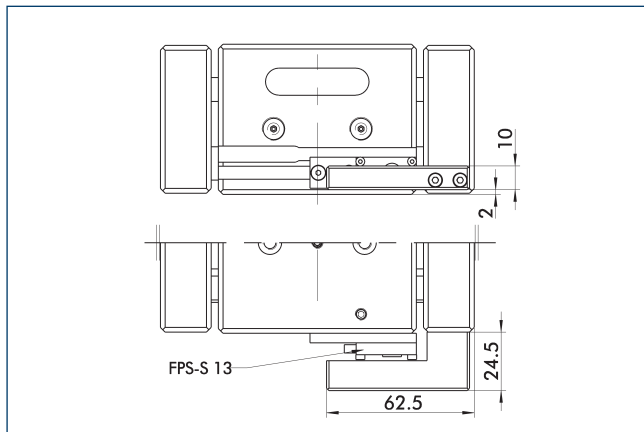

The following FPS position sensor can differentiate between five programmable areas or switching points for the stroke of a gripper, and can be used in connection with a PC as a measuring system.

Description	ID
Attachment kit for FPS	
AS-FPS-PSH 32-2	0301738

- ① This attachment kit needs to be ordered optionally as an accessory.

Flexible position sensor

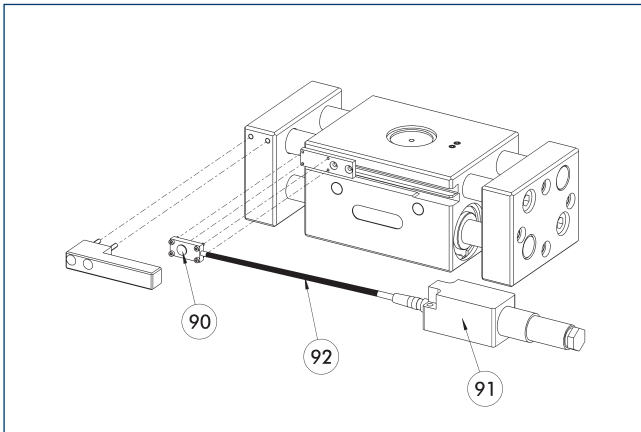

- 90 FPS-S sensor 92 Cable extension
 91 FPS-F5 evaluation electronic

Flexible position monitoring of up to five positions.

Description	ID	Often combined
Attachment kit for FPS		
AS-FPS-PSH 32-2	0301738	
Sensor		
FPS-S 13	0301705	
Evaluation electronics		
FPS-F5	0301805	●
Cable extension		
KV BG08-SG08 3P-0050	0301598	
KV BG08-SG08 3P-0100	0301599	

- ⓘ When using an FPS system, an FPS sensor (FPS-S) as well as an electronic processor (FPS-F5 / F5 T) are required for each gripper as well as a mounting kit (AS), if listed. Cable extensions (KV) are optionally available – see catalog chapter “Accessories.”

Electronic magnetic switch MMS

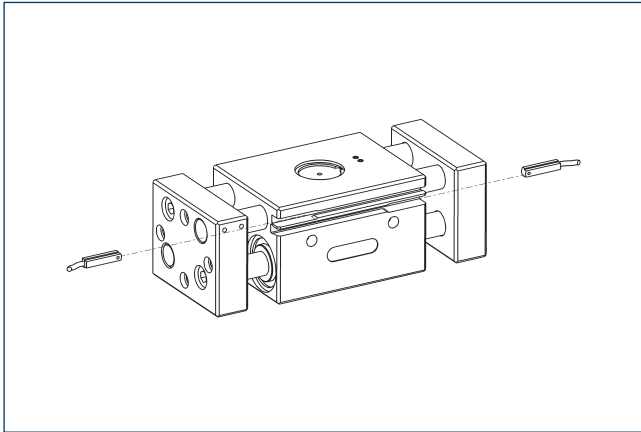

End position monitoring for mounting in the T-slot

Description	ID	Often combined
Electronic magnetic switch		
MMS 30-S-M12-PNP	0301571	
MMS 30-S-M8-PNP	0301471	●
MMSK 30-S-PNP	0301563	
Connection cables		
KA BG08-L 3P-0300-PNP	0301622	●
KA BG08-L 3P-0500-PNP	0301623	
KA BG12-L 3P-0500-PNP	30016369	
KA BW08-L 3P-0300-PNP	0301594	
KA BW08-L 3P-0500-PNP	0301502	
Clip for connector/socket		
CLI-M12	0301464	
CLI-M8	0301463	
Cable extension		
KV BG12-SG12 3P-0030-PNP	0301999	
KV BG12-SG12 3P-0060-PNP	0301998	
KV BW08-SG08 3P-0030-PNP	0301495	
KV BW08-SG08 3P-0100-PNP	0301496	
KV BW08-SG08 3P-0200-PNP	0301497	●
KV BW12-SG12 3P-0030-PNP	0301595	
KV BW12-SG12 3P-0100-PNP	0301596	
KV BW12-SG12 3P-0200-PNP	0301597	
Sensor distributor		
V2-M8	0301775	●
V4-M8	0301746	
V8-M8	0301751	

- ① Two sensors are required per unit for monitoring two positions. On option, extension cables and sensor distributors are available. Additional product variants of the sensor, and further information and technical data can be found in the catalog chapter sensor system.

PSH 42

Long-stroke gripper



Gripping force

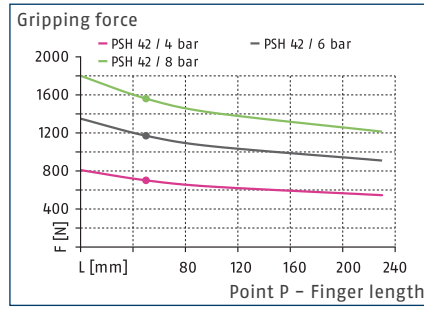

Dimensions and maximum loads

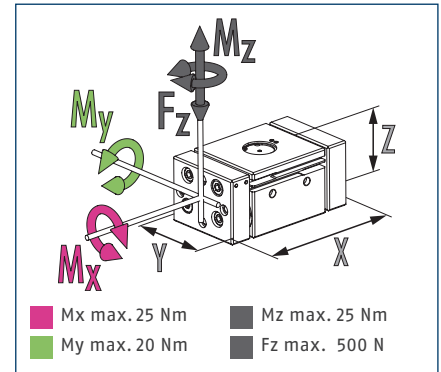

① The indicated moments and forces are static values, apply for each base jaw and may appear simultaneously. Loads may additionally occur to the moment produced by the gripping force itself.

Technical data

Description		PSH 42-100	PSH 42-1	PSH 42-2
ID		0302146	0302142	0302143
Stroke per jaw	[mm]	100	50	29
Closing/opening force	[N]	1170/1170	1170/1170	1170/1170
Weight	[kg]	6.7	4.65	3.9
Recommended workpiece weight	[kg]	6	6	6
Cylinder volume per double stroke	[cm ³]	510	255	148
Min./nom./max. operating pressure	[bar]	3/6/8	3/6/8	3/6/8
Closing/opening time	[s]	0.4/0.4	0.25/0.25	0.15/0.15
Max. permissible finger length	[mm]	230	230	230
Max. permissible weight per finger	[kg]	2.5	2.5	2.5
IP protection class		67	67	67
Min./max. ambient temperature	[°C]	5/90	5/90	5/90
Repeat accuracy	[mm]	0.05	0.05	0.05
Dimensions X x Y x Z	[mm]	326 x 97 x 77	232 x 97 x 77	168 x 97 x 77
Options and their characteristics				
High-temperature version		39302146	39302142	39302143
Min./max. ambient temperature	[°C]	5/130	5/130	5/130

① It may take a few 100 gripping cycles until the full gripping force (as indicated in the data table) will be available.

Main view PSH 42-1

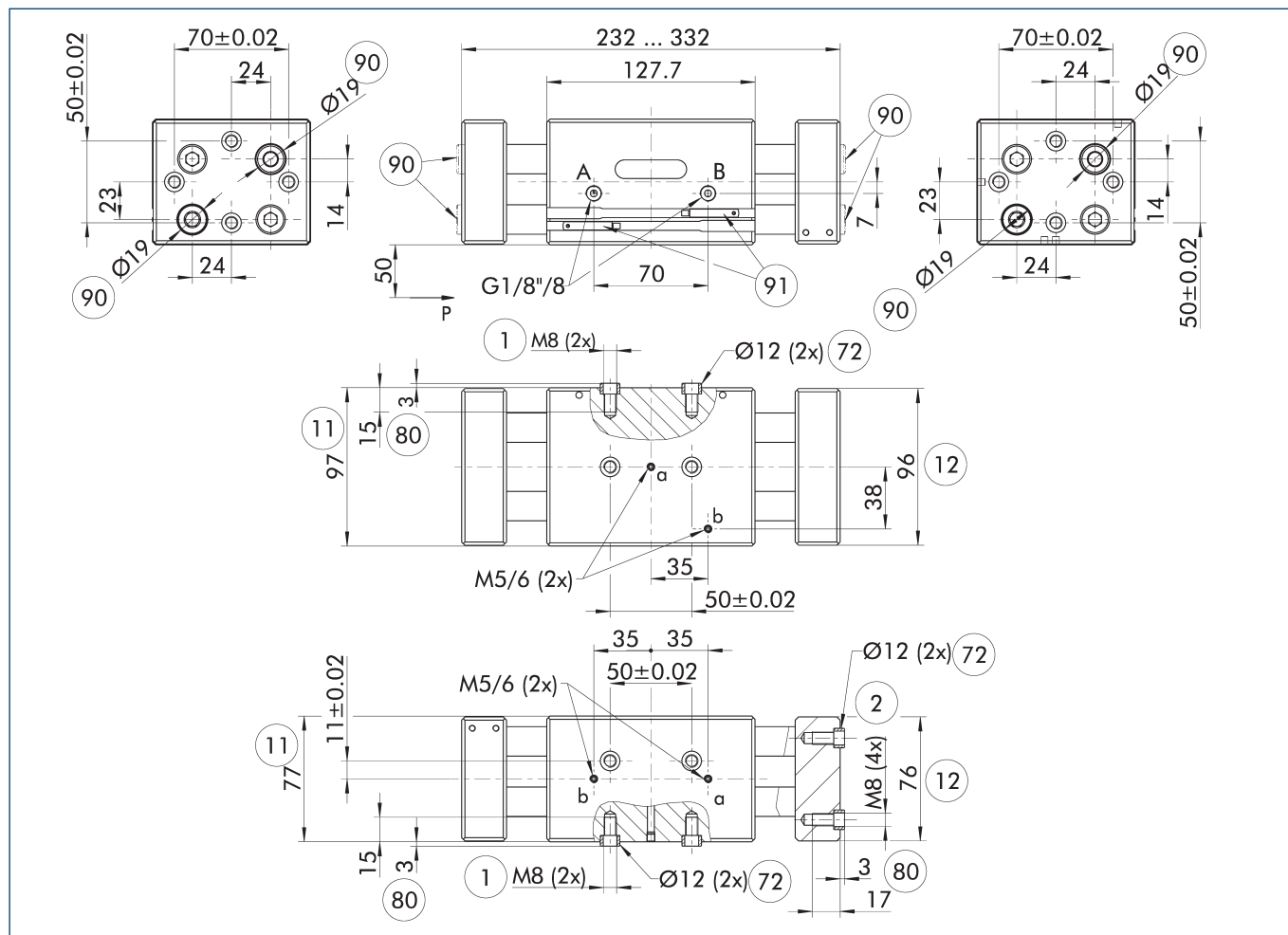

The drawing shows the gripper in the basic version with closed jaws, without dimensional consideration of the options described below.

① The SDV-P pressure maintenance valve can be used as a gripping force maintenance device (see catalog section on accessories).

- A, a Main / direct connection, gripper opening
- B, b Main / direct connection, gripper closing
- ① Gripper connection
- ② Finger connection
- ⑪ Housing
- ⑫ Jaw
- ⑭ Fit for centering sleeves
- ⑮ Depth of the centering sleeve hole in the counter part
- ⑯ Cut-out for the finger design
- ⑰ MMS 30... sensor

PSH 42

Long-stroke gripper

Attachment kit for proximity switch

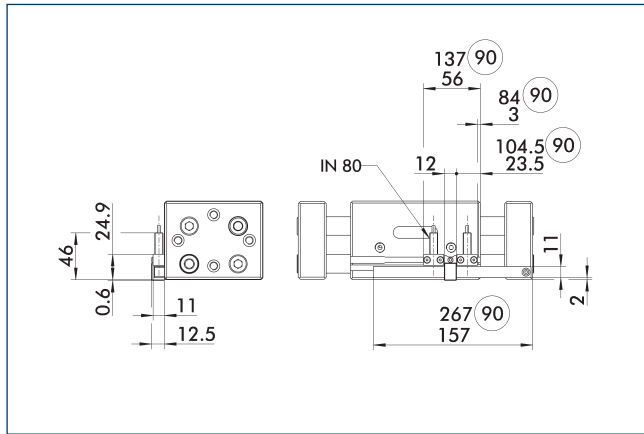

The drawing shows the gripper in the basic version with closed jaws, without dimensional consideration of the options described below.

- ① The SDV-P pressure maintenance valve can be used as a gripping force maintenance device (see catalog section on accessories).

Maximum permitted finger projection

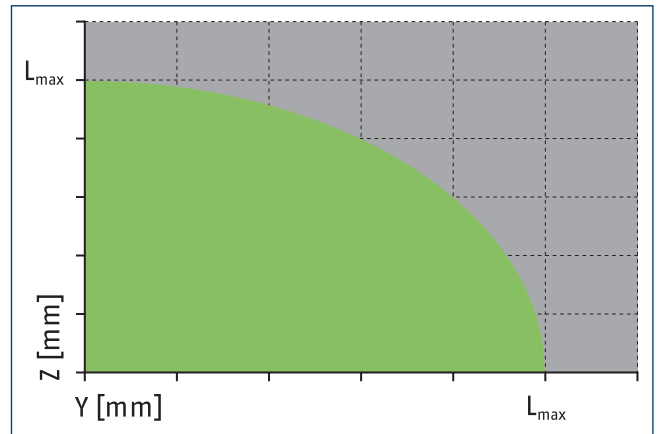
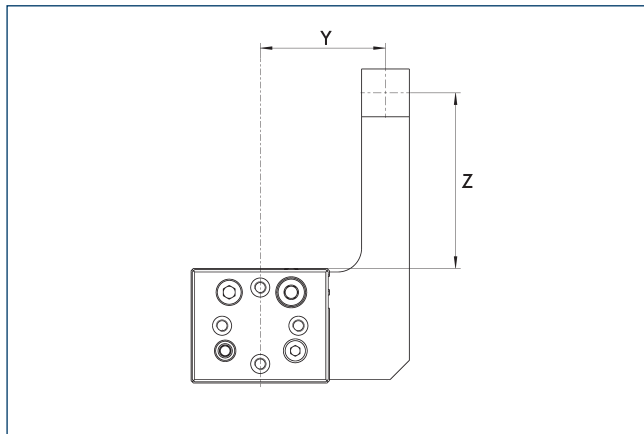

■ Permitted range ■ Inadmissible range

L_{max} is equivalent to the maximum permitted finger length, see the technical data table.

Hose-free direct connection M5

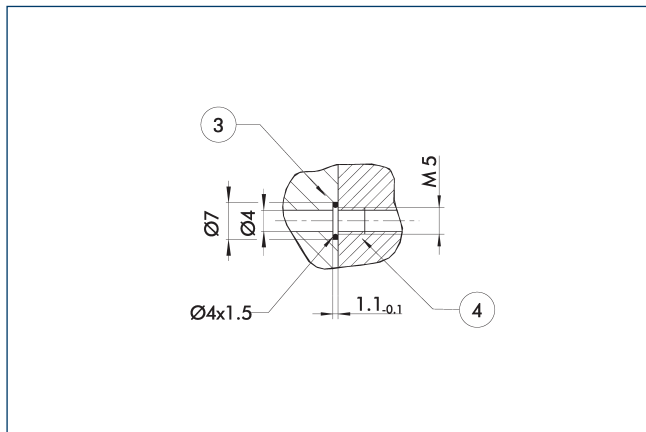

- ③ Adapter
- ④ Grippers

The direct connection is used for supplying compressed air without hoses. Instead, the pressure medium is fed through bore-holes in the mounting plate.

Stroke variant PSH 42-2

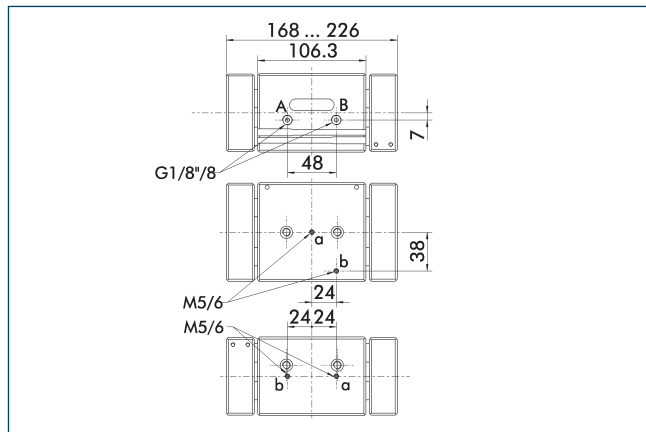

The drawing shows changes in dimensions of the version with a different stroke compared to the version shown in the main view.

PSH 42-100 stroke version

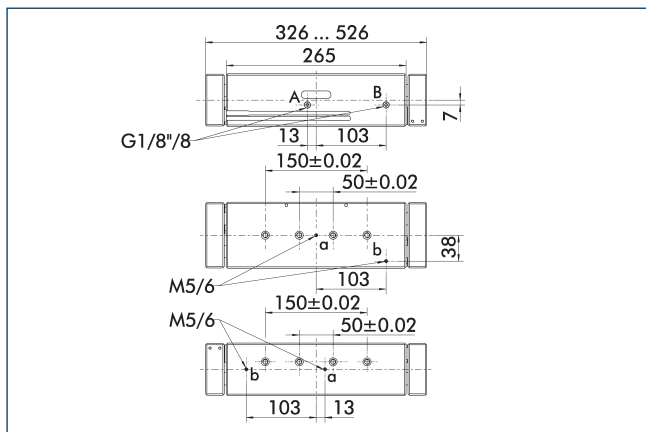

The drawing shows changes in dimensions of the version with a different stroke compared to the version shown in the main view.

Finger design

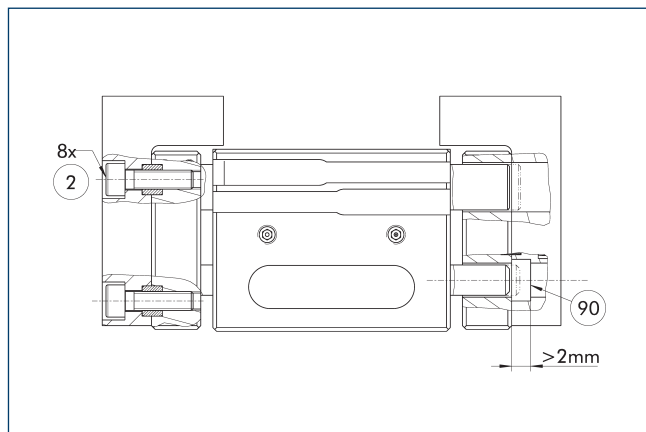

- ② Finger connection
- ⑨〇 Recess

When closing the gripper completely, the piston rod can project beyond the end. If the entire closing stroke is required in the application, the recess is essential.

PSH 42

Long-stroke gripper

SDV-P pressure maintenance valve

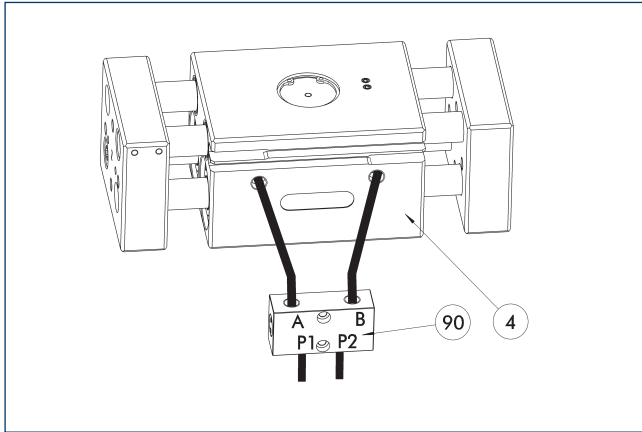

- ④ Grippers
- ⑨⑩ SDV-P pressure maintenance valve

The SDV-P pressure maintenance valve ensures in emergency STOP situations that the pressure in the piston chamber of pneumatic gripper, swivel, linear, and quick-change modules is temporarily maintained.

Description	ID	Recommended hose diameter [mm]
Pressure maintenance valve		
SDV-P 07	0403131	8
Pressure maintenance valve with air bleed screw		
SDV-P 07-E	0300121	8

① In order to achieve the specified closing and opening time for each gripper variant, the recommended hose diameter must be used. The direct allocation of the respective variant of the gripper for the respective SDV-P can be found at schunk.com.

Intermediate jaw interface

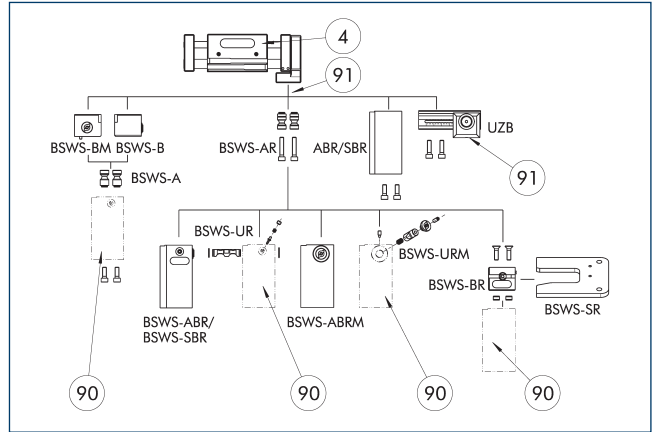

- ④ Grippers
- ⑨⑩ Uniform screw connection pattern
- ⑨① Customized gripper fingers

By using the intermediate jaw, you have the possibility of directly connecting a wide range of accessories directly. This includes jaw quick-change systems, finger blanks, and universal intermediate jaws.

ZBA PSH 42-125 intermediate jaw

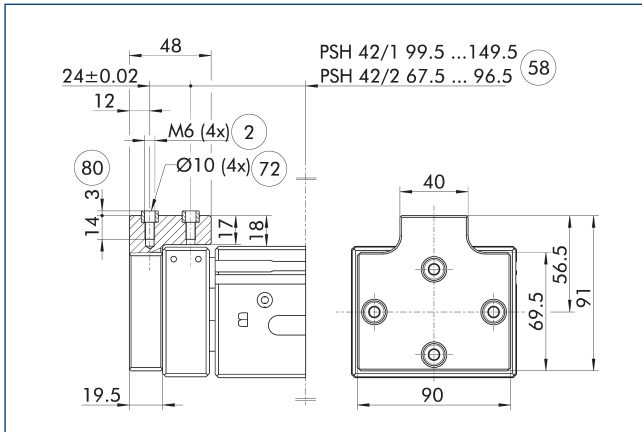

- ② Finger connection
- ⑤⑧ Distance from center of gripper
- ⑦② Fit for centering sleeves
- ⑧⑩ Depth of the centering sleeve hole in the counter part

Optionally intermediate jaws can be used, enabling direct connection and alignment of top jaws and various standard accessories in Z-direction.

Description	ID	Material	Finger interface	Scope of delivery
Intermediate jaw				
ZBA-PSH-42-125	0300227	Aluminum	PGN-plus 125	2

Inductive proximity switches

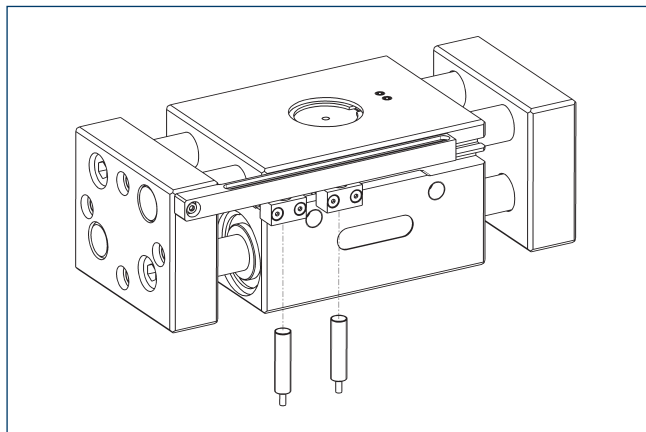

End position monitoring can be mounted with an attachment kit.

Description	ID	Often combined
Attachment kit for proximity switch		
HG-PSH 42	0300757	
HG-PSH 42-100	0301771	
Inductive proximity switch		
IN 80-S-M12	0301578	
IN 80-S-M8	0301478	●
INK 80-S	0301550	

① Two sensors (closer/S) are required for each unit and extension cables are available as an option. This attachment kit needs to be ordered optionally as an accessory. For sensor cables, note the minimum permissible bending radii. These are generally 35 mm.

Attachment kit for FPS

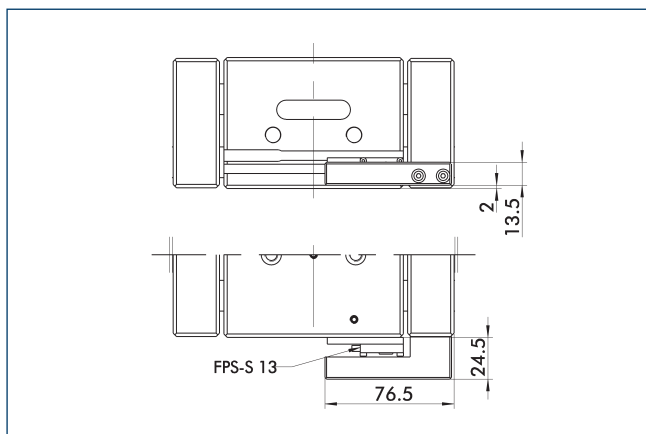

The following FPS position sensor can differentiate between five programmable areas or switching points for the stroke of a gripper, and can be used in connection with a PC as a measuring system.

Description	ID	
Attachment kit for FPS		
AS-FPS-PSH 42-2	0301739	

① This attachment kit needs to be ordered optionally as an accessory.

Flexible position sensor

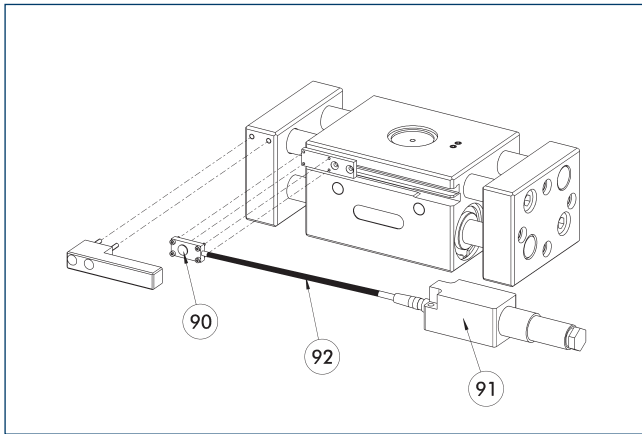

- ⑨⑩ FPS-S sensor
- ⑨① FPS-F5 evaluation electronic
- ⑨② Cable extension

Flexible position monitoring of up to five positions.

Description	ID	Often combined
Attachment kit for FPS		
AS-FPS-PSH 42-2	0301739	
Sensor		
FPS-S 13	0301705	
Evaluation electronics		
FPS-F5	0301805	●
Cable extension		
KV BG08-SG08 3P-0050	0301598	
KV BG08-SG08 3P-0100	0301599	

- ① When using an FPS system, an FPS sensor (FPS-S) as well as an electronic processor (FPS-F5 / F5 T) are required for each gripper as well as a mounting kit (AS), if listed. Cable extensions (KV) are optionally available – see catalog chapter “Accessories.”

Electronic magnetic switch MMS

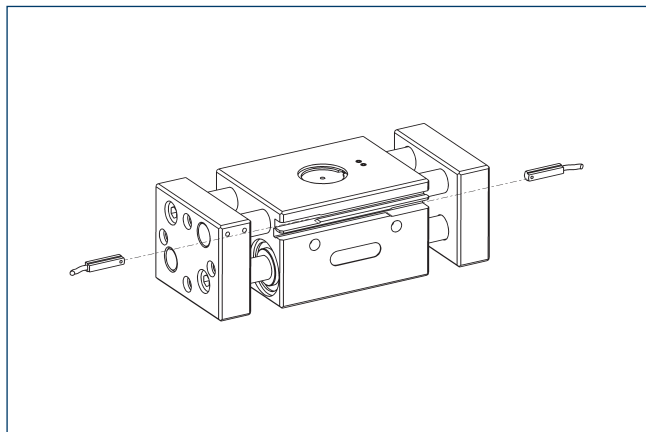

End position monitoring for mounting in the T-slot

Description	ID	Often combined
Electronic magnetic switch		
MMS 30-S-M12-PNP	0301571	
MMS 30-S-M8-PNP	0301471	●
MMSK 30-S-PNP	0301563	
Connection cables		
KA BG08-L 3P-0300-PNP	0301622	●
KA BG08-L 3P-0500-PNP	0301623	
KA BG12-L 3P-0500-PNP	30016369	
KA BW08-L 3P-0300-PNP	0301594	
KA BW08-L 3P-0500-PNP	0301502	
Clip for connector/socket		
CLI-M12	0301464	
CLI-M8	0301463	
Cable extension		
KV BG12-SG12 3P-0030-PNP	0301999	
KV BG12-SG12 3P-0060-PNP	0301998	
KV BW08-SG08 3P-0030-PNP	0301495	
KV BW08-SG08 3P-0100-PNP	0301496	
KV BW08-SG08 3P-0200-PNP	0301497	●
KV BW12-SG12 3P-0030-PNP	0301595	
KV BW12-SG12 3P-0100-PNP	0301596	
KV BW12-SG12 3P-0200-PNP	0301597	
Sensor distributor		
V2-M8	0301775	●
V4-M8	0301746	
V8-M8	0301751	

- ① Two sensors are required per unit for monitoring two positions. On option, extension cables and sensor distributors are available. Additional product variants of the sensor, and further information and technical data can be found in the catalog chapter sensor system.



Gripping force

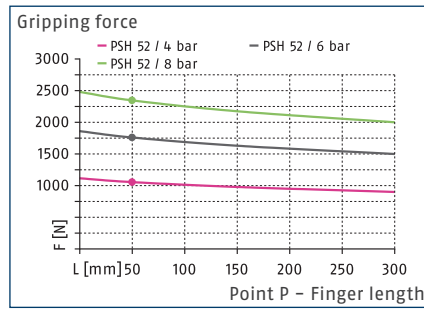

Dimensions and maximum loads

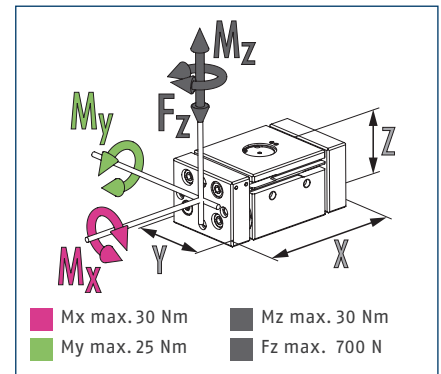

ⓘ The indicated moments and forces are static values, apply for each base jaw and may appear simultaneously. Loads may additionally occur to the moment produced by the gripping force itself.

Technical data

Description		PSH 52-1
ID		0302152
Stroke per jaw	[mm]	64
Closing/opening force	[N]	1760/1760
Weight	[kg]	8.05
Recommended workpiece weight	[kg]	8.8
Cylinder volume per double stroke	[cm ³]	504
Min./nom./max. operating pressure	[bar]	3/6/8
Closing/opening time	[s]	0.4/0.4
Max. permissible finger length	[mm]	300
Max. permissible weight per finger	[kg]	3.5
IP protection class		67
Min./max. ambient temperature	[°C]	5/90
Repeat accuracy	[mm]	0.05
Dimensions X x Y x Z	[mm]	296 x 119 x 92
Options and their characteristics		
High-temperature version		39302152
Min./max. ambient temperature	[°C]	5/130

ⓘ It may take a few 100 gripping cycles until the full gripping force (as indicated in the data table) will be available.

Main view PSH 52-1

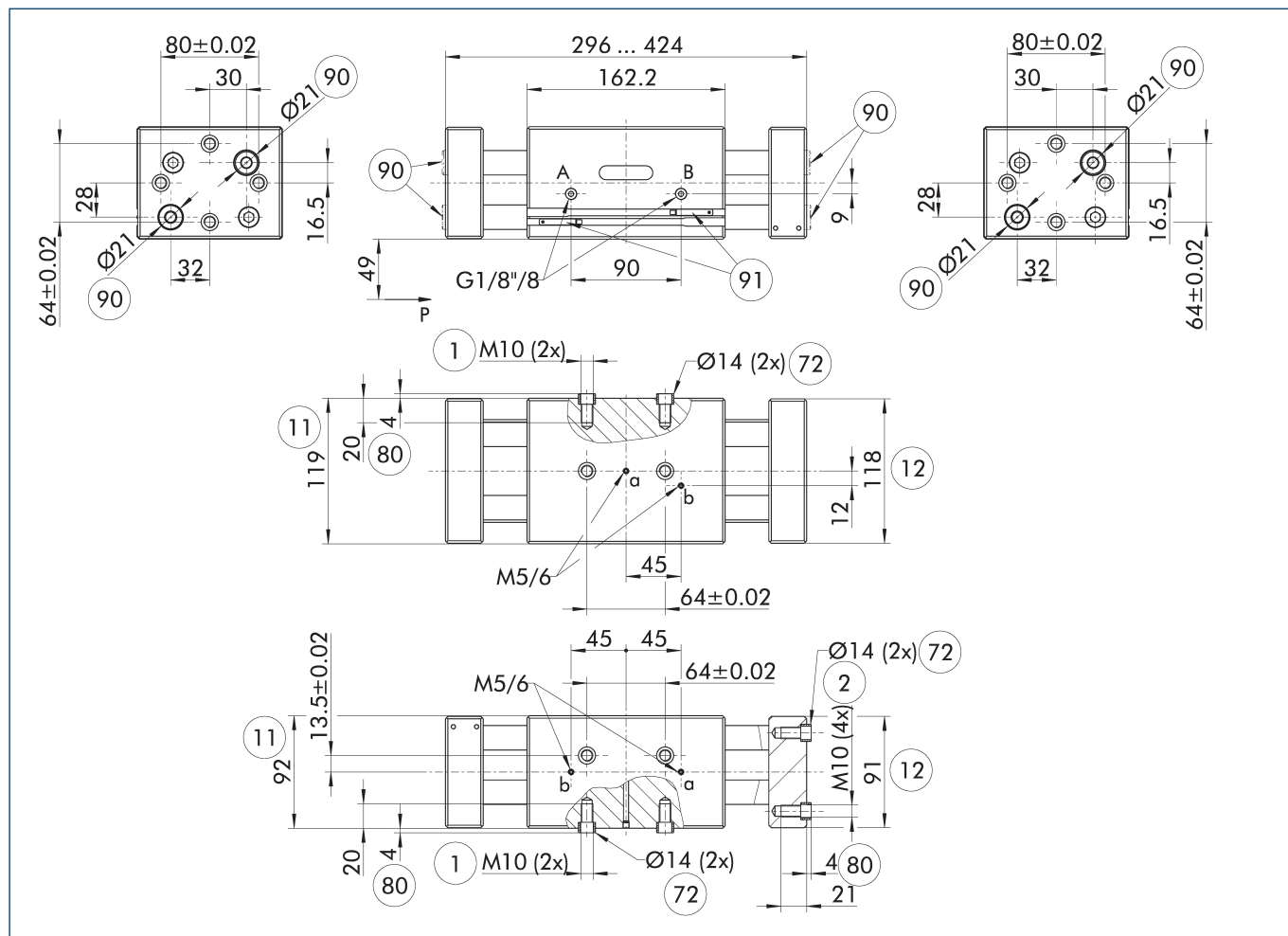

The drawing shows the gripper in the basic version with closed jaws, without dimensional consideration of the options described below.

① The SDV-P pressure maintenance valve can be used as a gripping force maintenance device (see catalog section on accessories).

- A, a Main / direct connection, gripper opening
- B, b Main / direct connection, gripper closing
- ① Gripper connection
- ② Finger connection
- ⑪ Housing

- ⑫ Jaw
- ⑦② Fit for centering sleeves
- ⑧① Depth of the centering sleeve hole in the counter part
- ⑨① Cut-out for the finger design
- ⑨① MMS 30... sensor

PSH 52

Long-stroke gripper

Maximum permitted finger projection

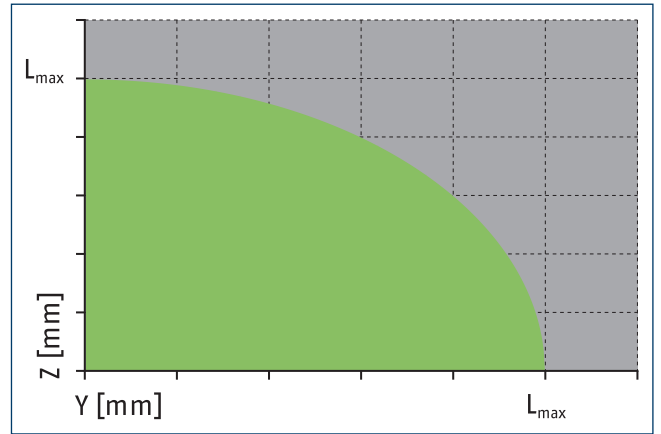
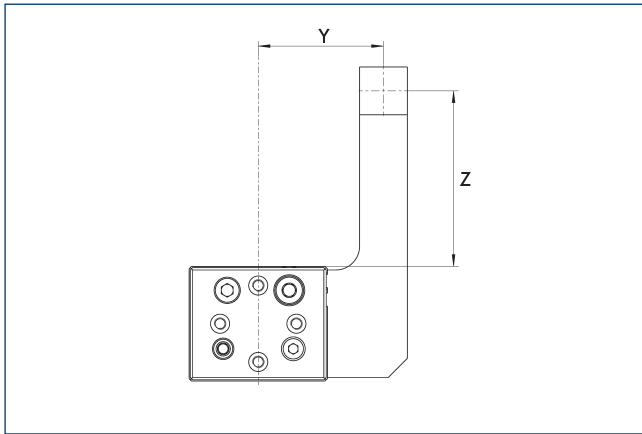

■ Permitted range ■ Inadmissible range

L^{max} is equivalent to the maximum permitted finger length, see the technical data table.

Hose-free direct connection M5

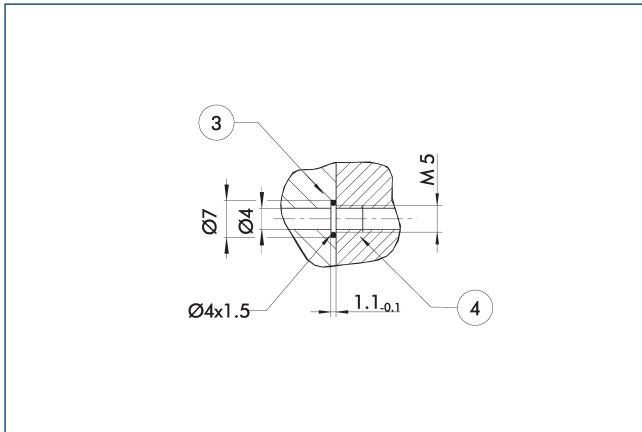

③ Adapter

④ Grippers

The direct connection is used for supplying compressed air without hoses. Instead, the pressure medium is fed through bore-holes in the mounting plate.

Finger design

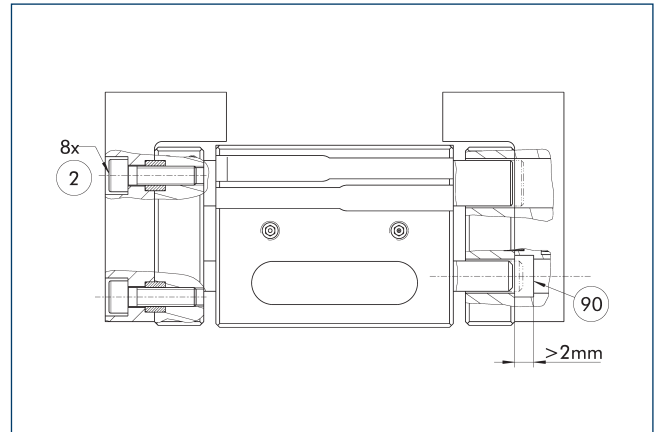

② Finger connection

⑨⁰ Recess

When closing the gripper completely, the piston rod can project beyond the end. If the entire closing stroke is required in the application, the recess is essential.

SDV-P pressure maintenance valve

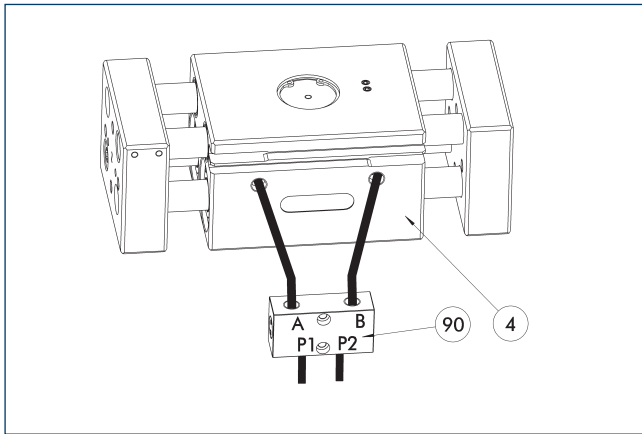

- ④ Grippers
- ⑨⑩ SDV-P pressure maintenance valve

The SDV-P pressure maintenance valve ensures in emergency STOP situations that the pressure in the piston chamber of pneumatic gripper, swivel, linear, and quick-change modules is temporarily maintained.

Description	ID	Recommended hose diameter [mm]
Pressure maintenance valve		
SDV-P 07	0403131	8
Pressure maintenance valve with air bleed screw		
SDV-P 07-E	0300121	8

① In order to achieve the specified closing and opening time for each gripper variant, the recommended hose diameter must be used. The direct allocation of the respective variant of the gripper for the respective SDV-P can be found at schunk.com.

Intermediate jaw interface

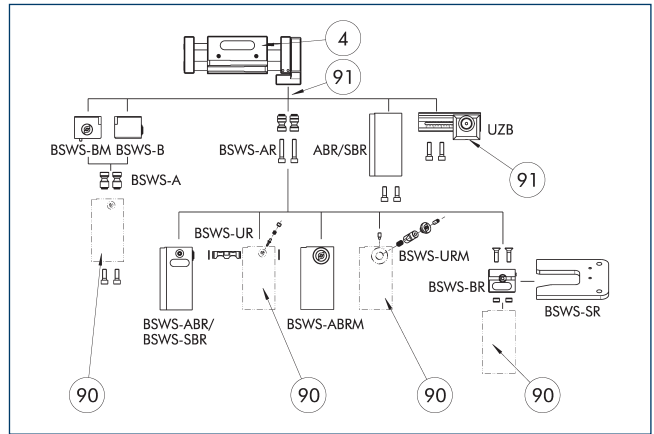

- ④ Grippers
- ⑨⑩ Uniform screw connection pattern
- ⑨⑪ Customized gripper fingers

By using the intermediate jaw, you have the possibility of directly connecting a wide range of accessories directly. This includes jaw quick-change systems, finger blanks, and universal intermediate jaws.

ZBA PSH 52-160 intermediate jaw

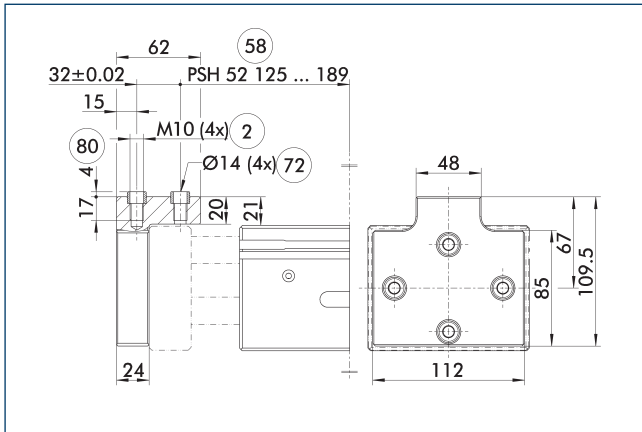

- ② Finger connection
- ⑤⑧ Distance from center of gripper
- ⑦② Fit for centering sleeves
- ⑧⑩ Depth of the centering sleeve hole in the counter part

Optionally intermediate jaws can be used, enabling direct connection and alignment of top jaws and various standard accessories in Z-direction.

Description	ID	Material	Finger interface	Scope of delivery
Intermediate jaw				
ZBA-PSH-52-160	0300228	Aluminum	PGN-plus 160	2

PSH 52

Long-stroke gripper

Inductive proximity switches

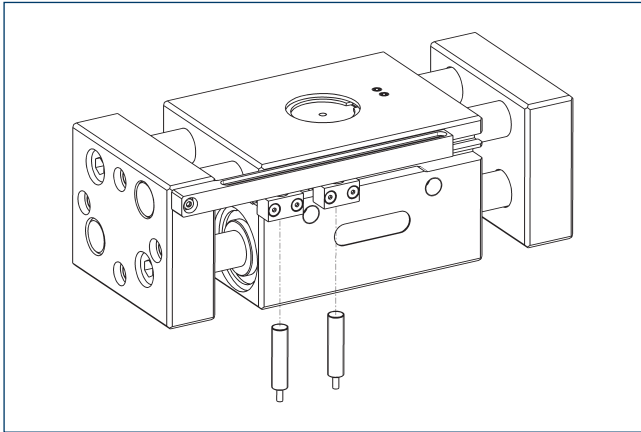

End position monitoring can be mounted with an attachment kit.

Description	ID	Often combined
Attachment kit for proximity switch		
HG-PSH 52	0300759	
Inductive proximity switch		
IN 80-S-M12	0301578	
IN 80-S-M8	0301478	●
IN-C 80-S-M8-PNP	0301475	
INK 80-S	0301550	
INK 80-SL	0301579	

① Two sensors (closer/S) are required for each unit and extension cables are available as an option. This attachment kit needs to be ordered optionally as an accessory. For sensor cables, note the minimum permissible bending radii. These are generally 35 mm.

Electronic magnetic switch MMS

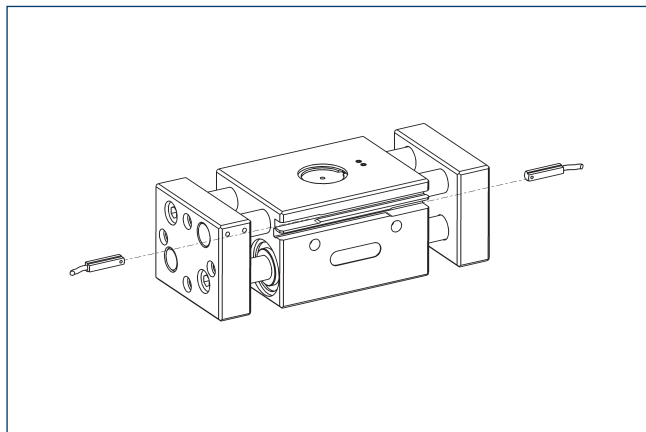

End position monitoring for mounting in the T-slot

Description	ID	Often combined
Electronic magnetic switch		
MMS 30-S-M12-PNP	0301571	
MMS 30-S-M8-PNP	0301471	●
MMSK 30-S-PNP	0301563	
Connection cables		
KA BG08-L 3P-0300-PNP	0301622	●
KA BG08-L 3P-0500-PNP	0301623	
KA BG12-L 3P-0500-PNP	30016369	
KA BW08-L 3P-0300-PNP	0301594	
KA BW08-L 3P-0500-PNP	0301502	
Clip for connector/socket		
CLI-M12	0301464	
CLI-M8	0301463	
Cable extension		
KV BG12-SG12 3P-0030-PNP	0301999	
KV BG12-SG12 3P-0060-PNP	0301998	
KV BW08-SG08 3P-0030-PNP	0301495	
KV BW08-SG08 3P-0100-PNP	0301496	
KV BW08-SG08 3P-0200-PNP	0301497	●
KV BW12-SG12 3P-0030-PNP	0301595	
KV BW12-SG12 3P-0100-PNP	0301596	
KV BW12-SG12 3P-0200-PNP	0301597	
Sensor distributor		
V2-M8	0301775	●
V4-M8	0301746	
V8-M8	0301751	

- ① Two sensors are required per unit for monitoring two positions. On option, extension cables and sensor distributors are available. Additional product variants of the sensor, and further information and technical data can be found in the catalog chapter sensor system.



SCHUNK GmbH & Co. KG
Spann- und Greiftechnik

Bahnhofstr. 106 - 134
D-74348 Lauffen/Neckar
Tel. +49-7133-103-0
Fax +49-7133-103-2399
info@de.schunk.com
schunk.com

Folgen Sie uns | *Follow us*

